

TRACKING GENERATOR COUNTER

8443A



HEWLETT  PACKARD

TRACKING GENERATOR/COUNTER 8443A

SERIAL NUMBERS PREFIXED: 955-, 964-

This manual applies directly to HP Model 8443A Tracking Generator/Counter having serial prefix numbers 955- and 964-.

OTHER PREFIXES

See Section VII, MANUAL CHANGES.

Copyright HEWLETT-PACKARD COMPANY 1970
1501 PAGE MILL ROAD, PALO ALTO, CALIFORNIA, U.S.A

08443-90009

Printed: JUNE 1970

HEWLETT  PACKARD

TABLE OF CONTENTS

Section	Page	Section	Page
I GENERAL INFORMATION	1-1	4-15. Specification 6, Resolution (Gate Time)	4-10
1-1. Introduction	1-1	4-16. Specification 7, Accuracy	4-10
1-5. Instruments Covered by Manual	1-1	4-17. Specification 8, Time Base Aging Rate	4-10
1-7. Description	1-1	4-18. Specification 9, Time Base Temperature Drift	4-12
1-15. Options	1-3	4-19. Specification 10, External Counter Input	4-18
1-16. Spectrum Analyzer RF Sections	1-3	4-20. Specification 11, External Time Base	4-14
1-17. Spectrum Analyzer IF Section	1-3	4-21. Specification 12, Time Base Output	4-14
1-18. Spectrum Analyzer Display Section	1-3	4-22. Specification 13, Digital Frequency Readout	4-14
1-19. Accessories Supplied	1-3	V ADJUSTMENTS	5-1
1-21. Accessories Not Supplied	1-3	5-1. Introduction	5-1
1-23. Warranty	1-3	5-3. Test Equipment	5-1
1-25. Test Equipment and Accessories Required	1-3	5-5. HP 98443-60011 Service Kit	5-1
II INSTALLATION	2-1	5-8. Factory Selected Components	5-1
2-1. Initial Inspection	2-1	5-10. Checks and Adjustment Arrangement	5-1
2-2. Mechanical Check	2-1	5-12. Checks and Adjustments	5-2
2-4. Electrical Check	2-1	5-13. Power Supplies Checks and Adjustments	5-2
2-6. Claims for Damage	2-1	5-14. First Converter (A13) Checks and Adjustments	5-3
2-9. Preparation for Use	2-1	5-15. 50 MHz IF Amplifier (A12) Checks and Adjustments	5-5
2-10. Power Requirements	2-1	5-16. Second Converter (A11) Checks and Adjustments	5-5
2-12. Power Cable	2-1	5-17. 200 MHz IF Amplifier (A10) Checks and Adjustments	5-5
2-14. Operating Environment	2-1	5-18. Third Converter (A9) Checks and Adjustments	5-6
2-16. Bench Operation	2-1	5-19. ALC/Video Amplifier Checks and Adjustments	5-7
2-18. Storage and Shipment	2-1	5-20. Reference Oscillator (A4) Checks and Adjustments	5-8
2-19. Original Packaging	2-1	VI REPLACEABLE PARTS	6-1
2-23. Other Packaging Materials	2-2	VII MANUAL CHANGES	7-1
III OPERATION	3-1	VIII SERVICE	8-1
3-1. Introduction	3-1	8-1. Introduction	8-1
3-4. Panel Features	3-1	8-3. Principles of Operation	8-1
3-6. Operating Instructions	3-1	8-5. Recommended Test Equipment	8-1
3-8. Operator's Checks	3-1	8-7. Troubleshooting	8-1
3-10. Special Features	3-3	8-11. Repair	8-1
3-13. Operator's Maintenance	3-3	8-20. General Service Hints	8-4
IV PERFORMANCE TESTS	4-1	8-23. Basic Service Information	8-8
4-1. Introduction	4-1	8-25. Logic Circuits and Symbols	8-8
4-3. Performance Tests	4-1		
4-9. Performance Tests	4-2		
4-10. Specification 1, Frequency Range	4-2		
4-11. Specification 2, Amplitude Range	4-3		
4-12. Specification 3, Amplitude Accuracy (Flatness)	4-6		
4-13. Specification 4, Output Impedance	4-8		
4-14. Specification 5, Measurement Range	4-9		

LIST OF ILLUSTRATIONS

Figure	Page	Figure	Page
1-1. Model 8443A Tracking Generator/Counter, Shown with Service Kit	1-0	8-21. A13, First Converter, Cover and Components	8-27
1-2. Instrument Identification	1-1	8-22. A12, 50 MHz Amplifier, Cover and Components	8-27
3-1. Tracking Generator/Counter Controls, Connectors and Indicators	3-2	8-23. First and Second Converter and IF Amplifier, Schematic Diagram	8-27
4-1. Frequency Range Test	4-2	8-24. A8, ALC Video Amplifier	8-29
4-2. Amplitude Range Test Setup	4-3	8-25. A9, Third Converter Assembly	8-29
4-3. Amplitude Accuracy Test	4-7	8-26. A10, Bandpass Filter Assembly	8-29
4-4. Output Impedance Test Setup	4-8	8-27. 200 MHz IF Amplifier, Third Converter, ALC/Video Amplifier and Attenuator, Schematic Diagram	8-29
4-5. Time Base Aging Rate Test	4-11	8-28. A14, Sense Amplifier Assembly, Components	8-31
4-6. Counter Input Test Setup	4-13	8-29. A15, Rectifier Assembly, Components	8-31
5-1. Power Supply Test Setup	5-2	8-30. Power Supplies and Regulators, Schematic Diagram	8-31
5-2. First Converter Test Setup	5-3	8-31. Counter Section Logic Diagram	8-33
5-3. 200 MHz IF Test Setup	5-5	8-32. A7, Marker Control Assembly, Cover and Components	8-35
5-4. Third Converter Test Setup	5-6	8-33. Marker Control Circuit, Schematic Diagram	8-35
5-5. ALC/Video Amplitider Test Setup	5-7	8-34. A5, Time Base Assembly, Cover and Components	8-37
5-6. Reference Oscillator Test Setup	5-9	8-35. Time Base Circuit, Schematic Diagram	8-37
8-1. Model 8443A with Circuit Board Extended for Maintenance	8-1	8-36. A6, High Frequency Decade Assembly, Cover and Components	8-39
8-2. Basic AND and OR Gates	8-8	8-37. High Frequency Decade Assembly, Schematic Diagram	8-39
8-3. Basic NAND and NOR Gates	8-9	8-38. A1, Low Frequency Counter Assembly, Components	8-41
8-4. Logic Comparison Diagrams	8-10	8-39. Low Frequency Counter Circuit, Schematic Diagram	8-41
8-5. Basic NOR Gate Flip-Flop	8-10	8-40. Overall Wiring Diagram, Including Chassis Mounted Parts	8-42
8-6. Triggered Flip-Flop	8-11	8-41. A16, Switch Assembly	8-42
8-7. RS Flip-Flop	8-12		
8-8. RST Flip-Flop	8-13		
8-9. Clocked JK Flip-Flop	8-13		
8-10. JK Master-Slave Flip-Flop (Typical)	8-14		
8-11. 16 Counter Binary Counter Chain	8-15		
8-12. 8421 BCD Decade Counter	8-16		
8-13. Blanking Decade Counter	8-17		
8-14. Buffer/Store	8-18		
8-15. Decoder	8-18		
8-16. Integrated Circuit Packaging	8-19		
8-17. Troubleshooting Tree	8-21		
8-18. Chassis Mounted Parts and Assembly Locations	8-23		
8-19. Overall Block Diagram	8-25		
8-20. A11 Second Converter, Cover and Components	8-26		

LIST OF TABLES

Table	Page	Table	Page
1-1. Model 8443A Specification	1-2	6-4. Parts Indexed by HP Part Number	6-27
1-2. Test Equipment and Accessories	1-3	6-5. Code List of Manufacturers	6-34
3-1. Fuse Information	3-3	8-1. Factory Selected Components	8-2
4-1. Performance Test Record	4-15	8-2. Schematic Diagram Notes	8-3
5-1. Performance Test Record	5-10	8-3. Etched Circuit Soldering Equipment	8-4
6-1. Part Numbers for Assembly Exchange Orders	6-1	8-4. Logic Symbology	8-5
6-2. Reference Designators and Abbreviations	6-2	8-5. JK Flip-Flop Truth Table	8-16
6-3. Parts Indexed by Reference Designation	6-3	8-6. 16 Count Binary Truth Table	8-16
		8-7. Assembly and Component Locations	8-23

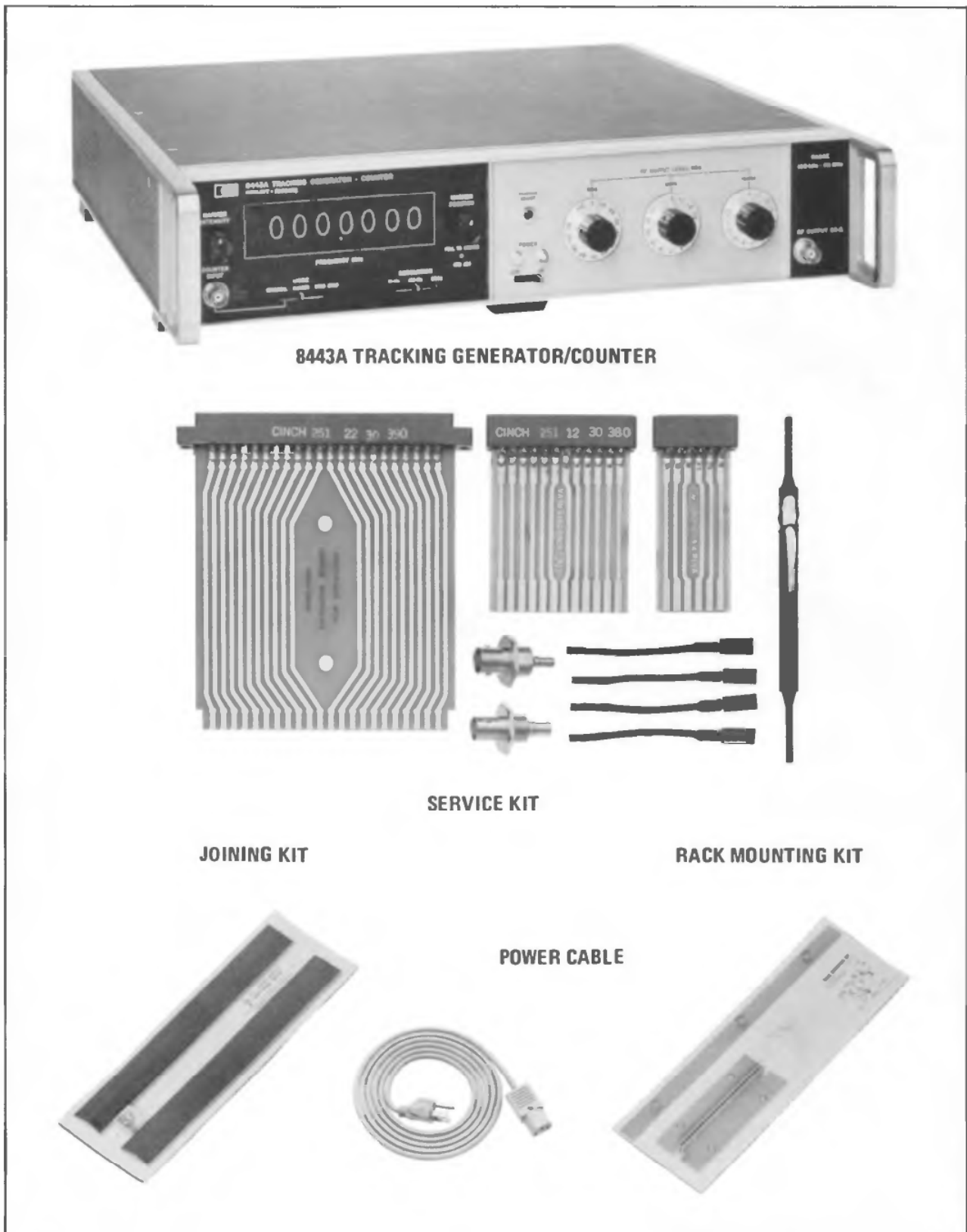

Figure 1-1. Model 8443A Tracking Generator/Counter, Shown with Service Kit (See Table 1-2)

SECTION I GENERAL INFORMATION

1-1. INTRODUCTION.

1-2. This manual contains all information required to install, operate, test, adjust and service the Hewlett-Packard Model 8443A Tracking Generator/Counter. This section covers instrument identification, description, options, accessories, specifications and other basic information.

1-3. Figure 1-1 shows the model 8443A with the supplied accessories and the Service Kit required for maintenance purposes.

1-4. The various sections in this manual provide information as follows:

a. SECTION II, INSTALLATION, provides information relative to incoming inspection, power requirements, mounting, packing and shipping, etc.

b. SECTION III, OPERATION, provides information relative to operating the instrument.

c. SECTION IV, PERFORMANCE TESTS, provides information required to ascertain that the instrument is performing in accordance with published specifications.

d. SECTION V, ADJUSTMENTS, provides information required to properly adjust and align the instrument after repairs are made.

e. SECTION VI, PARTS LISTS, provides ordering information for all replaceable parts and assemblies.

f. SECTION VII, MANUAL CHANGES, normally will contain no relevant information in the original issue of a manual. This section is reserved to provide back-dated and up-dated information in manual revisions or reprints.

g. SECTION VIII, SERVICE, includes all information required to service the instrument.

1-5. INSTRUMENTS COVERED BY MANUAL.

1-6. Hewlett-Packard instruments carry an eight digit serial number (see Figure 1-2) on the back panel. When the prefix on the serial number plate of your instrument is the same as one of the prefix numbers on the inside title page of this manual, the manual applies directly to the instru-

ment. When the instrument serial number prefix is not listed on the inside title page of initial issue, manual change sheets and manual up-dating information are provided. Later editions or revisions to the manual will contain the required change information in Section VII.

1-7. DESCRIPTION.

1-8. The Hewlett-Packard Model 8443A Tracking Generator/Counter was designed to be used in conjunction with the Hewlett-Packard 8553/8552 Spectrum Analyzer. The Tracking Generator provides a cw signal which tracks the frequency tuning of the spectrum analyzer.

1-9. As implied by the instrument name, the model 8443A also includes a counter section. The counter section may be used to count the output frequency of the tracking generator or the frequency of signals generated by external sources (up to better than 120 MHz). A rear panel connector provides BCD data output from the counter section for use in external equipment such as a recorder.

1-10. The time base for the model 8443A counter section is a stable oven-contained, crystal-controlled 1 MHz oscillator. Provisions are made to use an external 1 MHz source for the time base if a frequency standard is available. An output from the internal 1 MHz source is also available for use in external equipment if desired.

1-11. The model 8443A Counter Section may be operated in one of three modes. They are:

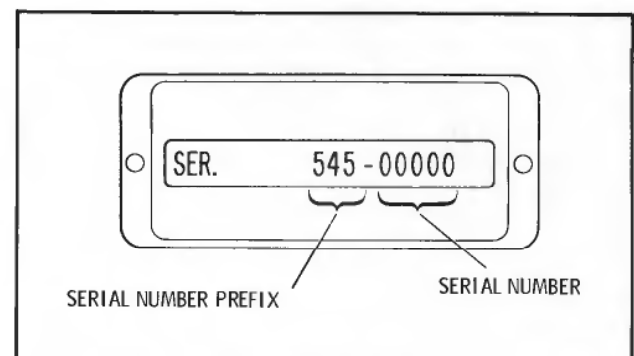

Figure 1-2. Instrument Identification

Table 1-1. Model 8443A Specification

SPECIFICATIONS	
Note	
Numbered specifications coincide with numbered performance tests in Section IV.	
TRACKING GENERATOR	
1. FREQUENCY RANGE: 100 kHz to 110 MHz. (Output frequency tracks the 8553/8552 Spectrum Analyzer tuning.)	6. RESOLUTION (gate time): 1 kHz (1 mS), 100 Hz (10 mS) and 10 Hz (100 mS).
2. AMPLITUDE RANGE: <-120 dBm to +10 dBm in 10 and 1 dB steps with a continuous 1.2 dB vernier.	7. ACCURACY: ±1 count ± time base accuracy.
3. AMPLITUDE ACCURACY (flatness): ±0.5 dB. Output attenuators 10 dB steps ±0.2 dB, 1 dB steps ±0.1 dB. Absolute: 0 dBm at 30 MHz ±0.3 dB.	8. TIME BASE AGING RATE: <3 x 10 ⁻⁹ per day. (0.3 Hz/day) after warmup.
4. OUTPUT IMPEDANCE: 50 ohms, AC coupled, reflection coefficient ≤0.09 (1.2 SWR); output <0 dBm.	9. TIME BASE TEMPERATURE DRIFT: <3 x 10 ⁻⁸ (3 Hz) variation, 0 to 55°C.
COUNTER	
MODES:	
MARKER: Counter reads frequency at marker position on the Spectrum Analyzer Display.	EXTERNAL INPUTS:
SCAN HOLD: Scan starts at left edge of display and stops at marker. Counter measures frequency continually.	10. COUNTER: 10 kHz to 120 MHz, 50 ohms, -10 dBm minimum, +25 dBm maximum.
EXTERNAL: Counter measures frequency of signal at counter input.	11. TIME BASE: 1 MHz, 50 ohm, 1 V rms minimum.
5. MEASUREMENT RANGE: 100 kHz to 110 MHz. Display; 7 digits with 1 digit overrange.	AUXILIARY OUTPUTS:
	12. TIME BASE: 1 MHz, 1 V rms nominal.
	13. DIGITAL FREQUENCY OUTPUT: 8, 4, 2, 1, code: positive logic.
	GENERAL:
	TEMPERATURE RANGE: Operation 0 to 55°C, storage, -40 to +75°C.
	POWER: 115 V or 230 V, 48–440 Hz, 75 watts. (When the instrument is in standby power consumption is 30 watts.)
	RFI: Meets or exceeds MIL-I-6181D.
	DIMENSIONS: 18-3/4 L x 16-3/4 W x 3-7/8 H.
	WEIGHT: 24 lbs, 5 oz. (11,02 kg)

a. **EXTERNAL.** For use in measuring frequency of external signals not related to the model 8443A or the Spectrum Analyzer.

b. **MARKER.** In this mode the scan ramp of the Spectrum Analyzer is stopped momentarily at a point determined by the model 8443A MARKER POSITION control. At the point where the scan is stopped a bright marker appears on the analyzer display CRT. Simultaneously, the frequency at which the scan is stopped is counted one time by the model 8443A counter. After the count is completed the analyzer scan continues to the limit set by the analyzer controls. The cycle is repeated each time the analyzer scan reaches the point determined by the model 8443A MARKER POSITION control.

c. **SCAN HOLD.** In this mode operational sequence is similar to the MARKER mode except

that when the scan is stopped it will not restart until the operator changes the mode of operation. The counter will count continually in the SCAN HOLD mode. The marker position may be controlled manually by the MARKER POSITION control to measure the frequency at any point on the CRT.

1-12. A three-position RESOLUTION control on the model 8443A provides counter readouts (in MHz) to accuracies of 10 Hz, 100 Hz and 1 kHz.

1-13. The output of the model 8443A is level (±0.5 dB) from 100 kHz to 110 MHz. The output level may be adjusted, by means of three front panel controls, to any level between +10 dBm and -123.2 dBm.

1-14. Complete specifications for the model 8443A are provided in Table 1-1.

1-15. OPTIONS.

1-16. Spectrum Analyzer RF Sections:

- a. HP model 8553B is completely compatible with the Model 8443A Tracking Generator/Counter.
- b. HP model 8553L requires a modification to provide compatibility with the model 8443A. Modification kit part number is 08553-6065. After modification the unit is designated as 8553L-TG-1.

1-17. Spectrum Analyzer IF Section:

- a. HP model 8552A IF sections bearing serial numbers 945-01889 and below must be modified to provide interface compatibility with the model 8443A. The required modification kit part number is HP 08552-6060. After modification the unit is designated as 8552A-TG-1.
- b. The model 8552B is completely compatible with the Model 8443A Tracking Generator/Counter.

1-18. Spectrum Analyzer Display Section.

- a. Display section models 140A, 140S, 141A and 141S all require HP modification kit number 00140-69504 to provide compatibility with the model 8443A.
- b. Display section models 140T and 141T are compatible with the model 8443A.

1-19. ACCESSORIES SUPPLIED.

- 1-20. The following accessories are provided with the model 8443A:
- a. An interconnecting cable for use between the Spectrum Analyzer and the Tracking Generator/Counter.
 - b. A power cord.
 - c. A rack mounting kit.
 - d. A joining bracket kit.

1-21. ACCESSORIES NOT SUPPLIED.

1-22. A Service Kit, HP part number 08443-60011 is recommended for maintenance purposes.

1-23. WARRANTY.

1-24. Certification and Warranty information for the model 8443A appears on the inside front cover of this manual.

1-25. TEST EQUIPMENT AND ACCESSORIES REQUIRED.

1-26. Table 1-2 lists test equipment and accessories recommended to service the model 8443A.

Table 1-2. Test Equipment and Accessories

Item	Minimum Specifications	Suggested Model
Digital Voltmeter	Voltage Accuracy: $\pm 0.2\%$ Range Selection: Manual or Automatic Voltage Range: 1 — 1000 Vdc full scale Input Impedance: 10 megohms Polarity: Automatic Indication	HP 3440A Digital Voltmeter with HP 3444A Plug-in
Oscilloscope	Frequency Range: dc to 50 MHz Time Base: 1 μ s/div to 10 ms/div Time Base Accuracy: $\pm 3\%$ Dual Channel, Alternate Operation Ac or dc Coupling External Sweep Mode Voltage Accuracy: $\pm 3\%$ Sensitivity: 0.005 V/div	HP 180A with HP 1804A Vertical Amplifier and HP 1821A Horizontal Amplifier HP 10004 10:1 Divider Probes (4)
Spectrum Analyzer	Frequency Range: 0 — 100 MHz Scan Width: 10 MHz	HP 8553/8552/141S Spectrum Analyzer

Table 1-2. Test Equipment and Accessories (Cont)

Item	Minimum Specifications	Suggested Models
VHF Signal Generator	Frequency Range: 40 – 455 MHz Frequency Accuracy: $\pm 1\%$ Output Amplitude: > -20 dBm Output Impedance: 50 ohms	HP 608E/F VHF Signal Generator
Frequency Counter	Frequency Range: 100 kHz – 300 MHz Accuracy: $\pm 0.001\%$ Sensitivity: 100 mVrms Readout Digits: 7 digits	HP 5245L Frequency Counter
Tunable RF Voltmeter	Bandwidth: 1 kHz Frequency Range: 1 – 1000 MHz Sensitivity: 10 mV – 1 Vrms Input Impedance: ≥ 0.1 megohms	HP 8405A Vector Voltmeter
Three-Port Mixer	Frequency Range: 0.2 – 500 MHz Impedance: 50 ohms Connectors: Female BNC on all ports Input Power: 5 mW nominal	HP 10514A Mixer (2)
Power Supply	Output Voltage: Variable, 0 – 30 Vdc Output Current: 0 – 400 mA Meter Resolution: < 5 mV	HP 6217A Power Supply
Spectrum Analyzer	0 – 1250 mHz	HP 8554/8552/140 Spectrum Analyzer
Digital to Analog Converter/Recorder	Accuracy: 5% of full scale Command Pulse: ± 20 μ sec or greater, 6 to 20 volts Recorder: Response time $< 1/2$ second or less Accuracy: Better than 0.2% full scale.	HP 581A Option 01 with HP 680A
Amplifier	Frequency Range: dc to 1 MHz Accuracy: $\pm 0.3\%$ from dc to 10 kHz Distortion: $< 0.01\%$ below 1 kHz	HP 467A
Quartz Oscillator	Output Frequencies: 5 MHz, 1 MHz, 100 kHz Stability: $< 5 \times 10^{-10}$ per day	HP 105B
Frequency Synthesizer	Output Frequency: 100 kHz to 500 MHz Digital Frequency Selection: 0.1 Hz through 100 MHz per step, 20 μ sec selection time.	HP 5101A/5110B
Attenuator	Range: 120 dB in 10 dB steps Accuracy: ± 0.5 dB	HP 355D
RF Amplifier	20 dB or 40 dB gain – 1 kHz to 150 MHz	HP 461A

Table 1-2. Test Equipment and Accessories (Cont)

Item	Minimum Specifications	Suggested Model
RF Crystal Detector	0.1 MHz to 1.2 GHz, 50 ohms	HP 8471A
Temperature Controlled Oven	Adjustable from 0° to +55° C	
Test Oscillator	10 Hz to 10 MHz, 3.16V max into 50 Ω	HP 651B
Digital Recorder	8-4-2-1 input positive logic Eight column printout	HP 5050B
AC Voltmeter	0.5V to 300V full scale Frequency Range: 20 Hz to 700 MHz	HP 400D/E/F/H
Service Kit	Contents: 12 Pin extender board (HP 5060-5915) 6 Pin extender board (HP 5060-5914) 22 Pin extender board (HP 5060-0630) Coax Adapter, Selectro plug to BNC jack (HP 1250-1236) Coax Adapter, Selectro jack to BNC jack (HP 1250-1237) Oscilloscope Probe Adapters (4 each) (HP 10036-63202) Alignment Screwdriver (HP 8710-1010)	HP 08443-60011 Service Kit
Variable Voltage Transformer	Range: 102 - 127 Vac Voltmeter Range: 103 - 127 Vac \pm 1 volt	General Radio W5MT3A or Superior Electric UC1M
Cable Assembly (4)	Male BNC Connectors, 48 inches long	HP 10503A
Soldering Iron	47-1/2 watt	Ungar #776 with #4037 Heating Unit
X-Y Recorder	1, 10, 100 mV/in; 1 and 10 V/in continuous vernier between range	HP 7065B

SECTION II INSTALLATION

2-1. INITIAL INSPECTION.

2-2. Mechanical Check.

2-3. Check the shipping carton for evidence of damage immediately after receipt. If there is any visible damage to the carton, request the carrier's agent to be present when the instrument is unpacked. Inspect the model 8443A for physical damage such as bent or broken parts and dents or scratches. If damage is found refer to paragraph 2-6 for recommended claim procedures. If the model 8443A appears undamaged, perform the electrical check (see paragraph 2-4). The packaging material should be retained for possible future use.

2-4. Electrical Check.

2-5. The electrical performance check consists of following the procedures listed in paragraphs 4-10 to 4-22. These procedures allow the operator to determine that the instrument is, or is not, operating within the specifications listed in Table 1-1. The initial performance and accuracy of the instrument are certified as stated on the inside front cover of this manual. If the model 8443A does not operate as specified, refer to paragraph 2-6 for the recommended claim procedure.

2-6. CLAIMS FOR DAMAGE.

2-7. If physical damage is found when the instrument is unpacked notify the carrier and the nearest Hewlett-Packard Sales/Service Office immediately. The Sales/Service Office will arrange for repair or replacement without waiting for a claim to be settled with the carrier.

2-8. The warranty statement for the model 8443A is on the inside front cover of this manual. Contact the nearest Sales/Service Office for information about warranty claims.

2-9. PREPARATION FOR USE.

CAUTION

Before applying power check the rear panel slide switch for proper position (115 or 230 volts).

2-10. Power Requirements.

2-11. The model 8443A Tracking Generator/Counter may be operated on 115 or 230 volts ac

$\pm 10\%$ at 48 to 440 cycles, single phase. Power required is 75 watts. The 115/230 volt slide switch on the rear of the instrument must be in the correct position to avoid damage to the instrument. When shipped, the instrument is set for 115 volt ac operation.

2-12. Power Cable.

2-13. To protect operating personnel, the National Electrical Manufacturers Association (NEMA) recommends that the instrument panel and cabinet be grounded. This instrument is equipped with a detachable three-conductor power cable which, when plugged into an appropriate receptacle, grounds the instrument. The offset pin on the power cable three-prong connector is the ground connection. When using a three-prong to two-prong adapter the ground lead on the adapter should be grounded to retain the safety feature.

2-14. Operating Environment.

2-15. The model 8443A does not require forced air cooling when operating at temperatures from 0 to 55°C (32 to 131°F). Normal air circulation will maintain a reasonable temperature within the instrument.

2-16. Bench Operation.

2-17. The model 8443A cabinet has plastic feet and a foldaway tilt stand for convenience in bench operation. The tilt stand permits inclining the instrument for ease in viewing the frequency readout. The plastic feet are shaped to provide clearance for air circulation and to make modular cabinet width instruments self-aligning when stacked. The instrument may also be rack mounted. A joining bracket kit is provided to assure a common ground between the model 8443A and the Spectrum Analyzer.

2-18. STORAGE AND SHIPMENT.

2-19. Original Packaging.

2-20. The same containers and materials used in factory packaging can be obtained through the Hewlett-Packard Sales/Service Offices listed at the rear of this manual.

2-21. If the model 8443A is being returned to Hewlett-Packard for servicing attach a tag indicating the type of service required, return address,

model number and full serial number. Also mark the container FRAGILE to assure careful handling.

2-22. In any correspondence refer to the instrument by model number and full serial number.

2-23. Other Packaging Materials.

2-24. The following general instructions should be used for repackaging with commercially available materials.

a. Wrap the instrument in heavy paper or plastic. (If shipping to a Hewlett-Packard Service Office or center, attach a tag indicating the type

of service required, return address, model number and full serial number.)

b. Use a strong shipping container. A double-wall carton made of 350 pound test material is adequate.

c. Use enough shock-absorbing material (three to four inch layer) around all sides of the instrument to provide firm cushion and prevent movement inside the container. Protect the control panel with cardboard.

d. Seal the shipping container securely.

e. Mark the shipping container FRAGILE to assure careful handling.

SECTION III OPERATION

3-1. INTRODUCTION.

3-2. This section provides operating instructions for the HP Model 8443A Tracking Generator/Counter.

3-3. Operating instructions for the HP Model 8553/8552 Spectrum Analyzer, which must be interconnected with the model 8443A, are not included in this manual except as required in initial setup and operation. The operator should be thoroughly familiar with operation of the Spectrum Analyzer or have the appropriate manual on hand.

3-4. PANEL FEATURES.

3-5. Front and rear panel controls, indicators and connectors of the model 8443A are identified in Figure 3-1.

3-6. OPERATING INSTRUCTIONS.

3-7. In view of the simplicity of operation of the model 8443A, the Operator's Checks provide adequate information to assure proper operation of the instrument. However, the operator should experiment with the instrument in order to become more familiar with its operation. It should be noted that the output of any device (within the frequency and amplitude range of the analyzer) may be connected to the analyzer RF INPUT and the frequency at any point of the response counted by the model 8443A. The input to the device under test may be provided by an external signal generator, or by the output of the Tracking Generator itself.

3-8. OPERATOR'S CHECKS.

3-9. During checkout at the factory, the Tracking Generator/Counter is adjusted for proper operation. Only minor adjustment of front panel controls should be required upon receipt of the instrument. The following procedures verify proper operation of the model 8443A:

a. Set the slide switch on the rear panel of the model 8443A to be compatible with the available line voltage.

b. Plug into power outlet; use ground pin adapter for electrical systems having no ground wire. (Blue STBY light illuminates.)

NOTE

The instrument should remain connected to the power source in STBY mode when not in use. This will maintain constant temperature in the crystal oscillator oven.

c. Interconnect the Spectrum Analyzer and the Tracking Generator/Counter as shown in Figure 3-1.

d. Set POWER switch to ON; observe that the white ON lamp lights.

e. Apply power to the Spectrum Analyzer and adjust the display section for a clear baseline trace.

f. Set the Spectrum Analyzer controls as follows:

FREQUENCY	50 MHz
BANDWIDTH	300 kHz
SCAN WIDTH	PER DIVISION
SCAN WIDTH	
PER DIVISION	10 MHz
INPUT ATTENUATION	10 dB
BASE LINE CLIPPER	CCW
SCAN TIME	
PER DIVISION	1 MILLISECOND
LOG REF LEVEL	0 dBm
LOG/LINEAR	LOG
VIDEO FILTER	OFF
SCAN MODE	INT
SCAN TRIGGER	AUTO

g. Set the 8443A MODE SWITCH to MARKER, the RESOLUTION switch to 100 Hz and RF OUTPUT LEVEL controls to 0 dBm.

h. Connect the model 8443A RF OUTPUT to the 8553 RF INPUT. Note that the analyzer CRT baseline rises to the top graticule line.

i. Adjust the model 8443A MARKER INTENSITY control for the desired marker intensity. If the marker is not present adjust the MARKER POSITION control; the marker probably is positioned off the display.

NOTE

This will occur only if the instrument is improperly adjusted. Refer to step p of these procedures and adjust the CTR ADJ. If trouble persists refer to paragraph 3-15 and adjust A7R11 on the A7 Marker Control board.

j. Rotate the MARKER POSITION control to various points and note that the counter displays the frequency at the marker position on the CRT.

k. Center the marker on the center vertical graticule of the analyzer CRT. Rotate the analyzer FREQUENCY control through its range. Note that the counter displays the frequency to which the analyzer is tuned.

l. Rotate the model 8443A RF OUTPUT LEVEL controls and note that the analyzer CRT display changes in steps indicated by the knob positions. (At lower output levels it will be necessary to rotate the analyzer LOG REF LEVEL control to keep the signal in the analyzer amplitude range.)

m. Operate the analyzer in a narrow scan width, stabilized mode (20 kHz/Div) or less. Place the model 8443A RESOLUTION switch first in the 10 Hz position and then in the 1 kHz position. Note that the frequency readout is first to 10 Hz resolution and then to 1 kHz resolution.

n. Place the model 8443A MODE switch in the SCAN HOLD position. Note that the analyzer scan is stopped at the marker and the counter continually counts the frequency at which the scan is stopped. In the SCAN HOLD mode the point at which the scan is stopped may be positioned at any point on the CRT, while the scan is stopped, by the MARKER POSITION control.

o. Place the model 8443A MODE switch in the EXTERNAL position. Apply a signal (at least -10 dBm but not more than +25 dBm, 10 kHz to 120 MHz) from a frequency source to the COUNTER INPUT. If an external signal source is not readily available, the tracking generator RF OUTPUT may be coupled to the COUNTER INPUT. Operate analyzer in ZERO scan mode. The counter will provide a readout of the input signal frequency. Note that the marker does not appear in this mode of operation.

p. With the model 8443A in the MARKER mode, pull the MARKER POSITION control knob away from the panel. The marker should appear on the center vertical graticule line of the analyzer CRT. Adjust the CTR ADJ screwdriver adjustment on the 8443A front panel to verify that it controls the marker position. Return marker to center graticule position with the CTR ADJ control and push the MARKER POSITION control knob back in place.

q. Connect the model 8443A RF OUTPUT to the analyzer RF INPUT.

r. Place the MODE switch in the MARKER position and the RESOLUTION switch in the 1 kHz position. Tune the analyzer to a frequency

below 10 MHz and note that three of the numerical readouts to the left of the decimal point display a zero. Place the switch on the rear panel to BLANKED and note that all zeros to the left of the first significant digit are blanked. Set the model 8443A RF OUTPUT LEVEL to -30 dBm. Set the 8553 to ZERO scan at the narrowest bandwidth. Set the 8552 to the LINEAR mode at 1 mV/Div. Adjust the 8443A TRACKING ADJUST for maximum vertical deflection on the analyzer CRT. This assures that the 3 MHz oscillator in the 8443A first converter is tracking the 3 MHz IF frequency of the 8552.

3-10. SPECIAL FEATURES.

3-11. The output of the internal 1 MHz time base reference oscillator is available for use in external equipment at J4 on the rear of the instrument.

3-12. An external time base reference signal may be applied to J3 on the rear panel of the model 8443A. When an external reference signal is used, the switch on the top of the A5 time base assembly must be placed in the EXT position.

3-13. OPERATOR'S MAINTENANCE.

3-14. Operator's maintenance on the model 8443A is limited to fuse replacement, adjustment of the controls indicated in the checkout procedure and adjustment of A7R11 on the A7 marker control board.

3-15. Adjustment of A7R11 on the marker control board should be made only if the condition described in step i of paragraph 3-9 exists. To properly adjust A7R11 first turn the MARKER POSITION control fully clockwise. Adjust the CTR ADJ control so that the marker appears approximately one minor division from the far right CRT graticule line. Turn the MARKER POSITION control fully counterclockwise. The marker should be two minor divisions or less from the far left graticule line. Now pull the MARKER POSITION control away from the panel and adjust A7R11 to center the marker on the center CRT graticule line.

3-16. Fuse replacement information is provided in Table 3-1.

Table 3-1. Fuse Information

Designation	Purpose	Rating
F1	Line Fuse	2 amperes
A15F1	+175 Volt Supply	0.25 ampere
A15F2	+24 Volt Supply	1 ampere
A15F3	+5.8 Volt Supply	2 amperes
A15F4	+20 Volt Supply	1 ampere
A15F5	-12 Volt Supply	1 ampere

SECTION IV PERFORMANCE TESTS

4-1. INTRODUCTION.

4-2. This section provides instructions for performance testing the model 8443A Tracking Generator/Counter.

4-3. Performance Tests.

4-4. Purpose. The performance test procedures are used to check instrument performance for incoming inspection and periodic evaluation. The tests are designed to verify published specifications. Tests are numbered in the same sequence as the specifications in Table 1-1.

4-5. Each test applies directly to a listed specification. Next a description of the test and any special instructions are listed. Each test that requires test equipment has a test setup drawing

and a list of required equipment. Step 1 of each test lists control settings for that test. Each test procedure provides spaces for test data which are duplicated in the Performance Test Card, Table 4-1, at the end of this section.

4-6. All tests are made with the model 8443A interconnected with a HP 8553/8852/140 Spectrum Analyzer which is known to be functioning properly.

4-7. Test Equipment Required. The test instruments required for performance testing are listed in Table 1-2 and in the individual tests. Test instruments other than those listed may be used providing their performance equals or exceeds the critical specifications listed in Table 1-2.

4-8. Front Panel Checks and Adjustments. Refer to paragraph 3-8 Operator's Checks.

4-9. PERFORMANCE TESTS.

4-10. Specification 1, Frequency Range.

SPECIFICATION:

100 kHz to 110 MHz. (Output frequency tracks the 8553/8552 Spectrum Analyzer tuning.)

DESCRIPTION:

The frequency range is checked by applying signals to the Spectrum Analyzer, centering these signals on the CRT and counting the signal frequency with the model 8443A.

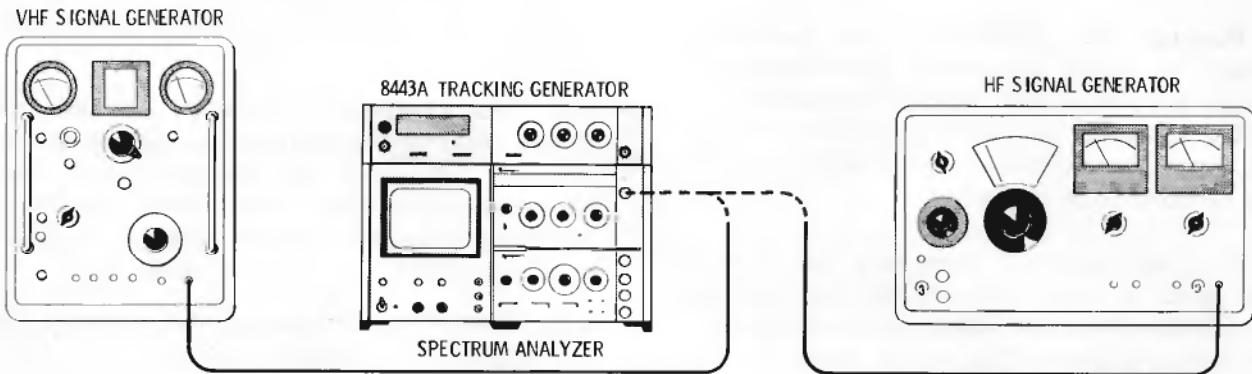

Figure 4-1. Frequency Range Test

EQUIPMENT:

HF Signal Generator

VHF Signal Generator

PROCEDURE:

1. Connect the equipment as shown in Figure 4-1 and set the controls as follows:

TRACKING GENERATOR/COUNTER:

MODE	MARKER	MARKER POSITION	Knob pulled out
RESOLUTION	10 Hz	MARKER INTENSITY	Mid-range

SPECTRUM ANALYZER:

DISPLAY	SCAN WIDTH PER DIVISION	5 kHz
SECTION	BANDWIDTH	1 kHz
Clearly defined trace	SCAN TIME PER DIVISION	20 mSec
INPUT ATTENUATION	LOG REF LEVEL	0 dBm
10 dB		
SCAN WIDTH		
PER DIVISION		

HF SIGNAL GENERATOR:

FREQUENCY	100 kHz	MODULATION SELECTOR	CW
ATTENUATOR	-50 dBm		

VHF SIGNAL GENERATOR:

FREQUENCY	110 MHz	MODULATION	CW
OUTPUT	-50 dBm		

PERFORMANCE TESTS (Cont.)

4-10. Specification 1, Frequency Range (Cont.)

2. With the HF Signal Generator output connected to the analyzer RF INPUT, tune the analyzer FREQUENCY to 100 kHz. The model 8443A counter, which is reading the output of the tracking generator, should provide a readout of 100 kHz.

100 kHz _____

3. With the VHF Signal Generator output connected to the analyzer RF INPUT, tune the analyzer FREQUENCY to 110 MHz. The model 8443 counter should provide a readout of 110 MHz.

110 MHz _____

4. Any other frequency or frequencies of special interest within the range of 110 kHz to 110 MHz may be displayed in the same manner.

4-11. Specification 2, Amplitude Range.

SPECIFICATION:

<-120 dBm to +10 dBm in 10 and 1 dB steps with a continuous 1.2 dB vernier.

DESCRIPTION:

The output of the video amplifier in the model 8443A is a constant +10 dBm signal. Two step attenuators are provided to enable the operator to control the output amplitude in 10 dB and 1 dB steps. In addition, a 1.2 dB vernier provides continuous attenuation of its range. This test demonstrates the accuracy of the attenuators.

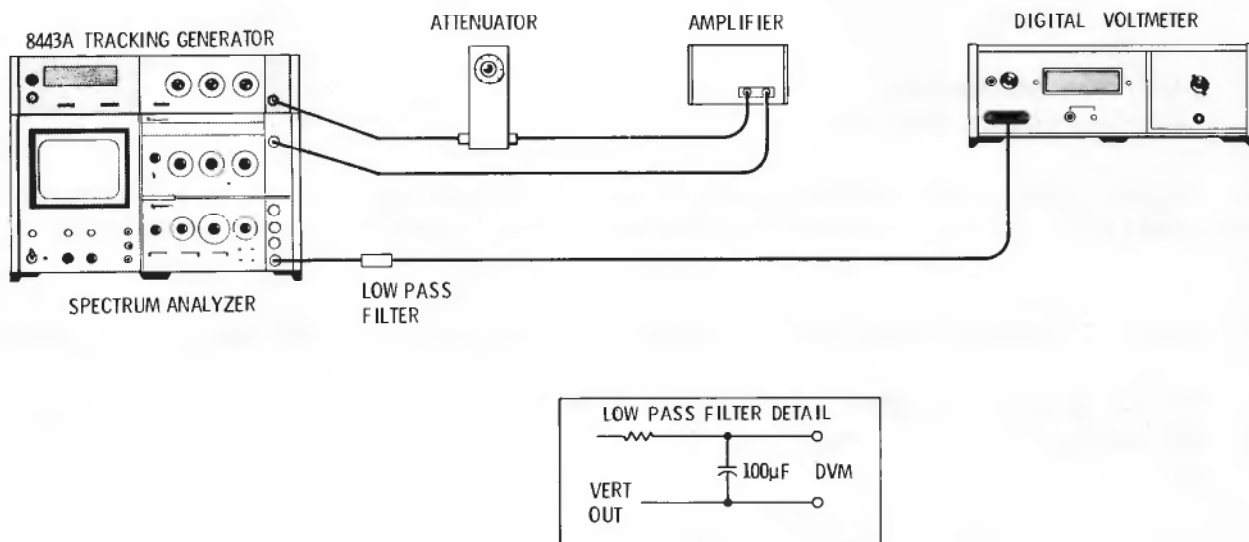

Figure 4-2. Amplitude Range Test Setup

PERFORMANCE TESTS (Cont.)

4-11. Specification 2, Amplitude Range (Cont.)

EQUIPMENT:

120 dB Calibrated Attenuator (10 dB Steps)
12 dB Calibrated Attenuator (1 dB Steps)

RF Amplifier (40 dB gain, 30 MHz)
Digital Voltmeter

PROCEDURE:

1. Connect the 120 dB attenuator to the model 8443A RF OUTPUT using a BNC to BNC adapter (do not use a cable). Set the controls as follows:

TRACKING GENERATOR/COUNTER:

MODE MARKER
RESOLUTION 1 kHz

MARKER POSITION Any

ATTENUATORS:

TENS +10
UNITS 0

TENTHS 0

SPECTRUM ANALYZER:

FREQUENCY 30 MHz
BANDWIDTH 50 Hz
SCAN WIDTH ZERO
SCAN WIDTH PER DIVISION . . . Any
INPUT ATTENUATION 0

SCAN TIME PER
DIVISION 1 MILLISECOND
LOG REF LEVEL -40 dBm
LOG REF LEVEL VERNIER 0
LOG/LINEAR LOG

RF AMPLIFIER:

Power ON 40 dB gain

120 dB CALIBRATED ATTENUATOR

Set for 120 dB attenuation

DIGITAL VOLTMETER:

AUTORANGE or 1000 Millivolts

2. Use very short double shielded cables to connect the equipment as shown in Figure 4-2. A low-pass filter (100 microfarad) is required between the vertical output of the 8552 and the digital voltmeter.
3. Adjust the analyzer FREQUENCY to obtain a 30 MHz readout on the model 8443A counter.
4. Use the model 8443A TENTHS control to set the digital voltmeter reading to 300 mV. (Allow time for the low-pass filter to stabilize.)

PERFORMANCE TESTS (Cont.)

4-11. Specification 2, Amplitude Range (Cont.)

5. Set the model 8443A TENS control to 0 and the calibrated attenuator to 110 dB.

0 dBm DVM reading: 298 mV _____ 302 mV

6. If necessary, reset the model 8443A TENTHS control to obtain a reading of 300 mV on the digital voltmeter. Change the model 8443A TENS control to -10 and the calibrated attenuator to 100 dB.

-10 dBm DVM reading: 298 mV _____ 302 mV

7. Check the remaining model 8443A attenuator steps by adding 10 dB steps with the TENS attenuator, while decreasing the calibrated attenuator in 10 dB steps (the sum of the two attenuators should always total 110 dB). The digital voltmeter should be reset to 300 mV prior to each step if necessary.

-20 dBm DVM reading: 298 mV _____ 302 mV

-30 dBm DVM reading: 298 mV _____ 302 mV

-40 dBm DVM reading: 298 mV _____ 302 mV

-50 dBm DVM reading: 298 mV _____ 302 mV

-60 dBm DVM reading: 298 mV _____ 302 mV

-70 dBm DVM reading: 298 mV _____ 302 mV

-80 dBm DVM reading: 298 mV _____ 302 mV

-90 dBm DVM reading: 298 mV _____ 302 mV

-100 dBm DVM reading: 298 mV _____ 302 mV

-110 dBm DVM reading: 298 mV _____ 302 mV

8. Remove the RF Amplifier and the 120 dB calibrated attenuator from the test setup. Connect the 12 dB calibrated attenuator between the model 8443A RF OUTPUT and the analyzer RF INPUT. Set the model 8443A TENS attenuator to -50 dBm and the analyzer LOG REF LEVEL to -10 dBm. Set the calibrated 12 dB attenuator to 12 dB. Adjust the model 8443A TENTHS control to obtain a reading of 300 mV on the digital voltmeter.

9. Set the model 8443A UNITS attenuator to -1 and the 12 dB calibrated attenuator to 11. The digital voltmeter should indicate 300 mV ±1 mV

-1 dBm DVM reading: 299 mV _____ 301 mV

PERFORMANCE TESTS (Cont.)

4-11. Specification 2, Amplitude Range (Cont.)

10. Check the remaining UNITS steps by increasing the UNITS attenuation in 1 dB steps while decreasing the 12 dB calibrated attenuator by 1 dB steps. (The sum of the two attenuators should always total 12 dB.) The digital voltmeter should be reset to 300 mV prior to each step if necessary.

-2 dBm DVM reading:	299 mV _____	301 mV
-3 dBm DVM reading:	299 mV _____	301 mV
-4 dBm DVM reading:	299 mV _____	301 mV
-5 dBm DVM reading:	299 mV _____	301 mV
-6 dBm DVM reading:	299 mV _____	301 mV
-7 dBm DVM reading:	299 mV _____	301 mV
-8 dBm DVM reading:	299 mV _____	301 mV
-9 dBm DVM reading:	299 mV _____	301 mV
-10 dBm DVM reading:	299 mV _____	301 mV
-11 dBm DVM reading:	299 mV _____	301 mV
-12 dBm DVM reading:	299 mV _____	301 mV

4-12. Specification 3, Amplitude Accuracy (Flatness)

SPECIFICATION:

±0.5 dB across entire range.

DESCRIPTION:

The Spectrum Analyzer is swept through its entire range and the output of the model 8443A is recorded on an X-Y Recorder.

EQUIPMENT:

X-Y Recorder

Crystal Detector

PROCEDURE:

1. Connect the equipment as shown in Figure 4-3 and set the controls as follows:

TRACKING GENERATOR/COUNTER:

MODE SCAN HOLD

RF LEVEL ATTENUATORS 0 dB

MARKER POSITION CCW

SPECTRUM ANALYZER:

SCAN WIDTH ZERO

SCAN MODE SINGLE

SCAN TIME 2 sec/Div

SCAN TRIGGER AUTO

PERFORMANCE TESTS (Cont.)

4-12. Specification 3, Amplitude Accuracy (Flatness) (Cont.)

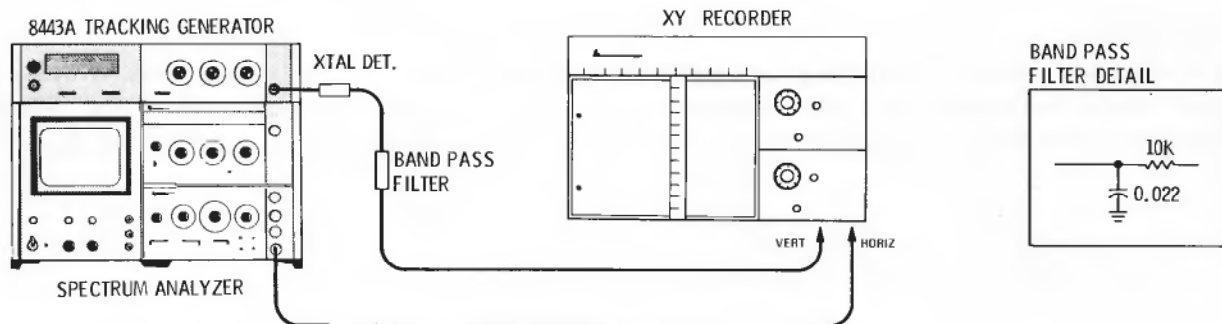

Figure 4-3. Amplitude Accuracy Test

X-Y RECORDER:

Vertical trace begins at left margin of recorder chart paper and ends at right margin synchronized to the beginning and end of the analyzer scan ramp.

Horizontal position of the stylus may be anywhere on the recorder chart paper which permits a 1 dB step without reaching top or bottom limits.

2. With all controls set as shown above, place the PEN switch on the recorder to the DOWN position, push the SINGLE scan button on the analyzer and turn the model 8443A MARKER POSITION control to the CW position. Be sure to place the recorder PEN switch in the UP position as soon as the scan stops. Return the model 8443A MARKER POSITION control to full CCW.

3. Turn the model 8443A ONES attenuator to 1 dB and repeat step 2. Return the ONES attenuator to 0 dB.

4. Set the analyzer to SCAN WIDTH PER DIVISION at 10 MHz, and tune the analyzer to approximately 50 MHz. Carefully tune the analyzer to indicate a 100 kHz readout on the model 8443A. Position the recorder stylus slightly below the top line drawn in steps 2 and 3. Place the PEN switch on the recorder in the down position, turn the model 8443A MARKER POSITION control to the 3 o'clock position and depress the SINGLE scan button on the analyzer. When the scan stops slowly turn the MARKER POSITION control until the model 8443A counter indicates 90 MHz. Place the recorder PEN switch in the UP position and return the stylus to the left margin of the recorder chart by pressing the analyzer SINGLE button.

5. Set the analyzer SCAN WIDTH PER DIVISION to 2 MHz and tune the analyzer FREQUENCY to a point where the model 8443A counter reads 90 MHz. The recorder stylus should be positioned at the same level as the 90 MHz point in test 4. Place the recorder PEN switch in the DOWN position and push the SINGLE button on the analyzer. When the recorder stylus reaches the right hand margin of the recorder chart place the PEN switch in the UP position. The entire trace (steps 4 and 5) should be between the two lines drawn in steps 2 and 3.

±0.5 dB _____

PERFORMANCE TESTS (Cont)

4-13. Specification 4, Output Impedance.

SPECIFICATION:

50 ohms, ac coupled, reflection coefficient ≤ 0.09 (1.2 SWR); output 0 dB.

DESCRIPTION:

The rf output from the Tracking Generator is measured with a RF Voltmeter; first with no load, then terminated in 50 ohms. The source resistance (R_s) of the Tracking Generator is then calculated and finally the SWR is determined by dividing Z_o by R_s (R_s by Z_o if Z_o is greater than R_s).

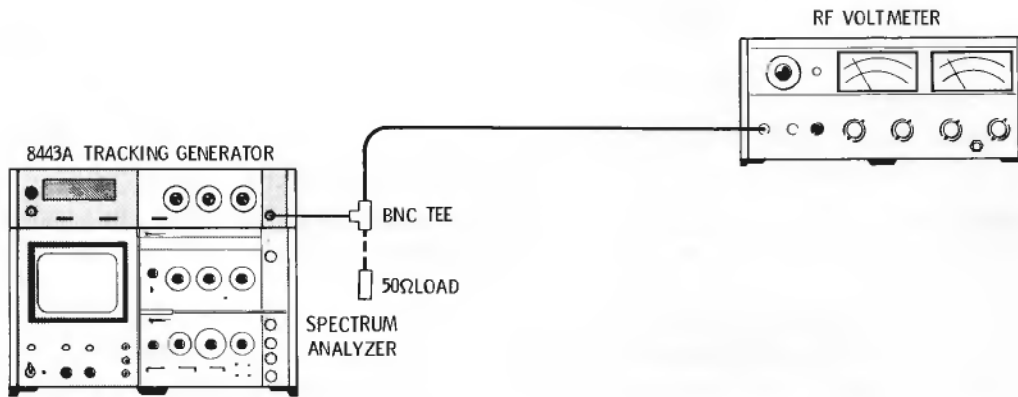

Figure 4-4. Output Impedance Test Setup

EQUIPMENT:

RF Vector Voltmeter
50 ohm dummy load

BNC Tee

PROCEDURE;

1. Connect the equipment as shown in Figure 4-4 and set the controls as follows:

TRACKING GENERATOR/COUNTER:

RF OUTPUT

LEVEL dBm . . . All controls set to 0
RESOLUTION Any

POWER ON
MODE SCAN HOLD

SPECTRUM ANALYZER

FREQUENCY 30 MHz
SCAN WIDTH PER DIVISION . . . 1 kHz

SCAN WIDTH ZERO
ALL OTHER CONTROLS . . Any setting

PERFORMANCE TESTS (Cont.)

4-13. Specification 4, Output Impedance (Cont.)

RF Vector Voltmeter		
CHANNEL	A	RANGE 1000 mV
FREQ RANGE — MHz	30 MHz (APC locked)	PHASE CONTROLS Not used

2. Measure the rf output of the Tracking Generator with the RF Vector Voltmeter. Record the reading:

$$V_{OC} = \text{_____ mVrms}$$

2. Use the BNC Tee and terminate the Tracking Generator RF OUTPUT in 50 ohms. Measure the rf output with the RF Vector Voltmeter. Record the reading:

$$V_L = \text{_____ mVrms}$$

3. Find the source resistance of the Tracking Generator by the following formula:

$$R_s = \frac{R_L V_{OC}}{V_L} - R_L$$

V_{OC} = Tracking Generator rf output open circuit voltage
 V_L = Tracking Generator rf output terminated in 50 ohms
 $R_L = Z_0 =$ Characteristic Impedance = 50 ohms

4. Find SWR by the formula:

$$SWR = \frac{Z_0}{R_s}$$

$$\left(\frac{R_s}{Z_0} \text{ if } Z_0 \text{ is greater than } R_s \right)$$

5. Record this value; maximum allowable is 1.2

$$1.2 \text{ _____ SWR}$$

4-14. Specification 5, Measurement Range

SPECIFICATION:

100 kHz to 110 MHz. Display: seven digits with one digit over-range (for frequencies of 100 MHz and higher).

DESCRIPTION:

This test is identical to 4-10.

PERFORMANCE TESTS (Cont.)

4-15. Specification 6, Resolution (Gate Time).

SPECIFICATION:

1 kHz (1 mSec), 100 Hz (10 mSec) and 10 Hz (100 mSec).

DESCRIPTION:

This test consists of placing the RESOLUTION switch on the 8443A in each of its three positions and observing the numerical readout.

PROCEDURE:

Operate the model 8443A in the MARKER mode with the MARKER POSITION knob pulled out. Tune the analyzer to any frequency over 100 MHz, and place the model 8443A RESOLUTION control in each of its three positions. In the 10 Hz position all of the numerical readouts are illuminated and the decimal point is between the third and fourth readouts. In the 100 Hz position the first numerical readout is blanked and the decimal point is between the fourth and fifth readouts. In the 1 kHz position the first and second readouts are blanked and the decimal point is between the fifth and sixth readouts.

4-16. Specification 7, Accuracy.

SPECIFICATION:

± 1 count \pm time base accuracy.

DESCRIPTION:

Connect the 1 MHz OUT (J4 on rear panel of the model 8443A) to the COUNTER INPUT. Place the MODE control in the EXTERNAL position. In any position of the RESOLUTION control the last digit of the numerical readout will be 0, 1 or 9.

4-17. Specification 8, Time Base Aging Rate.

SPECIFICATION:

$< 3 \times 10^{-9}$ per day. (0.3 Hz/day) after warmup.

DESCRIPTION:

This test checks long term frequency stability. This is accomplished by mixing the reference oscillator frequency of the model 8443A with a stable 1.000001 MHz signal and recording the drift on a strip recorder.

EQUIPMENT:

Digital-to-Analog Converter/Recorder
Frequency Counter
Double Balanced Mixer
Amplifier, dc to 1 MHz

Quartz Oscillator
Frequency Synthesizer
Oscilloscope
Attenuator

PERFORMANCE TESTS (Cont.)

4-17. Specification 8, Time Base Aging Rate (Cont.)

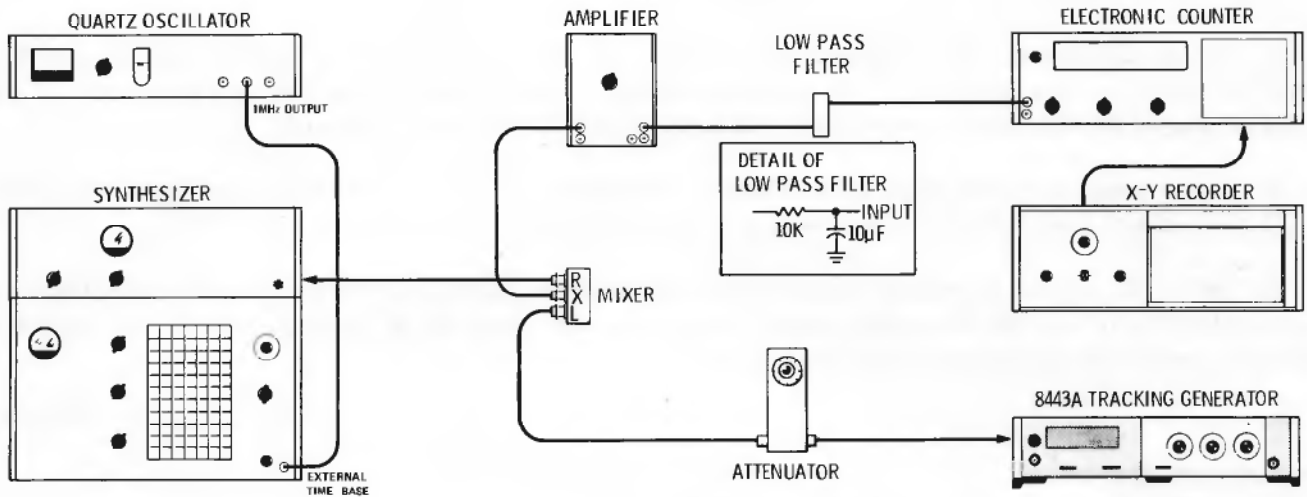

Figure 4-5. Time Base Aging Rate Test

PROCEDURE:

1. Set controls as follows:

DIGITAL-TO-ANALOG CONVERTER/RECORDER

POWER	ON	MIN-N-HR	HR
COLUMN SELECTOR	2, 3 and 4	div	8
OPERATE	(after ZERO-CALIBRATE procedure)	PEN	down
		RANGE	100 mV

AMPLIFIER, dc to 1 MHz:

Remove ground strap from low output terminal

QUARTZ OSCILLATOR:

OUTPUT From 1 MHz jack

FREQUENCY COUNTER:

SIGNAL INPUT	DC	SENSITIVITY (preset)	0.1V
TIME BASE	10 µS	FUNCTION to PERIOD AVERAGE	1
SAMPLE RATE	Just out of	STORAGE/OFF	
	POWER OFF detent	(on back panel)	STORAGE

TEST PROCEDURES (Cont.)

4-19. Specification 10, External Counter Input.

SPECIFICATION:

10 kHz to 120 MHz, 50 ohms, -10 dBm minimum, +25 dBm maximum.

DESCRIPTION:

This test verifies the ability of the counter to count frequencies between 10 kHz and 120 MHz at signal levels as low as -10 dBm.

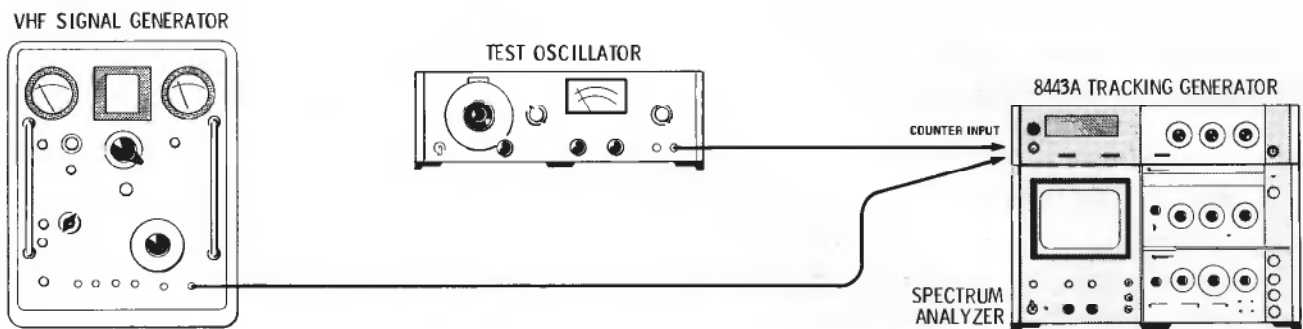

Figure 4-6. Counter Input Test Setup

EQUIPMENT:

Test Oscillator

VHF Signal Generator

PROCEDURE:

1. Place the model 8443A MODE switch in the EXTERNAL position and connect the test oscillator output to the COUNTER INPUT. Set the test oscillator output to 10 kHz at -10 dBm. The counter readout should indicate 10 kHz. Increase the test oscillator output to +25 dBm. Counter readout remains the same.
2. Connect the VHF Signal Generator RF OUTPUT to the model 8443A COUNTER INPUT. Set generator output to 120 MHz at -10 dBm. The counter readout should indicate 120 MHz.
3. Repeat the test at various frequencies between 10 kHz and 120 MHz.

PERFORMANCE TESTS (Cont.)

4-20. Specification 11, External Time Base.

SPECIFICATION:

1 MHz, 50 ohm, 1 V_{rms} minimum.

DESCRIPTION:

This test verifies proper operation of the counter when an external time base is used.

EQUIPMENT:

Frequency Standard

VHF Signal Generator

PROCEDURE:

1. Connect the signal generator RF OUTPUT to the model 8443A COUNTER INPUT (100 MHz, -10 dBm). Counter readout indicates 100 MHz.
 2. Connect the frequency standard output (1 MHz) to the model 8443A EXT TIME BASE IN (rear panel J3). Place A5S1 in the EXT position. The counter readout should again indicate 100 MHz.
-

4-21. Specification 12, Time Base Output.

SPECIFICATION:

1 MHz, 1 V_{rms} nominal.

DESCRIPTION:

This test verifies the presence of the internal time base signal at J4 on the rear panel of the model 8443A.

EQUIPMENT:

Oscilloscope

PROCEDURE:

Connect the 1 MHz OUT (rear panel J4) to the oscilloscope input. Oscilloscope displays a 1 MHz signal at least 1 V_{rms} in amplitude.

4-22. Specification 13, Digital Frequency Readout.

SPECIFICATION:

8, 4, 2, 1 code: positive logic.

DESCRIPTION:

This test verifies the availability of the digital output from the model 8443A.

EQUIPMENT:

Digital Recorder

PROCEDURE:

Connect the DIGITAL OUTPUT on the rear panel of the model 8443A to the digital recorder input. Place the UNBLANKED/BLANKED switch on the model 8443A to the BLANKED position (to prevent zero's before the first significant digit). In the EXTERNAL mode set the analyzer to 10 MHz/Div and 10 second/Div. Connect the RF OUTPUT to the COUNTER INPUT. Note that the digital recorder readout tracks (one count behind) the model 8443A counter readout.

Table 4-1. Performance Test Record

4-10. Frequency Range	100 kHz _____
	110 MHz _____
4-11. Amplitude Range	
	0 dBm reading: 298 mV _____ 302 mV
	-10 dBm reading: 298 mV _____ 302 mV
	-20 dBm reading: 298 mV _____ 302 mV
	-30 dBm reading: 298 mV _____ 302 mV
	-40 dBm reading: 298 mV _____ 302 mV
	-50 dBm reading: 298 mV _____ 302 mV
	-60 dBm reading: 298 mV _____ 302 mV
	-70 dBm reading: 298 mV _____ 302 mV
	-80 dBm reading: 298 mV _____ 302 mV
	-90 dBm reading: 298 mV _____ 302 mV
	-100 dBm reading: 298 mV _____ 302 mV
	-110 dBm reading: 298 mV _____ 302 mV
	-1 dBm reading: 299 mV _____ 301 mV
	-2 dBm reading: 299 mV _____ 301 mV
	-3 dBm reading: 299 mV _____ 301 mV
	-4 dBm reading: 299 mV _____ 301 mV
	-5 dBm reading: 299 mV _____ 301 mV
	-6 dBm reading: 299 mV _____ 301 mV
	-7 dBm reading: 299 mV _____ 301 mV
	-8 dBm reading: 299 mV _____ 301 mV
	-9 dBm reading: 299 mV _____ 301 mV
	-10 dBm reading: 299 mV _____ 301 mV
	-11 dBm reading: 299 mV _____ 301 mV
	-12 dBm reading: 299 mV _____ 301 mV
4-12. Amplitude Accuracy (Flatness).	±0.5 dB _____
4-13. Output Impedance.	1.2 _____ SWR
4-17. Time Base Aging Rate	_____ divisions
4-18. Time Base Temperature Drift	_____ deviation

SECTION V ADJUSTMENTS

5-1. INTRODUCTION.

5-2. This section describes adjustments and checks required to return the model 8443A to peak operation capability when repairs are required. Included in this section are test setups and procedures and a test card for recording data taken during adjustment procedures. Adjustment location illustrations are provided on the first foldout in this manual.

5-3. TEST EQUIPMENT.

5-4. Each test procedure in this section contains a list of test equipment to be used. Required specifications for test equipment are detailed in Table 1-2. Also, each test setup identifies all test equipment and accessories by callouts. Any equipment substituted for the instruments or accessories listed in Table 1-2 must meet the minimum specifications in order to adjust the model 8443A effectively.

5-5. HP 08443-60011 SERVICE KIT.

5-6. The HP 08443-60011 Service Kit is an accessory item available from Hewlett-Packard for use in maintaining the Model 8443A Tracking Generator/Counter.

5-7. Table 1-2 contains a detailed description of the contents of the service kit. Any item in the kit may be ordered separately if desired.

5-8. FACTORY SELECTED COMPONENTS.

5-9. Some component values in the model 8443A are selected at the time of final assembly and test. These components are listed in Table 8-1. They are also listed in the adjustment procedure for the circuit in which they appear.

5-10. CHECKS AND ADJUSTMENT ARRANGEMENT.

5-11. The check and adjustment procedures are arranged in numerical order.

5-12. CHECKS AND ADJUSTMENTS.

5-13. Power Supplies Checks and Adjustments.

REFERENCE:
Service Sheet 4.

DESCRIPTION:
The power supplies in the model 8443A provide regulated outputs of +175 volts, +24 volts, +20 volts, +5.8 volts and -12 volts. These checks verify proper operation of the power supplies.

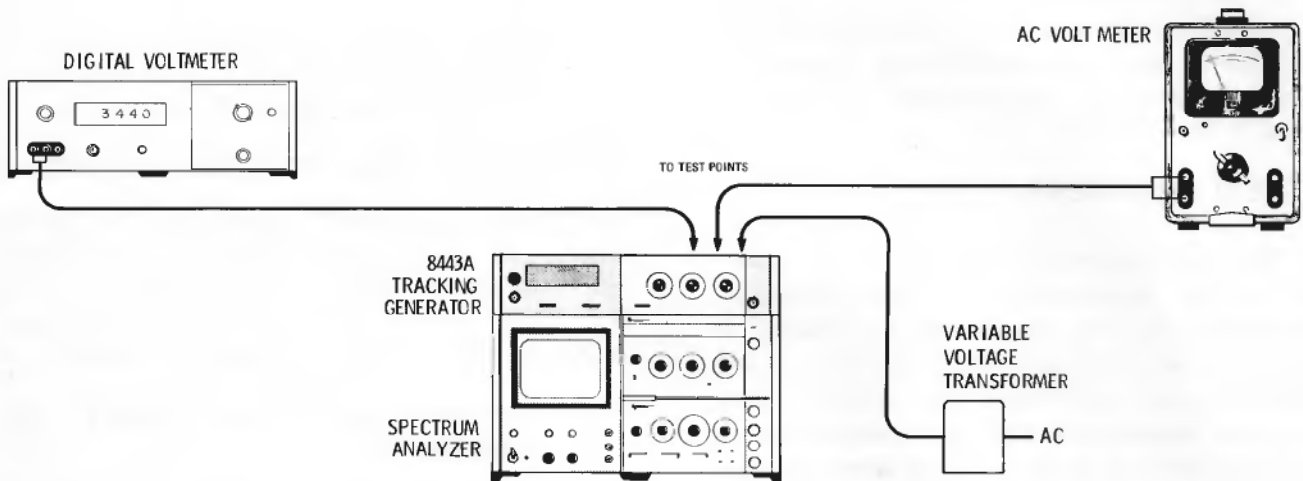

Figure 5-1. Power Supply Test Setup

EQUIPMENT:
Digital Voltmeter
AC Voltmeter
Service Kit

Variable Voltage
Transformer

PROCEDURE:

1. With power applied to the model 8443A through the variable voltage transformer, connect the digital voltmeter to the +24 volt test point on the A14 assembly. Vary the ac line voltage from 100 volts to 130 volts. The +24 volts should not vary more than ± 10 mV.

Input AC	+24V
100 vac	_____
115 vac	_____
130 vac	_____

2. Measure the dc levels and the ac ripple at the test points on the A14 Sense Amplifier.

Level	Tolerance	Ripple
+24V	± 10 mV	<0.2 mV
+20V	± 0.4 V	<1 mV
+5.8V	± 0.12 V	<1 mV
-12V	± 0.24 V	<1 mV

CHECKS AND ADJUSTMENTS (Cont.)

5-13. Power Supplies Checks and Adjustments (Cont.)

3. Measure the dc level and ac ripple at the 175V test point.

Level	Tolerance	Ripple
+175V	±3.5V	<1V

4. If the voltages are not within tolerance connect the digital voltmeter to the +24 volt test point on the A14 assembly and adjust reference level potentiometer R50. If the voltage cannot be adjusted to +24 volts, or if other dc outputs are not within tolerance, refer to Service Sheet 4 in Section VIII and repair the power supply. Repeat these tests after completing repairs.

Note

R11, R33, R38 and R43 are all factory selected at time of final assembly to provide the proper reference level for the sense amplifier in which they appear. The value of these resistors determines the dc level of the supply output.

5-14. First Converter (A13) Checks and Adjustments

REFERENCE:
Service Sheet 2.

DESCRIPTION:
The first converter contains a 3 MHz crystal controlled oscillator, 3 MHz and 47 MHz amplifiers and a diode quad mixer. These tests verify proper operation of the assembly.

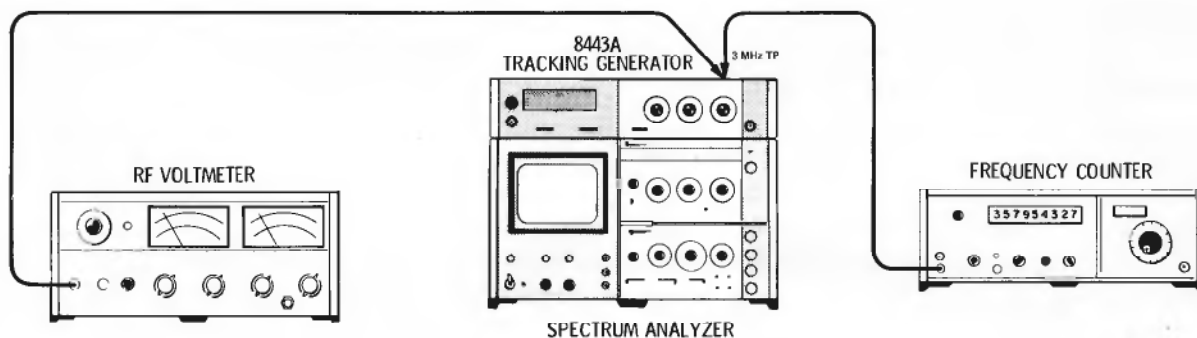

Figure 5-2. First Converter Test Setup

CHECKS AND ADJUSTMENTS (Cont.)

5-14. First Converter (A13) Checks and Adjustments (Cont.)

EQUIPMENT:

RF Voltmeter
Service Kit

Frequency Counter

PROCEDURE:

1. Set the TRACKING ADJUST control full ccw and monitor the 3 MHz test point on the A13 assembly with the RF Voltmeter. Adjust L1 PEAK ADJ for maximum indication on the RF Voltmeter.

2. Monitor the 3 MHz test point with the Frequency Counter and set L2, RANGE ADJ, for a frequency of 2.99982 MHz.

3. Turn the TRACKING ADJUST control full cw. The frequency at the 3 MHz test point should be 3.00025 MHz. If the frequency is greater than 3.00025 MHz, replace R20 with a higher value.

4. Connect the RF Voltmeter to the 3 MHz test point. The minimum output level over the range of the TRACKING ADJUST control should be 275 mVrms.

275 mVrms _____

5. Remove the A13 assembly and reinstall it using an extender board. Measure the output of the 3 MHz oscillator (Test Point 4) with the RF Voltmeter. Signal level should be 480 mVrms minimum.

480 mVrms _____

6. Reinstall the A13 assembly and connect the 50 MHz output to the Spectrum Analyzer RF INPUT. The 50 MHz signal should be -26 dBm minimum.

-26 dBm _____

5-15. 50 MHz IF Amplifier (A12) Checks and Adjustments.

REFERENCE:

Service Sheet 2.

DESCRIPTION:

The 50 MHz amplifier provides about 12 dB of gain. These tests verify proper operation of the bandpass filter and the 44 and 47 MHz traps.

EQUIPMENT:

Service Kit

PROCEDURE:

1. Connect the output of the A12 assembly to the Spectrum Analyzer RF INPUT. Adjust the BPF ADJ capacitors for maximum 50 MHz signal on the analyzer CRT. Minimum signal level is -15 dBm.

-15 dBm _____

2. Adjust C8 and C17 for minimum signal at 44 MHz and C10 for minimum signal at 47 MHz. Check for minimum separation of 60 dB between the 50 MHz signal and the 44 and 47 MHz signals over the entire range of the analyzer's third local oscillator signal.

Separation 60 dB _____

CHECKS AND ADJUSTMENTS (Cont.)

5-16. Second Converter (A11) Checks and Adjustments.

REFERENCE:

Service Sheet 2.

DESCRIPTION:

The second converter contains a three-stage amplifier (about 20 dB gain) and a diode quad mixer. These tests verify proper operation of the assembly.

EQUIPMENT:

Service Kit

RF Voltmeter

PROCEDURE:

1. Remove the A11 assembly and reinstall it using an extender board. Check the output from the amplifier to the mixer (Test Point 1) with the RF Voltmeter. Level should be 800 mVrms minimum.

800 mVrms _____

2. Check the 200 MHz output with the RF Voltmeter (terminated in 50 ohms). Minimum level should be -22 dBm.

-22 dBm _____

5-17. 200 MHz IF Amplifier (A10) Checks and Adjustments.

REFERENCE:

Service Sheet 3.

DESCRIPTION:

The A10 assembly contains a two-stage variable gain (about 20 dB) amplifier and a bandpass filter. These tests verify proper operation of the assembly.

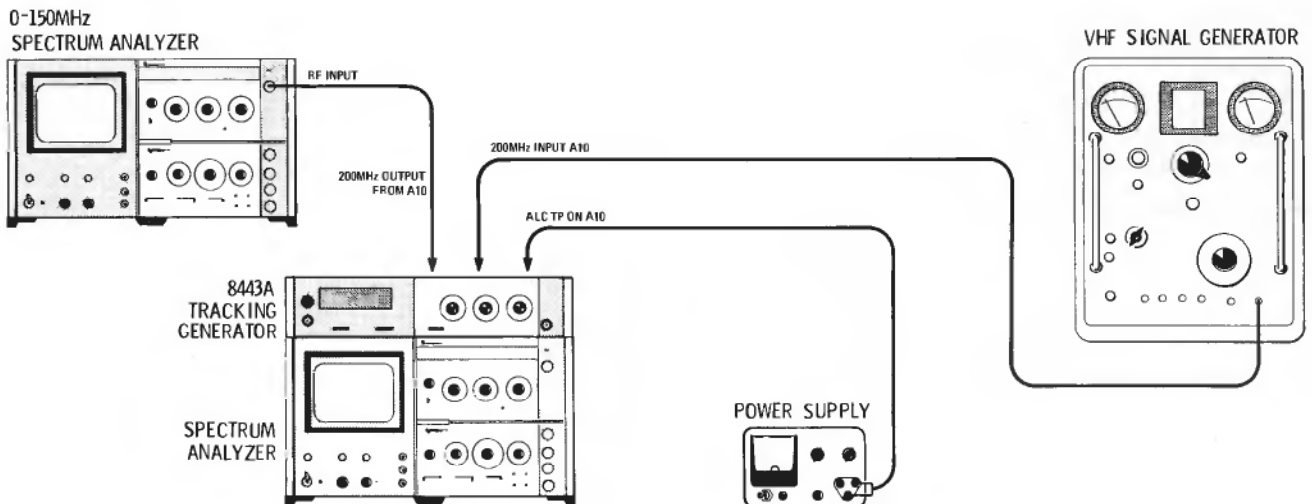

Figure 5-3. 200 MHz IF Test Setup

CHECKS AND ADJUSTMENTS (Cont.)

5-17. 200 MHz IF Amplifier (A10) Checks and Adjustments (Cont.)

EQUIPMENT:

VHF Signal Generator
Service Kit

0 – 1250 MHz Spectrum Analyzer
DC Power Supply

PROCEDURE:

1. Apply a -10 dBm, 100 MHz, CW signal to the 200 MHz input on the A10 assembly. Connect the 200 MHz output of the A10 assembly to the RF INPUT of the 0 – 1250 MHz Spectrum Analyzer and tune the analyzer to 100 MHz. Adjust A10C5 for minimum response on the analyzer CRT.
2. Change the input signal to 150 MHz and adjust A10C4 for minimum 150 MHz response.
3. Change the input signal to 200 MHz, center the signal on the 0 – 1250 Spectrum Analyzer CRT and adjust the bandpass filter (C3, C5 and C6) for maximum response. Reduce the output of the signal generator to -35 dBm. The signal level displayed on the 0 – 1250 Spectrum Analyzer should be -18 dB (17 dB gain).
4. Remove the A8 assembly and apply a 23 volt dc level to the ALC Test Point on the A10 assembly. Tune the ALC RANGE ADJ for minimum signal level out as observed on the 0 – 1250 Spectrum Analyzer CRT.

5-18. Third Converter (A9) Checks and Adjustments.

REFERENCE:

Service Sheet 3.

DESCRIPTION:

The third converter assembly contains a three-stage (about 20 dB gain) amplifier, a diode quad mixer and a 120 MHz low pass filter. These tests verify proper operation of the assembly.

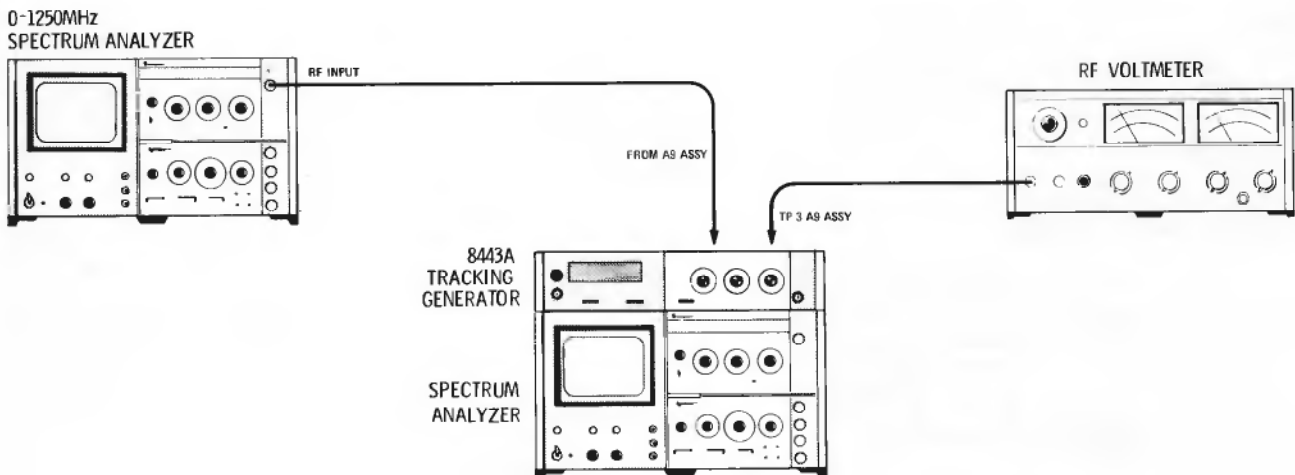

Figure 5-4. Third Converter Test Setup

CHECKS AND ADJUSTMENTS (Cont.)

5-18. Third Converter (A9) Checks and Adjustments (Cont.)

EQUIPMENT:

- RF Voltmeter
- 0 – 1250 MHz Spectrum Analyzer

Service Kit

PROCEDURE:

1. Remove the A9 assembly and reinstall it using an extender board from the service kit. Check the amplifier output at Test Point 3 (Q1-c). Signal level should be 800 mVrms minimum.

800 mVrms _____

2. Connect the output of the A9 assembly to the analyzer RF INPUT. Signal level should be -32 dB minimum.

-32 dBm _____

3. Connect the output of the A9 assembly to the RF INPUT of the 0 – 1250 MHz Spectrum Analyzer and verify that frequencies above 120 MHz are sharply attenuated.

5-19. ALC/Video Amplifier Checks and Adjustments.

REFERENCE:

Service Sheet 3.

DESCRIPTION:

The A8 assembly contains two integrated circuit rf amplifiers and a leveling circuit which controls the gain of the 200 MHz IF amplifier. These tests verify proper operation of the assembly.

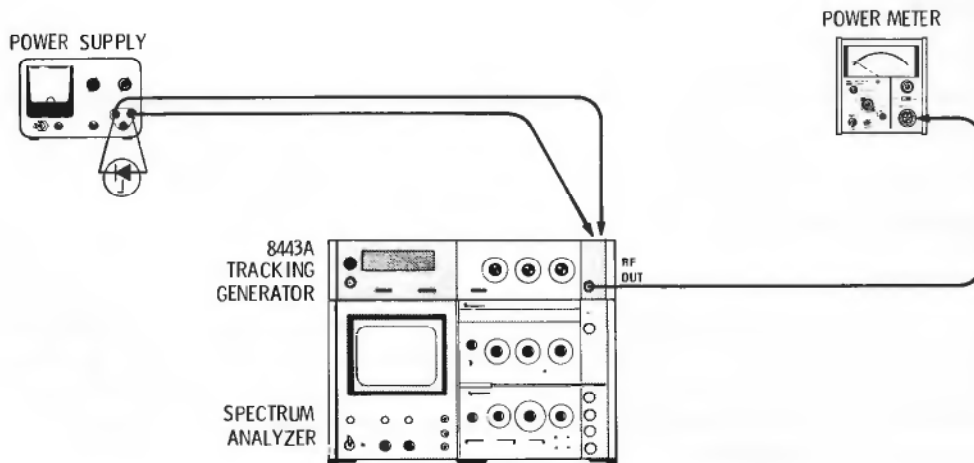

Figure 5-5. ALC/Video Amplifier Test Setup

CHECKS AND ADJUSTMENTS (Cont.)

5-19. ALC/Video Amplifier Checks and Adjustments (Cont.)

EQUIPMENT:

Power Supply
Service Kit

Power Meter
3.7 Volt Zener Diode

PROCEDURE:

1. Connect the 3.7 volt zener diode across the power supply output terminals. Connect the negative power supply lead to the CCW lead of the output vernier control and the positive lead to ground.
 2. Set the OUTPUT LEVEL dBm TENS to +10 and connect the power meter to the RF OUTPUT. Set the analyzer to ZERO scan at 100 MHz.
 3. Set OUTPUT LEVEL ONES to -9 and TENTHS to -.1. Adjust the power supply for a 0 dBm output from the model 8443A as read on the power meter.
 4. Set OUTPUT LEVEL dBm ONES to -10 and TENTHS to 0. Adjust R16, 0 dB ADJ, on the A8 assembly for a 0 dBm output from the model 8443A as read on the power meter.
 5. Repeat steps 3 and 4 until further adjustment is unnecessary.
 6. Disconnect the power supply and set OUTPUT LEVEL dBm ONES to -9 and TENTHS to -.1.
 7. Adjust -1 dB ADJ on the A8 assembly for a 0 dBm output from the model 8443A as read on the power meter.
 8. Set OUTPUT LEVEL dBm ONES to -10 and TENTHS to 0. Verify 0 dBm output with the power meter.
-

5-20. Reference Oscillator (A4) Checks and Adjustments.

REFERENCE:

Service Sheet 7.

DESCRIPTION:

This procedure allows adjustment of the reference oscillator (A4) in comparison with an external frequency standard.

EQUIPMENT:

1 MHz Frequency Standard

Oscilloscope

PROCEDURE:

After warmup (seven continuous days of operation or 72 hours of operation after an off time of 72 hours or less), connect the oscilloscope and frequency standard as shown in Figure 5-6; set the oscilloscope to .05 μ Sec/Div and adjust the vertical sensitivity for full scale sinusoid. Adjust the reference oscillator COARSE and FINE controls until the display moves in either direction no faster than one division in five seconds.

CHECKS AND ADJUSTMENTS (Cont.)

5-20. Reference Oscillator (A4) Checks and Adjustments (Cont.)

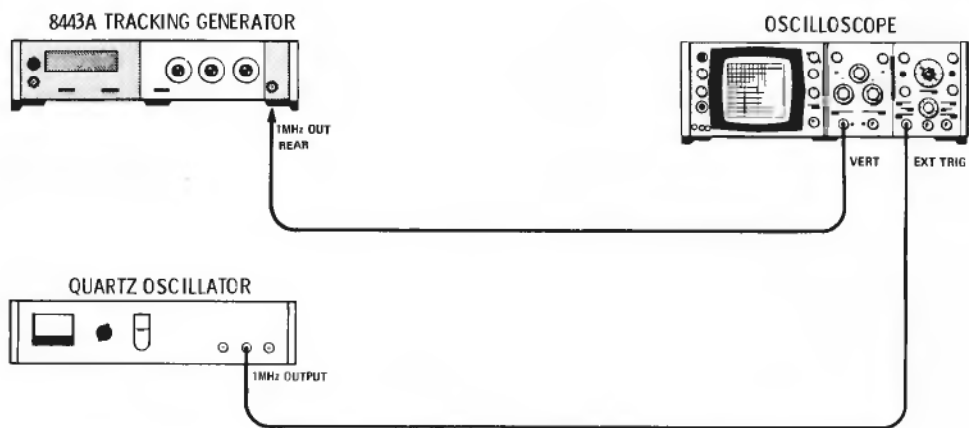

Figure 5-6. Reference Oscillator Test Setup

Table 5-1. Performance Test Record

Hewlett-Packard Model 8443A Tracking Generator/Counter	Tests Performed by _____																																												
Serial No. _____	Date _____																																												
<p>5-13. Power Supplies Checks and Adjustments.</p> <p>+24 volt supply at 100 vac _____ at 115 vac _____ at 130 vac _____</p> <table style="width: 100%; border-collapse: collapse;"> <thead> <tr> <th style="text-align: left; width: 35%;">Power Supply:</th> <th style="text-align: center; width: 30%;">Measured Level</th> <th style="text-align: center; width: 35%;">Measured ripple</th> </tr> </thead> <tbody> <tr> <td>+24V</td> <td style="text-align: center;">_____</td> <td style="text-align: center;">_____</td> </tr> <tr> <td>+20V</td> <td style="text-align: center;">_____</td> <td style="text-align: center;">_____</td> </tr> <tr> <td>+5.8V</td> <td style="text-align: center;">_____</td> <td style="text-align: center;">_____</td> </tr> <tr> <td>-12V</td> <td style="text-align: center;">_____</td> <td style="text-align: center;">_____</td> </tr> <tr> <td>+175V</td> <td style="text-align: center;">_____</td> <td style="text-align: center;">_____</td> </tr> </tbody> </table> <p>5-14. First Converter (A13) Checks and Adjustments.</p> <table style="width: 100%; border-collapse: collapse;"> <thead> <tr> <th style="text-align: left; width: 60%;">Test</th> <th style="width: 40%;"></th> </tr> </thead> <tbody> <tr> <td style="text-align: center;">4</td> <td style="text-align: right;">275 mVrms _____</td> </tr> <tr> <td style="text-align: center;">5</td> <td style="text-align: right;">480 mVrms _____</td> </tr> <tr> <td style="text-align: center;">6</td> <td style="text-align: right;">-26 dBm _____</td> </tr> </tbody> </table> <p>5-15. 50 MHz IF Amplifier (A12) Checks and Adjustments.</p> <table style="width: 100%; border-collapse: collapse;"> <thead> <tr> <th style="text-align: left; width: 60%;">Test</th> <th style="width: 40%;"></th> </tr> </thead> <tbody> <tr> <td style="text-align: center;">1</td> <td style="text-align: right;">-15 dBm _____</td> </tr> <tr> <td style="text-align: center;">2</td> <td style="text-align: right;">Separation 60 dB _____</td> </tr> </tbody> </table> <p>5-16. Second Converter (A11) Checks and Adjustments.</p> <table style="width: 100%; border-collapse: collapse;"> <thead> <tr> <th style="text-align: left; width: 60%;">Test</th> <th style="width: 40%;"></th> </tr> </thead> <tbody> <tr> <td style="text-align: center;">1</td> <td style="text-align: right;">800 mVrms _____</td> </tr> <tr> <td style="text-align: center;">2</td> <td style="text-align: right;">-22 dBm _____</td> </tr> </tbody> </table> <p>5-18. Third Converter (A9) Checks and Adjustments.</p> <table style="width: 100%; border-collapse: collapse;"> <thead> <tr> <th style="text-align: left; width: 60%;">Test</th> <th style="width: 40%;"></th> </tr> </thead> <tbody> <tr> <td style="text-align: center;">1</td> <td style="text-align: right;">800 mVrms _____</td> </tr> <tr> <td style="text-align: center;">2</td> <td style="text-align: right;">-32 dBm _____</td> </tr> </tbody> </table>		Power Supply:	Measured Level	Measured ripple	+24V	_____	_____	+20V	_____	_____	+5.8V	_____	_____	-12V	_____	_____	+175V	_____	_____	Test		4	275 mVrms _____	5	480 mVrms _____	6	-26 dBm _____	Test		1	-15 dBm _____	2	Separation 60 dB _____	Test		1	800 mVrms _____	2	-22 dBm _____	Test		1	800 mVrms _____	2	-32 dBm _____
Power Supply:	Measured Level	Measured ripple																																											
+24V	_____	_____																																											
+20V	_____	_____																																											
+5.8V	_____	_____																																											
-12V	_____	_____																																											
+175V	_____	_____																																											
Test																																													
4	275 mVrms _____																																												
5	480 mVrms _____																																												
6	-26 dBm _____																																												
Test																																													
1	-15 dBm _____																																												
2	Separation 60 dB _____																																												
Test																																													
1	800 mVrms _____																																												
2	-22 dBm _____																																												
Test																																													
1	800 mVrms _____																																												
2	-32 dBm _____																																												

SECTION VI REPLACEABLE PARTS

6-1. This section contains information relative to ordering replacement parts and assemblies.

6-2. Table 6-1 provides correct stock numbers for use when ordering printed circuit board assemblies on an exchange basis.

6-3. Table 6-2 provides an index of reference designations and abbreviations used in the preparation of manuals by Hewlett-Packard.

6-4. Table 6-3 identifies parts by reference designations.

6-5. Table 6-4 lists replaceable parts in stock number sequence.

6-6. Table 6-5 provides code number identification of manufacturers.

Table 6-1. Part Numbers for Assembly Exchange Orders

Assembly	New Part No.	Exchange No.
A1 Low Frequency Counter	08443-60066	08443-60101
A5 Time Base	08443-60048	08443-60104
A6 High Frequency Decade	08443-60047	08443-60105
A7 Marker Control	08443-60046	08443-60106
A8 ALC Video Amplifier	08443-60045	08443-60107
A9 Third Converter	08443-60044	08443-60108
A10 200 MHz IF Amplifier	08443-60043	08443-60109
A11 Second Converter	08443-60042	08443-60110
A12 50 MHz IF Amplifier	08443-60041	08443-60111
A13 First Converter	08443-60040	08443-60112
A14 Sense Amplifier	08443-60015	08443-60113
A15 Rectifier	08443-60014	08443-60114

Table 6-2. Reference Designators and Abbreviations

REFERENCE DESIGNATORS							
A	= assembly	F	= fuse	P	= plug	V	= vacuum tube, neon bulb, photocell, etc.
B	= motor	FL	= Filter	Q	= transistor	VR	= voltage regulator
BT	= battery	J	= jack	R	= resistor	W	= cable
C	= capacitor	K	= relay	RT	= thermistor	X	= socket
CP	= coupler	L	= inductor	S	= switch	Y	= crystal
CR	= diode	LS	= loud speaker	T	= transformer	Z	= tuned cavity, network
DL	= delay line	M	= meter	TB	= terminal board		
DS	= device signaling (lamp)	MK	= microphone	TP	= test point		
E	= misc electronic part	MP	= mechanical part	U	= integrated circuit		

ABBREVIATIONS							
A	= amperes	H	= henries	N/O	= normally open	RMO	= rack mount only
AFC	= automatic frequency control	HDW	= hardware	NOM	= nominal	RMS	= root-mean square
AMPL	= amplifier	HEX	= hexagonal	NPO	= negative positive zero (zero temperature coefficient)	RWV	= reverse working voltage
BFO	= beat frequency oscillator	HG	= mercury			S-B	= slow-blow
BE CU	= beryllium copper	HR	= hour(s)	NPN	= negative-positive-negative	SCR	= screw
BH	= binder head	Hz	= Hertz	NRFR	= not recommended for field replacement	SE	= selenium
BP	= bandpass	IF	= intermediate freq	NSR	= not separately replaceable	SECT	= section(s)
BRS	= brass	IMPG	= impregnated	OBD	= order by description	SEMICON	= semiconductor
BWO	= backward wave oscillator	INCD	= incandescent	OH	= oval head	SI	= silicon
		INCL	= include(s)	OX	= oxide	SIL	= silver
		INS	= insulation(ed)	P	= peak	SL	= slide
		INT	= internal	PC	= printed circuit	SPG	= spring
CCW	= counterclockwise	K	= kilo = 1000	PF	= picofarads = 10 ⁻¹² farads	SPL	= special
CER	= ceramic	LH	= left hand	PH BRZ	= phosphor bronze	SST	= Stainless steel
CMO	= cabinet mount only	LIN	= linear taper	PHL	= Phillips	SR	= split ring
COEF	= coefficient	LK WASH	= lock washer	PIV	= peak inverse voltage	STL	= steel
COM	= common	LOG	= logarithmic taper	P/O	= part of	TA	= tantalum
COMP	= composition	LPF	= low pass filter	POLY	= polystrene	TD	= time delay
COMPL	= complete	M	= milli = 10 ⁻³	PORC	= porcelain	TGL	= toggle
CONN	= connector	MEG	= meg = 10 ⁶	POS	= position(s)	THD	= thread
CP	= cadmium plate	MET FLM	= metal film	POT	= potentiometer	TI	= titanium
CRT	= cathode-ray tube	MET OX	= metallic oxide	PP	= peak-to-peak	TOL	= tolerance
CW	= clockwise	MFR	= manufacturer	PT	= point	TRIM	= trimmer
DEPC	= deposited carbon drive	MHz	= mega Hertz	PWV	= peak working voltage	TWT	= traveling wave tube
ELECT	= electrolytic	MINAT	= miniature	RECT	= rectifier		
ENCAP	= encapsulated	MOM	= momentary	RF	= radio frequency		
EXT	= external	MOS	= metalized substrate	RH	= round head or right hand		
F	= farads	MTG	= mounting				
FH	= flat head	MY	= "mylar"				
FIL H	= Fillister head	N	= nano (10 ⁻⁹)				
FXD	= fixed	N/C	= normally closed				
G	= giga (10 ⁹)	NE	= neon				
GE	= germanium	NI PL	= nickel plate				
GL	= glass						
GRD	= ground(ed)						

Table 6-3. Parts Indexed by Reference Designation

Reference Designation	Part No.	Description #	Note
A1	08443-60066	LOW FREQUENCY COUNTER ASSY	
A1DS1	08443-60101 1970-0042	EXCHANGE LOW FREQUENCY COUNTER ASSY TUBE:NUMERICAL INDICATOR	
A1DS2	1970-0042	TUBE:NUMERICAL INDICATOR	
A1DS3	1970-0042	TUBE:NUMERICAL INDICATOR	
A1DS4	1970-0042	TUBE:NUMERICAL INDICATOR	
A1DS5	1970-0042	TUBE:NUMERICAL INDICATOR	
A1DS6	1970-0042	TUBE:NUMERICAL INDICATOR	
A1DS7	1970-0042	TUBE:NUMERICAL INDICATOR	
A1DS8	1970-0042	TUBE:NUMERICAL INDICATOR	
A1MP1	08443-00009	COVER:TOP COUNTER BOX	
A1MP2	08443-00016	BRACKET:RETAINING	
A1MP3	08443-00042	COUNTER BOX	
A1MP4	08443-00044	GUIDE:CONNECTOR BOARD	
A1MP5	08443-60039	BOARD ASSY:CONNECTOR	
A1MP6	0400-0009	GROMMET:VINYL FITS 1/4" DIA HOLE	
A1MP7	0400-0009	GROMMET:VINYL FITS 1/4" DIA HOLE	
A1MP8	0400-0009	GROMMET:VINYL FITS 1/4" DIA HOLE	
A1MP9	0400-0009	GROMMET:VINYL FITS 1/4" DIA HOLE	
A1MP10	0400-0009	GROMMET:VINYL FITS 1/4" DIA HOLE	
A1MP11	0400-0009	GROMMET:VINYL FITS 1/4" DIA HOLE	
A1MP12	0400-0009	GROMMET:VINYL FITS 1/4" DIA HOLE	
A1MP13	0400-0009	GROMMET:VINYL FITS 1/4" DIA HOLE	
A1W1	08443-60064	CABLE ASSY	
A1A1	08443-60037	BOARD ASSY:LOW FREQ COUNTER	
	08443-20037	BOARD:BLANK PC	
A1A1C1	0160-2143	C:FXD CER 2000 PF +80-20% 1000VDCW	
A1A1C2	0160-2143	C:FXD CER 2000 PF +80-20% 1000VDCW	
A1A1C3	0160-2930	C:FXD CER 0.01 UF +80-20% 100VDCW	
A1A1C4	0180-0197	C:FXD ELECT 2.2 UF 10% 20VDCW	
A1A1C5	0180-0137	C:FXD ELECT 100 UF 20% 10VDCW	
A1A1CR1	1901-0025	DIODE:SILICON 100MA/1V	
A1A1CR2	1901-0025	DIODE:SILICON 100MA/1V	
A1A1CR3	1901-0025	DIODE:SILICON 100MA/1V	
A1A1CR4	1901-0025	DIODE:SILICON 100MA/1V	
A1A1CR5	1901-0025	DIODE:SILICON 100MA/1V	
A1A1DS1	1970-0042	TUBE:NUMERICAL INDICATOR	
A1A1DS2	1200-0405 1970-0042	SOCKET:TUBE FOR 5700 SERIES TUBE:NUMERICAL INDICATOR	
A1A1DS3	1200-0405 1970-0042	SUCKET:TUBE FOR 5700 SERIES TUBE:NUMERICAL INDICATOR	

See introduction to this section for ordering information

Table 6-3. Parts Indexed by Reference Designation (Cont.)

Reference Designation	Part No.	Description #	Note
A1A1DS4	1200-0405 1970-0042	SOCKET:TUBE FOR 5700 SERIES TUBE:NUMERICAL INDICATOR	
A1A1DS5	1200-0405 1970-0042 1200-0405	SOCKET:TUBE FOR 5700 SERIES TUBE:NUMERICAL INDICATOR SOCKET:TUBE FOR 5700 SERIES	
A1A1DS6	1970-0042 1200-0405	TUBE:NUMERICAL INDICATOR SOCKET:TUBE FOR 5700 SERIES	
A1A1DS7	1970-0042 1200-0405	TUBE:NUMERICAL INDICATOR SOCKET:TUBE FOR 5700 SERIES	
A1A1DS8	1970-0042 1200-0405	TUBE:NUMERICAL INDICATOR SOCKET:TUBE FOR 5700 SERIES	
A1A1L1	9100-1643	COIL/CHOKE 300 UH 5%	
A1A1L2	9100-1616	COIL/CHOKE 1.50 UH 10%	
A1A1L3	9140-0051	COIL:FXD 400 UHY	
A1A1Q1	1854-0022	Q:SI NPN	
A1A1Q2	1854-0071	Q:SI NPN(SELECTED FROM 2N3704)	
A1A1Q3	1854-0022	Q:SI NPN	
A1A1Q4	1854-0022	Q:SI NPN	
A1A1Q5	1854-0022	Q:SI NPN	
A1A1R1	0683-6825	R:FXD COMP 6800 OHM 5% 1/4W	
A1A1R2	0683-6825	R:FXD COMP 6800 OHM 5% 1/4W	
A1A1R3	0683-3025	R:FXD COMP 3000 OHM 5% 1/4W	
A1A1R4	0683-6825	R:FXD COMP 6800 OHM 5% 1/4W	
A1A1R5	0683-3025	R:FXD COMP 3000 OHM 5% 1/4W	
A1A1R6	0683-6825	R:FXD COMP 6800 OHM 5% 1/4W	
A1A1R7	0683-3025	R:FXD COMP 3000 OHM 5% 1/4W	
A1A1R8	0683-6825	R:FXD COMP 6800 OHM 5% 1/4W	
A1A1R9	0683-3025	R:FXD COMP 3000 OHM 5% 1/4W	
A1A1R10	0683-6825	R:FXD COMP 6800 OHM 5% 1/4W	
A1A1R11	0683-6825	R:FXD COMP 6800 OHM 5% 1/4W	
A1A1R12	0683-6825	R:FXD COMP 6800 OHM 5% 1/4W	
A1A1R13	0683-1025	R:FXD COMP 1000 OHM 5% 1/4W	
A1A1R14	0683-3025	R:FXD COMP 3000 OHM 5% 1/4W	
A1A1R15	0683-3025	R:FXD COMP 3000 OHM 5% 1/4W	
A1A1U1	1820-0092	INTEGRATED CIRCUIT:DECODER-DIVIDER	
A1A1U2	1820-0092	INTEGRATED CIRCUIT:DECODER-DIVIDER	
A1A1U3	1820-0092	INTEGRATED CIRCUIT:DECODER-DIVIDER	
A1A1U4	1820-0092	INTEGRATED CIRCUIT:DECODER-DIVIDER	
A1A1U5	1820-0092	INTEGRATED CIRCUIT:DECODER-DIVIDER	
A1A1U6	1820-0092	INTEGRATED CIRCUIT:DECODER-DIVIDER	
A1A1U7	1820-0092	INTEGRATED CIRCUIT:DECODER-DIVIDER	
A1A1U8	1820-0116	IC:4-BIT BUFF STORE GATED OUTS	
A1A1U9	1820-0116	IC:4-BIT BUFF STORE GATED OUTS	
A1A1U10	1820-0116	IC:4-BIT BUFF STORE GATED OUTS	

See introduction to this section for ordering information

Table 6-3. Parts Indexed by Reference Designation (Cont.)

Reference Designation	Part No.	Description #	Note
A1A1U11	1820-0116	IC:4-BIT BUFF STORE GATED OUTS	
A1A1U12	1820-0116	IC:4-BIT BUFF STORE GATED OUTS	
A1A1U13	1820-0116	IC:4-BIT BUFF STORE GATED OUTS	
A1A1U14	1820-0116	IC:4-BIT BUFF STORE GATED OUTS	
A1A1U15	1820-0077	IC:TTL DUAL D FF (LATCH)	
A1A1U16	1820-0117	INTEGRATED CIRCUIT	
A1A1U17	1820-0119	INTEGRATED CIRCUIT	
A1A1U18	1820-0119	INTEGRATED CIRCUIT	
A1A1U19	1820-0119	INTEGRATED CIRCUIT	
A1A1U20	1820-0119	INTEGRATED CIRCUIT	
A1A1U21	1820-0119	INTEGRATED CIRCUIT	
A1A1U22	1820-0174	INTEGRATED CIRCUIT:TTL HEX INVERTER	
A2	08443-60001	ATTENUATOR ASSY:10 DB	
A2C1	0150-0011	C:FXD TI 1.5 PF 20% 500VDCW FACTORY SELECTED PART	
A2K1	0727-0091	R:FXD DEPC 790 OHM 1/2% 1/2W	
A2R2	0727-0028	R:FXD DEPC 53.3 OHM 1/2% 1/2W	
A2R3	0727-0028	R:FXD DEPC 53.3 OHM 1/2% 1/2W	
A2R4	0727-0028	R:FXD DEPC 53.3 OHM 1/2% 1/2W	
A2R5	0727-0091	R:FXD DEPC 790 OHM 1/2% 1/2W	
A2R6	0727-0028	R:FXD DEPC 53.3 OHM 1/2% 1/2W	
A2R7	0727-0042	R:FXD DEPC 96.25 OHM 1/2% 1/2W	
A2R8	0727-0037	R:FXD DEPC 71.16 OHM 1/2% 1/2W	
A2R9	0727-0042	R:FXD DEPC 96.25 OHM 1/2% 1/2W	
A2R10	0727-0034	R:FXD DEPC 61.11 OHM 1/2% 1/2W	
A2R11	0727-0062	R:FXD DEPC 247.5 OHM 1/2% 1/2W	
A2K12	0727-0034	R:FXD DEPC 61.11 OHM 1/2% 1/2W	
A2R13	0727-0028	R:FXD DEPC 53.3 OHM 1/2% 1/2W	
A2R14	0727-0091	R:FXD DEPC 790 OHM 1/2% 1/2W	
A2R15	0727-0028	R:FXD DEPC 53.3 OHM 1/2% 1/2W	
A3	08443-60002	ATTENUATOR ASSY:1 DB	
A3R1	0727-0010	R:FXD DEPC 17.61 OHM 1/2% 1/2W	
A3R2	0727-0064	R:FXD DEPC 292.4 OHM 1/2% 1/2W	
A3R3	0727-0379	R:FXD DEPC 146.2 OHM 1/2% 1/2W	
A3R4	0727-0010	R:FXD DEPC 17.61 OHM 1/2% 1/2W	
A3R5	0727-0064	R:FXD DEPC 292.4 OHM 1/2% 1/2W	
A3R6	0727-0094	R:FXD DEPC 870 OHM 1/2% 1/2W	
A3R7	0727-0005	R:FXD DEPC 5.77 OHM 1/2% 1/2W	
A3R8	0727-0094	R:FXD DEPC 870 OHM 1/2% 1/2W	
A3R9	0727-0074	R:FXD DEPC 436 OHM 1/2% 1/2W	
A3R10	0727-0008	R:FXD DEPC 11.61 OHM 1/2% 1/2W	
A3R11	0727-0074	R:FXD DEPC 436 OHM 1/2% 1/2W	
A3R12	0727-0064	R:FXD DEPC 292.4 OHM 1/2% 1/2W	
A3R13	0727-0010	R:FXD DEPC 17.61 OHM 1/2% 1/2W	
A3R14	0727-0064	R:FXD DEPC 292.4 OHM 1/2% 1/2W	
A4	0960-0079	OSCILLATOR-CRYSTAL ASSY: 1.0 MHZ	

See introduction to this section for ordering information

Table 6-3. Parts Indexed by Reference Designation (Cont.)

Reference Designation	Part No.	Description #	Note
A5	08443-60048 08443-60104 08443-20035	BOARD ASSY:TIME BASE EXCHANGE TIME BASE ASSY BOARD:BLANK PC	
A5C1	0160-2055	C:FXD CER 0.01 UF +80-20% 100VDCW	
A5C2	0160-2055	C:FXD CER 0.01 UF +80-20% 100VDCW	
A5C3	0160-2055	C:FXD CER 0.01 UF +80-20% 100VDCW	
A5C4	0160-2055	C:FXD CER 0.01 UF +80-20% 100VDCW	
A5C5	0160-2218	C:FXD MICA 1000 PF 5%	
A5C6	0180-0229	C:FXD ELECT 33 UF 10% 10VDCW	
A5C7	0180-0116	C:FXD ELECT 6.8 UF 10% 35VDCW	
A5C8	0160-2055	C:FXD CER 0.01 UF +80-20% 100VDCW	
A5C9	0180-1735	C:FXD ELECT 0.22 UF 10% 35VDCW	
A5C10	0160-2139	C:FXD CER 220 PF +80-20% 100VDCW	
A5C11	0160-2055	C:FXD CER 0.01 UF +80-20% 100VDCW	
A5C12	0180-1735	C:FXD ELECT 0.22 UF 10% 35VDCW	
A5C13	0160-3453	C:FXD CER 0.05 UF +80-20% 100VDCW	
A5C14	0160-2055	C:FXD CER 0.01 UF +80-20% 100VDCW	
A5CR1	1901-0025	DIODE:SILICON 100MA/1V	
A5CR2	1910-0016	DIODE:GERMANIUM 100MA/0.85V 60PIV	
A5CR3	1901-0025	DIODE:SILICON 100MA/1V	
A5CR4	1901-0025	DIODE:SILICON 100MA/1V	
A5J1	1250-1195	CONNECTOR:RF SUB-MINIATURE SERIES	
A5J2	1250-1195	CONNECTOR:RF SUB-MINIATURE SERIES	
A5L1	9100-1629	COIL/CHOKE 47.0 UH 5%	
A5L2	9100-1629	COIL/CHOKE 47.0 UH 5%	
A5L3	9100-1629	COIL/CHOKE 47.0 UH 5%	
A5L4	9100-1643	COIL/CHOKE 300 UH 5%	
A5L5	9100-1622	COIL/CHOKE 24.0 UH 5%	
A5Q1	1854-0071	Q:SI NPN(SELECTED FROM 2N3704)	
A5Q2	1854-0071	Q:SI NPN(SELECTED FROM 2N3704)	
A5Q3	1854-0071	Q:SI NPN(SELECTED FROM 2N3704)	
A5Q4	1854-0071	Q:SI NPN(SELECTED FROM 2N3704)	
A5Q5	1854-0071	Q:SI NPN(SELECTED FROM 2N3704)	
A5Q6	1854-0071	Q:SI NPN(SELECTED FROM 2N3704)	
A5Q7	1854-0071	Q:SI NPN(SELECTED FROM 2N3704)	
A5R1	0757-0438	R:FXD MET FLM 5.11K 1% 1/8W	
A5R2	0757-0438	R:FXD MET FLM 5.11K 1% 1/8W	
A5R3	0683-5135	R:FXD COMP 51K OHM 5% 1/4W	
A5R4	0698-3435	R:FXD MET FLM 38.3K OHM 1% 1/8W	
A5R5	0683-7525	R:FXD COMP 7500 OHM 5% 1/4W	

See introduction to this section for ordering information

Table 6-3. Parts Indexed by Reference Designation (Cont.)

Reference Designation	Part No.	Description #	Note
A5R6	0757-0438	R:FXD MET FLM 5.11K 1% 1/8W	
A5R7	0757-0416	R:FXD MET FLM 511 OHM 1% 1/8W	
A5R8	0698-0084	R:FXD MET FLM 2.15K 1% 1/8W	
A5R9	0757-0394	R:FXD MET FLM 51.1 OHM 1% 1/8W	
A5R10	0757-0416	R:FXD MET FLM 511 OHM 1% 1/8W	
A5R11	0698-3441	R:FXD MET FLM 215 OHM 1% 1/8W	
A5R12	0757-0438	R:FXD MET FLM 5.11K 1% 1/8W	
A5R13	0698-0084	R:FXD MET FLM 2.15K 1% 1/8W	
A5R14	0757-0420	R:FXD MET FLM 750 OHM 1% 1/8W	
A5R15	0683-1025	R:FXD COMP 1000 OHM 5% 1/4W	
A5R16	0698-3441	R:FXD MET FLM 215 OHM 1% 1/8W	
A5R17	0757-0438	R:FXD MET FLM 5.11K 1% 1/8W	
A5R18	0757-0159	R:FXD MET FLM 1000 OHM 1% 1/2W	
A5R19	0683-1025	R:FXD COMP 1000 OHM 5% 1/4W	
A5R20	0683-1025	R:FXD COMP 1000 OHM 5% 1/4W	
A5R21	0683-1025	R:FXD COMP 1000 OHM 5% 1/4W	
A5R22	0683-1025	R:FXD COMP 1000 OHM 5% 1/4W	
A5R23	0683-1025	R:FXD COMP 1000 OHM 5% 1/4W	
A5R24	0683-1025	R:FXD COMP 1000 OHM 5% 1/4W	
A5R25	0683-1025	R:FXD COMP 1000 OHM 5% 1/4W	
A5R26	0683-6225	R:FXD COMP 6200 OHM 5% 1/4W	
A5R27	0698-3441	R:FXD MET FLM 215 OHM 1% 1/8W	
A5R28	0757-1094	R:FXD MET FLM 1.47K OHM 1% 1/8W	
A5R29	0698-3441	R:FXD MET FLM 215 OHM 1% 1/8W	
A5S1	3101-1213	SWITCH:TOGGLE SUB-MINIATURE	
A5TP1	08443-00041	TEST POINT	
A5TP2	08443-00041	TEST POINT	
A5TP3	08443-00041	TEST POINT	
A5TP4	08443-00041	TEST POINT	
A5TP5	08443-00041	TEST POINT	
A5TP6	08443-00041	TEST POINT	
A5U1	1820-0054	IC:TTL QUAD 2-INPUT NAND GATE	
A5U2	1820-0304	IC:TTL J-K MASTER-SLAVE	
A5U3A	1820-0412	INTEGRATED CIRCUIT:DECADE DIVIDER	
A5U3B	1820-0412	INTEGRATED CIRCUIT:DECADE DIVIDER	
A5U4	1820-0412	INTEGRATED CIRCUIT:DECADE DIVIDER	
A5U5A	1820-0412	INTEGRATED CIRCUIT:DECADE DIVIDER	
A5U5B	1820-0412	INTEGRATED CIRCUIT:DECADE DIVIDER	
A6	08443-00047 08443-60105 08443-20034	BOARD ASSY:RF DECADE EXCHANGE HIGH FREQUENCY DECADE ASSY BOARD:BLANK PC	
A6C1	0160-2327	C:FXD CER 1000 PF 20% 100VDCW	
A6C2	0160-2327	C:FXD CER 1000 PF 20% 100VDCW	
A6C3	0180-0376	C:FXD ELECT 0.47 UF 10% 35VDCW	
A6C4	0180-0197	C:FXD ELECT 2.2 UF 10% 20VDCW	
A6C5	0160-2930	C:FXD CER 0.01 UF +80-20% 100VDCW	

See introduction to this section for ordering information

Table 6-3. Parts Indexed by Reference Designation (Cont.)

Reference Designation	Part No.	Description #	Note
A6C6	0160-2930	C:FXD CER 0.01 UF +80-20% 100VDCW	
A6C7	0160-2327	C:FXD CER 1000 PF 20% 100VDCW	
A6C8	0160-2327	C:FXD CER 1000 PF 20% 100VDCW	
A6C9	0180-0197	C:FXD ELECT 2.2 UF 10% 20VDCW	
A6C10	0180-0376	C:FXD ELECT 0.47 UF 10% 35VDCW	
A6C11	0180-0197	C:FXD ELECT 2.2 UF 10% 20VDCW	
A6C12	0180-0116	C:FXD ELECT 6.8 UF 10% 35VDCW	
A6C13	0160-2930	C:FXD CER 0.01 UF +80-20% 100VDCW	
A6C14	0160-2930	C:FXD CER 0.01 UF +80-20% 100VDCW	
A6C15	0160-2204	C:FXD MICA 100PF 5%	
A6C16	0160-2327	C:FXD CER 1000 PF 20% 100VDCW	
A6C17	0180-0376	C:FXD ELECT 0.47 UF 10% 35VDCW	
A6C18	0180-0197	C:FXD ELECT 2.2 UF 10% 20VDCW	
A6C19	0180-0376	C:FXD ELECT 0.47 UF 10% 35VDCW	
A6C20	0160-2930	C:FXD CER 0.01 UF +80-20% 100VDCW	
A6C21	0180-0197	C:FXD ELECT 2.2 UF 10% 20VDCW	
A6C22	0180-0376	C:FXD ELECT 0.47 UF 10% 35VDCW	
A6C23	0180-0197	C:FXD ELECT 2.2 UF 10% 20VDCW	
A6C24	0160-2327	C:FXD CER 1000 PF 20% 100VDCW	
A6C25	0180-0197	C:FXD ELECT 2.2 UF 10% 20VDCW	
A6C26	0160-2327	C:FXD CER 1000 PF 20% 100VDCW	
A6C27	0160-2327	C:FXD CER 1000 PF 20% 100VDCW	
A6C28	0160-2327	C:FXD CER 1000 PF 20% 100VDCW	
A6C29	0160-2327	C:FXD CER 1000 PF 20% 100VDCW	
A6C30	0180-0197	C:FXD ELECT 2.2 UF 10% 20VDCW	
A6C31	0160-2204	C:FXD MICA 100PF 5%	
A6CR1	1901-0047	DIODE JUNCTION:SILICON 20PIV	
A6CR2	1901-0047	DIODE JUNCTION:SILICON 20PIV	
A6CR3	1901-0518	DIODE:HOT CARRIER	
A6CR4	1901-0518	DIODE:HOT CARRIER	
A6CR5	1902-0518	DIODE BREAKDOWN:5.11V	
A6CR6	1901-0047	DIODE JUNCTION:SILICON 20PIV	
A6CR7	1901-0047	DIODE JUNCTION:SILICON 20PIV	
A6CR8	1901-0047	DIODE JUNCTION:SILICON 20PIV	
A6CR9	1902-3024	DIODE BREAKDOWN:2.87V 5%	
A6CR10	1901-0047	DIODE JUNCTION:SILICON 20PIV	
A6CR11	1901-0518	DIODE:HOT CARRIER	
A6CR12	1901-0025	DIODE:SILICON 100MA/1V	
A6CR13	1902-0048	DIODE:BREAKDOWN 6.81V 5%	
A6CR14	1902-0048	DIODE:BREAKDOWN 6.81V 5%	
A6CR15	1901-0179	DIODE:SILICON 15WV	
A6CR16	1901-0179	DIODE:SILICON 15WV	
A6CR17	1901-0039	DIODE:SILICON 200MA 50WV	
A6CR18	1901-0039	DIODE:SILICON 200MA 50WV	
A6J1	1250-1195	CONNECTOR:RF SUB-MINIATURE SERIES	

See introduction to this section for ordering information

Table 6-3. Parts Indexed by Reference Designation (Cont.)

Reference Designation	Part No.	Description #	Note
A6J2	1250-1195	CONNECTOR:RF SUB-MINIATURE SERIES	
A6J3	1250-1195	CONNECTOR:RF SUB-MINIATURE SERIES	
A6L1	9100-1616	COIL/CHOKE 1.50 UH 10%	
A6L2	9100-1616	COIL/CHOKE 1.50 UH 10%	
A6L3	9100-1630	COIL/CHOKE 51.0 UH 5%	
A6L4	9100-1623	COIL/CHOKE 27 UH 5%	
A6L5	9100-1616	COIL/CHOKE 1.50 UH 10%	
A6L6	9100-1616	COIL/CHOKE 1.50 UH 10%	
A6L7		NOT ASSIGNED	
A6L8	9100-1616	COIL/CHOKE 1.50 UH 10%	
A6L9	9100-1611	COIL:FXD 0.22 UH 20%	
A6L10	9100-1611	COIL:FXD 0.22 UH 20%	
A6L11	9100-1611	COIL:FXD 0.22 UH 20%	
A6Q1	1854-0345	Q:SI NPN	
A6Q2	1854-0345	Q:SI NPN	
A6Q3	1854-0071	Q:SI NPN(SELECTED FROM 2N3704)	
A6Q4	1853-0020	Q:SI PNP(SELECTED FROM 2N3702)	
A6Q5	1854-0019	Q:SI NPN(SELECTED FROM 2N2369)	
A6Q6	1854-0019	Q:SI NPN(SELECTED FROM 2N2369)	
A6Q7	1854-0019	Q:SI NPN(SELECTED FROM 2N2369)	
A6R1	0698-7229	R:FXD FLM 511 OHM 2% 1/8W	
A6R2	0757-0395	R:FXD MET FLM 56.2 OHM 1% 1/8W	
A6R3	0757-0442	R:FXD MET FLM 10.0K 1% 1/8W	
A6R4	0698-7229	R:FXD FLM 511 OHM 2% 1/8W	
A6R5	0757-0395	R:FXD MET FLM 56.2 OHM 1% 1/8W	
A6R6	0757-0442	R:FXD MET FLM 10.0K 1% 1/8W	
A6R7	0757-0438	R:FXD MET FLM 5.11K 1% 1/8W	
A6R8	0757-0438	R:FXD MET FLM 5.11K 1% 1/8W	
A6R9	0757-0438	R:FXD MET FLM 5.11K 1% 1/8W	
A6R10	0757-0438	R:FXD MET FLM 5.11K 1% 1/8W	
A6R11	0757-0280	R:FXD MET FLM 1K OHM 1% 1/8W	
A6R12	0757-0438	R:FXD MET FLM 5.11K 1% 1/8W	
A6R13	0698-3151	R:FXD MET FLM 2.87K OHM 1% 1/8W	
A6R14	0698-3151	R:FXD MET FLM 2.87K OHM 1% 1/8W	
A6R15	0698-0083	R:FXD MET FLM 1.96K OHM 1% 1/8W	
A6R16	0757-0405	R:FXD MET FLM 162 OHM 1% 1/8W	
A6R17	0698-3434	R:FXD MET FLM 34.8 OHM 1% 1/8W	
A6R18	0698-3444	R:FXD MET FLM 316 OHM 1% 1/8W	
A6R19	0698-0083	R:FXD MET FLM 1.96K OHM 1% 1/8W	
A6R20	0757-0279	R:FXD MET FLM 3.16K OHM 1% 1/8W	
A6R21	0757-0405	R:FXD MET FLM 162 OHM 1% 1/8W	
A6R22	0698-3434	R:FXD MET FLM 34.8 OHM 1% 1/8W	
A6R23	0757-0416	R:FXD MET FLM 511 OHM 1% 1/8W	
A6R24	0698-3435	R:FXD MET FLM 38.3 OHM 1% 1/8W	
A6R25	0757-0416	R:FXD MET FLM 511 OHM 1% 1/8W	

See introduction to this section for ordering information

Table 6-3. Parts Indexed by Reference Designation (Cont.)

Reference Designation	Part No.	Description #	Note
A6R26	0698-0083	R:FXD MET FLM 1.96K OHM 1% 1/8W	
A6R27	0757-1001	R:FXD MET FLM 56.2 OHM 1% 1/2W	
A6R28	0698-7236	R:FXD FLM 1K OHM 2% 1/8W	
A6R29	0698-7236	R:FXD FLM 1K OHM 2% 1/8W	
A6R30	0698-7236	R:FXD FLM 1K OHM 2% 1/8W	
A6R31	0757-0442	R:FXD MET FLM 10.0K 1% 1/8W	
A6R32	0698-0083	R:FXD MET FLM 1.96K OHM 1% 1/8W	
A6R33	0757-0274	R:FXD MET FLM 1.21K OHM 1% 1/8W	
A6TP1	08443-00041	TEST POINT	
A6TP2	08443-00041	TEST POINT	
A6TP3	08443-00041	TEST POINT	
A6TP4	08443-00041	TEST POINT	
A6TP5	08443-00041	TEST POINT	
A6TP6	08443-00041	TEST POINT	
A6U1	1820-0275	INTEGRATED CIRCUIT: DIGITAL	
A6U2	1820-0102	INTEGRATED CIRCUIT: J-K FLIP FLOP	
A6U3	1820-0101	INTEGRATED CIRCUIT: DIFFERENTIAL AMPL	
A6U4	1820-0102	INTEGRATED CIRCUIT: J-K FLIP FLOP	
A6U5	1820-0102	INTEGRATED CIRCUIT: J-K FLIP FLOP	
A6U6	1820-0102	INTEGRATED CIRCUIT: J-K FLIP FLOP	
A7	08443-60046 08443-60106 08443-20033	MARKER CONTROL ASSY EXCHANGE MARKER CONTROL ASSY BOARD: BLANK PC	
A7C1	0160-2055	C:FXD CER 0.01 UF +80-20% 100VDCW	
A7C2	0160-2055	C:FXD CER 0.01 UF +80-20% 100VDCW	
A7C3	0160-2055	C:FXD CER 0.01 UF +80-20% 100VDCW	
A7C4	0160-2055	C:FXD CER 0.01 UF +80-20% 100VDCW	
A7C5	0160-2257	C:FXD CER 10 PF 5% 500VDCW	
A7C6	0160-2055	C:FXD CER 0.01 UF +80-20% 100VDCW	
A7C7	0160-2055	C:FXD CER 0.01 UF +80-20% 100VDCW	
A7C8	0160-2055	C:FXD CER 0.01 UF +80-20% 100VDCW	
A7C9	0160-2055	C:FXD CER 0.01 UF +80-20% 100VDCW	
A7C10	0180-0197	C:FXD ELECT 2.2 UF 10% 20VDCW	
A7C11	0180-0197	C:FXD ELECT 2.2 UF 10% 20VDCW	
A7C12	0180-0197	C:FXD ELECT 2.2 UF 10% 20VDCW	
A7C13	0180-0098	C:FXD ELECT 100 UF 20% 20VDCW	
A7C14	0180-0116	C:FXD ELECT 6.8 UF 10% 35VDCW	
A7C15	0160-2139	C:FXD CER 220 PF +80-20% 1000VDCW	
A7C16	0160-2143	C:FXD CER 2000 PF +80-20% 1000VDCW	
A7C17	0180-0116	C:FXD ELECT 6.8 UF 10% 35VDCW	
A7C18	0180-0376	C:FXD ELECT 0.47 UF 10% 35VDCW	
A7C19	0160-2055	C:FXD CER 0.01 UF +80-20% 100VDCW	
A7CR1	1901-0025	DIODE: SILICON 100MA/1V	
A7CR2	1902-3268	DIODE BREAKDOWN: 26.1V 5%	
A7CR3	1901-0025	DIODE: SILICON 100MA/1V	
A7CR4	1901-0025	DIODE: SILICON 100MA/1V	
A7CR5	1901-0025	DIODE: SILICON 100MA/1V	

See introduction to this section for ordering information

Table 6-3. Parts Indexed by Reference Designation (Cont.)

Reference Designation	Part No.	Description #	Note
A7CR6	1901-0159	DIODE:SILICON 0.75A 400PIV	
A7CR7	1901-0025	DIODE:SILICON 100MA/1V	
A7CR8	1901-0025	DIODE:SILICON 100MA/1V	
A7CR9	1910-0016	DIODE:GERMANIUM 100MA/0.85V 60PIV	
A7CR10	1910-0016	DIODE:GERMANIUM 100MA/0.85V 60PIV	
A7CR11	1901-0025	DIODE:SILICON 100MA/1V	
A7CR12	1901-0025	DIODE:SILICON 100MA/1V	
A7CR13	1901-0025	DIODE:SILICON 100MA/1V	
A7CR14	1901-0025	DIODE:SILICON 100MA/1V	
A7CR15	1901-0025	DIODE:SILICON 100MA/1V	
A7CR16	1901-0025	DIODE:SILICON 100MA/1V	
A7CR17	1901-0025	DIODE:SILICON 100MA/1V	
A7CR18	1910-0016	DIODE:GERMANIUM 100MA/0.85V 60PIV	
A7CR19	1901-0025	DIODE:SILICON 100MA/1V	
A7CR20	1901-0025	DIODE:SILICON 100MA/1V	
A7CR21	1901-0025	DIODE:SILICON 100MA/1V	
A7CR22	1910-0016	DIODE:GERMANIUM 100MA/0.85V 60PIV	
A7J1	1250-1195	CONNECTOR:RF SUB-MINIATURE SERIES	
A7J2	1250-1195	CONNECTOR:RF SUB-MINIATURE SERIES	
A7L1	9140-0129	COIL:FXD RF 220 UH	
A7L2	9100-1629	COIL/CHOKE 47.0 UH 5%	
A7L3	9100-1629	COIL/CHOKE 47.0 UH 5%	
A7L4	9100-1629	COIL/CHOKE 47.0 UH 5%	
A7L5	9140-0129	COIL:FXD RF 220 UH	
A7L6	9140-0129	COIL:FXD RF 220 UH	
A7L7	9140-0129	COIL:FXD RF 220 UH	
A7Q1	1853-0020	Q:SI PNP(SELECTED FROM 2N3702)	
A7Q2	1853-0020	Q:SI PNP(SELECTED FROM 2N3702)	
A7Q3	1854-0071	Q:SI NPN(SELECTED FROM 2N3704)	
A7Q4	1854-0071	Q:SI NPN(SELECTED FROM 2N3704)	
A7Q5	1854-0221	Q:SI NPN(REPLACEABLE BY 2N4044)	
A7Q6	1854-0221	Q:SI NPN(REPLACEABLE BY 2N4044)	
A7Q7	1854-0071	Q:SI NPN(SELECTED FROM 2N3704)	
A7Q8	1854-0071	Q:SI NPN(SELECTED FROM 2N3704)	
A7Q9	1854-0071	Q:SI NPN(SELECTED FROM 2N3704)	
A7Q10	1853-0020	Q:SI PNP(SELECTED FROM 2N3702)	
A7Q11	1853-0020	Q:SI PNP(SELECTED FROM 2N3702)	
A7Q12	1854-0071	Q:SI NPN(SELECTED FROM 2N3704)	
A7Q13	1854-0071	Q:SI NPN(SELECTED FROM 2N3704)	
A7Q14	1854-0071	Q:SI NPN(SELECTED FROM 2N3704)	
A7Q15	1854-0071	Q:SI NPN(SELECTED FROM 2N3704)	
A7Q16	1854-0071	Q:SI NPN(SELECTED FROM 2N3704)	
A7Q17	1854-0071	Q:SI NPN(SELECTED FROM 2N3704)	
A7Q18	1854-0071	Q:SI NPN(SELECTED FROM 2N3704)	
A7Q19	1854-0071	Q:SI NPN(SELECTED FROM 2N3704)	
A7Q20	1853-0020	Q:SI PNP(SELECTED FROM 2N3702)	

See introduction to this section for ordering information

Table 6-3. Parts Indexed by Reference Designation (Cont.)

Reference Designation	Part No.	Description #	Note
A7R1	0757-0442	R:FXD MET FLM 10.0K 1% 1/8W	
A7R2	0757-0442	R:FXD MET FLM 10.0K 1% 1/8W	
A7R3	0757-0280	R:FXD MET FLM 1K OHM 1% 1/8W	
A7R4	0757-0438	R:FXD MET FLM 5.11K 1% 1/8W	
A7R5	0698-3155	R:FXD MET FLM 4.64K 1% 1/8W	
A7R6	0757-0442	R:FXD MET FLM 10.0K 1% 1/8W	
A7R7	0757-0438	R:FXD MET FLM 5.11K 1% 1/8W	
A7R8	0698-3155	R:FXD MET FLM 4.64K 1% 1/8W	
A7R9	0698-0084	R:FXD MET FLM 2.15K 1% 1/8W	
A7R10	0757-0442	R:FXD MET FLM 10.0K 1% 1/8W	
A7R11	2100-1758	R:VAR WW 1K OHM 5% TYPE V 1W	
A7R12	0698-0085	R:FXD MET FLM 2.61K OHM 1% 1/8W	
A7R13	0698-0085	R:FXD MET FLM 2.61K OHM 1% 1/8W	
A7R14	0757-0442	R:FXD MET FLM 10.0K 1% 1/8W	
A7R15	0757-0280	R:FXD MET FLM 1K OHM 1% 1/8W	
A7R16	0757-0442	R:FXD MET FLM 10.0K 1% 1/8W	
A7R17	0757-0442	R:FXD MET FLM 10.0K 1% 1/8W	
A7R18	0757-0458	R:FXD MET FLM 51.1K OHM 1% 1/8W	
A7R19	0757-0438	R:FXD MET FLM 5.11K 1% 1/8W	
A7R20	0757-0401	R:FXD MET FLM 100 OHM 1% 1/8W	
A7R21	0757-0199	R:FXD MET FLM 21.5K OHM 1% 1/8W	
A7R22	0757-0401	R:FXD MET FLM 100 OHM 1% 1/8W	
A7R23	0757-0458	R:FXD MET FLM 51.1K OHM 1% 1/8W	
A7R24	0757-0442	R:FXD MET FLM 10.0K 1% 1/8W	
A7R25	0757-0440	R:FXD MET FLM 7.50K 1% 1/8W	
A7R26	0757-0442	R:FXD MET FLM 10.0K 1% 1/8W	
A7R27	0757-0416	R:FXD MET FLM 511 OHM 1% 1/8W	
A7R28	0757-0458	R:FXD MET FLM 51.1K OHM 1% 1/8W	
A7R29	0698-3452	R:FXD MET FLM 147K OHM 1% 1/8W	
A7R30	0757-0280	R:FXD MET FLM 1K OHM 1% 1/8W	
A7R31	0698-3153	R:FXD MET FLM 3.83K 1% 1/8W	
A7R32	0698-3153	R:FXD MET FLM 3.83K 1% 1/8W	
A7R33	0757-0199	R:FXD MET FLM 21.5K OHM 1% 1/8W	
A7R34	0757-0279	R:FXD MET FLM 3.16K OHM 1% 1/8W	
A7R35	0757-0279	R:FXD MET FLM 3.16K OHM 1% 1/8W	
A7R36	0757-0199	R:FXD MET FLM 21.5K OHM 1% 1/8W	
A7R37	0757-0438	R:FXD MET FLM 5.11K 1% 1/8W	
A7R38	0757-0289	R:FXD MET FLM 13.3K OHM 1% 1/8W	
A7R39	0757-0401	R:FXD MET FLM 100 OHM 1% 1/8W	
A7R40	0698-3260	R:FXD MET FLM 464K OHM 1% 1/8W	
A7R41	0757-0442	R:FXD MET FLM 10.0K 1% 1/8W	
A7R42	0757-0199	R:FXD MET FLM 21.5K OHM 1% 1/8W	
A7R43	0757-0279	R:FXD MET FLM 3.16K OHM 1% 1/8W	
A7TP1	08443-00041	TEST POINT	
A7TP2	08443-00041	TEST POINT	
A7TP3	08443-00041	TEST POINT	
A7TP4	08443-00041	TEST POINT	
A7TP5	08443-00041	TEST POINT	

See introduction to this section for ordering information

Table 6-3. Parts Indexed by Reference Designation (Cont.)

Reference Designation	Part No.	Description #	Note
A7U1	1820-0054	IC:TTL QUAD 2-INPUT NAND GATE	
A7U2	1820-0304	IC:TTL J-K MASTER-SLAVE	
A8	08443-60045 08443-60108 08443-20026	VIDEO ASSY:AMPLIFIER ALC EXCHANGE ALC VIDEO AMPLIFIER ASSY BOARD:BLANK PC	
A8C1	0160-2145	C:FXD CER 5000 PF +80-20% 100VDCW	
A8C2	0160-2204	C:FXD MICA 100PF 5%	
A8C3	0180-1743	C:FXD ELECT 0.1 UF 10% 35VDCW	
A8C4	0160-2145	C:FXD CER 5000 PF +80-20% 100VDCW	
A8C5	0160-2145	C:FXD CER 5000 PF +80-20% 100VDCW	
A8C6	0160-2145	C:FXD CER 5000 PF +80-20% 100VDCW	
A8C7	0160-2145	C:FXD CER 5000 PF +80-20% 100VDCW	
A8L1	9100-1618	COIL:MULDED CHOKE 5.60 UH	
A8Q1	1854-0221	Q:SI NPN(REPLACEABLE BY 2N4044)	
A8Q2	1853-0020	Q:SI PNP(SELECTED FROM 2N3702)	
A8Q3	1854-0071	Q:SI NPN(SELECTED FROM 2N3704)	
A8Q4	1854-0071	Q:SI NPN(SELECTED FROM 2N3704)	
A8R1	0683-1135	R:FXD COMP 11K OHM 5% 1/4W	
A8R2	0683-1565	R:FXD COMP 15 MEGOHM 5% 1/4W	
A8R3	0683-1135	R:FXD COMP 11K OHM 5% 1/4W	
A8R4	0683-1045	R:FXD COMP 100K OHMS 5% 1/4W	
A8R5	0683-1315	R:FXD COMP 130 OHM 5% 1/4W	
A8R6	0683-1315	R:FXD COMP 130 OHM 5% 1/4W	
A8R7	0683-3035	R:FXD COMP 30K OHM 5% 1/4W	
A8R8	0683-1135	R:FXD COMP 11K OHM 5% 1/4W	
A8R9	0683-1025	R:FXD COMP 1000 OHM 5% 1/4W	
A8R10	0683-1135	R:FXD COMP 11K OHM 5% 1/4W	
A8R11	0683-1135	R:FXD COMP 11K OHM 5% 1/4W	
A8R12	0757-0459	R:FXD MET FLM 56.2K OHM 1% 1/8W	
A8R13	0757-0440	R:FXD MET FLM 7.50K 1% 1/8W	
A8R14	2100-2489	R:VAR FLM 5K OHM 10% LIN 1/2W	
A8R15	0683-1025	R:FXD COMP 1000 OHM 5% 1/4W	
A8R16	2100-2517	R:VAR FLM 50K OHM 10% LIN 1/2W	
A8R17	0683-1315	R:FXD COMP 130 OHM 5% 1/4W	
A8A1	08443-60022	BOARD ASSY:VIDEO AMPLIFIER	
	08443-20022	BOARD:BLANK PC	
A8A1C1	0160-3060	C:FXD CER 0.1 UF 20% 25VDCW	
A8A1C2	0160-3060	C:FXD CER 0.1 UF 20% 25VDCW	
A8A1C3	0180-0160	C:FXD ELECT 22 UF 20% 35VDCW	
A8A1C4	0160-3060	C:FXD CER 0.1 UF 20% 25VDCW	
A8A1C5	0160-3036	C:FXD CER 5000 PF +80-20% 200VDCW	

See introduction to this section for ordering information

Table 6-3. Parts Indexed by Reference Designation (Cont.)

Reference Designation	Part No.	Description #	Note
A8A1C6	0160-3036	C:FXD CER 5000 PF +80-20% 200VDCW	
A8A1J1	1251-1556	CONNECTOR:SINGLE CONTACT	
A8A1K1	0683-1005	R:FXD COMP 10 OHM 5% 1/4W	
A8A1K2	0683-1005	R:FXD COMP 10 OHM 5% 1/4W	
A8A1K3	0699-0001	R:FXD COMP 2.7 OHM 10% 1/2W	
A8A1K4	0757-0394	R:FXD MET FLM 51.1 OHM 1% 1/8W	
A8A1K5	0757-0421	R:FXD MET FLM 825 OHM 1% 1/8W	
A8A1K6	0698-7222	R:FXD FLM 261 OHM 2% 1/8W FACTORY SELECTED PART	
A8A1U1	1820-0267	INTEGRATED CIRCUIT:POWER AMPL.	
A8A1U2	1820-0403	INTEGRATED CIRCUIT:PRE-AMP	
A9	08443-60044 08443-60108 08443-20023	CONVERTER ASSY:THIRD EXCHANGE THIRD CONVERTER ASSY BOARD:BLANK PC	
A9C1	0150-0050	C:FXD CER 1000 PF +80-20% 1000VDCW	
A9C2	0160-2140	C:FXD CER 470 PF +80-20% 1000VDCW	
A9C3	0160-2139	C:FXD CER 220 PF +80-20% 1000VDCW	
A9C4	0160-2139	C:FXD CER 220 PF +80-20% 1000VDCW	
A9C5	0160-3425	C:FXD CER 33 PF 5% 500VDCW	
A9C6	0160-2139	C:FXD CER 220 PF +80-20% 1000VDCW	
A9C7	0160-2139	C:FXD CER 220 PF +80-20% 1000VDCW	
A9C8	0160-2139	C:FXD CER 220 PF +80-20% 1000VDCW	
A9C9	0160-2260	C:FXD CER 13 PF 5% 500VDCW	
A9C10	0160-2139	C:FXD CER 220 PF +80-20% 1000VDCW	
A9C11	0160-2139	C:FXD CER 220 PF +80-20% 1000VDCW	
A9C12	0160-2139	C:FXD CER 220 PF +80-20% 1000VDCW	
A9C13	0160-2140	C:FXD CER 470 PF +80-20% 1000VDCW	
A9L1	9140-0158	COIL:FXD RF 1 UH 10%	
A9L2	9100-2248	COIL/CHOKE 0.12 UH 10%	
A9L3	9140-0158	COIL:FXD RF 1 UH 10%	
A9L4	9100-2247	COIL:FXD RF 0.10 UH 10%	
A9L5	9140-0158	COIL:FXD RF 1 UH 10%	
A9Q1	1854-0247	Q:SI NPN	
A9Q2	1854-0345	Q:SI NPN	
A9Q3	1854-0345	Q:SI NPN	
A9R1	0757-0398	R:FXD MET FLM 75 OHM 1% 1/8W	
A9R2	0757-0403	R:FXD MET FLM 121 OHM 1% 1/8W	
A9R3	0757-0398	R:FXD MET FLM 75 OHM 1% 1/8W	
A9R4	0757-0428	R:FXD MET FLM 1.62K 1% 1/8W	
A9R5	0698-0084	R:FXD MET FLM 2.15K 1% 1/8W	
A9R6	0757-0346	R:FXD MET FLM 10 OHM 1% 1/8W	
A9R7	0757-0416	R:FXD MET FLM 511 OHM 1% 1/8W	
A9R8	0698-3444	R:FXD MET FLM 316 OHM 1% 1/8W	
A9R9	0698-3431	R:FXD MET FLM 23.7 OHM 1% 1/8W	
A9R10	0757-0416	R:FXD MET FLM 511 OHM 1% 1/8W	

See introduction to this section for ordering information

Table 6-3. Parts Indexed by Reference Designation (Cont.)

Reference Designation	Part No.	Description #	Note
A9R11	0698-3444	R:FXD MET FLM 316 OHM 1% 1/8W	
A9R12	0757-0419	R:FXD MET FLM 681 OHM 1% 1/8W	
A9R13	0757-0422	R:FXD MET FLM 909 OHM 1% 1/8W	
A9R14	0698-3429	R:FXD MET FLM 19.6 OHM 1% 1/8W	
A9R15	0757-1060	R:FXD MET FLM 196 OHM 1% 1/2W	
A9R16	0757-0416	R:FXD MET FLM 511 OHM 1% 1/8W	
A9T1	08552-6018	TRANSFORMER:RF(CODE=RED)	
A9T2	08552-6018	TRANSFORMER:RF(CODE=RED)	
A9A1	08443-60005	MIXER ASSY:THIRD	
	08443-20024	BOARD:BLANK PC	
A9A1CR1	10514-8454	DIODE:SILICON MATCHED QUAD	
A9A1CR2		PART OF A9A1CR1	
A9A1CR3		PART OF A9A1CR1	
A9A1CR4		PART OF A9A1CR1	
A9A1R1	0698-3435	R:FXD MET FLM 38.3 OHM 1% 1/8W	
A9A1R2	0698-3438	R:FXD MET FLM 147 OHM 1% 1/8W	
A9A1R3	0698-3438	R:FXD MET FLM 147 OHM 1% 1/8W	
A9A1T1	08552-6024	TRANSFORMER:RF(CODE=YELLOW)	
A9A1T2	08553-6012	TRANSFORMER:RF(CODE=BLUE)	
A9A1T3	08553-6012	TRANSFORMER:RF(CODE=BLUE)	
A9A1T4	08552-6024	TRANSFORMER:RF(CODE=YELLOW)	
A9A2	08443-60006	FILTER ASSY:120 MHZ	

See introduction to this section for ordering information

Table 6-3. Parts Indexed by Reference Designation (Cont.)

Reference Designation	Part No.	Description #	Note
	08443-20025	BOARD: BLANK PC	
A9A2C1	0160-2013	C:FXD MICA 39 PF 5%	
A9A2C2	0160-2016	C:FXD MICA 62 PF 5% 500VDCW	
A9A2C3	0160-0949	C:FXD MICA 68 PF 5%	
A9A2C4	0160-2016	C:FXD MICA 62 PF 5% 500VDCW	
A9A2C5	0160-2013	C:FXD MICA 39 PF 5%	
A9A2L1	08553-6018	INDUCTOR ASSY:AIR CORE	
A9A2L2	9100-2247	COIL:FXD RF 0.10 UH 10%	
A9A2L3	9100-2247	COIL:FXD RF 0.10 UH 10%	
A9A2L4	9100-2247	COIL:FXD RF 0.10 UH 10%	
A9A2L5	9100-2247	COIL:FXD RF 0.10 UH 10%	
A9A2L6	08553-6018	INDUCTOR ASSY:AIR CORE	
A10	08443-60043 08443-60109 08443-20021	IF ASSY:200 MHZ EXCHANGE IF AMPLIFIER ASSY(200 MHZ) BOARD: BLANK PC	
A10C1	0160-2204	C:FXD MICA 100PF 5%	
A10C2	0160-2140	C:FXD CER 470 PF +80-20% 1000VDCW	
A10C3	0160-2140	C:FXD CER 470 PF +80-20% 1000VDCW	
A10C4	0121-0446	C:VAR CER 4.5-20 PF 160VDCW N750	
A10C5	0121-0105	C:VAR CER 9-35 PF NPO	
A10C6	0160-2140	C:FXD CER 470 PF +80-20% 1000VDCW	
A10C7	0150-0050	C:FXD CER DISC 1000 PF +80-20% 1000VDCW	
A10C8	0160-2140	C:FXD CER 470 PF +80-20% 1000VDCW	
A10C9	0160-2140	C:FXD CER 470 PF +80-20% 1000VDCW	
A10C10	0122-0285	C:VOLTAGE VAR 6.8 PF 5%	
A10C11	0160-2140	C:FXD CER 470 PF +80-20% 1000VDCW	
A10C12	0150-0050	C:FXD CER DISC 1000 PF +80-20% 1000VDCW	
A10C13	0150-0050	C:FXD CER DISC 1000 PF +80-20% 1000VDCW	
A10C14	0150-0050	C:FXD CER DISC 1000 PF +80-20% 1000VDCW	
A10C15	0160-2140	C:FXD CER 470 PF +80-20% 1000VDCW	
A10C16	0160-2145	C:FXD CER 5000 PF +80-20% 100VDCW	
A10C17	0160-2247	C:FXD CER 3.9 PF 5%	
A10CR1	1902-3104	DIODE BREAKDOWN:5.62V 5%	
A10CR2	1902-3104	DIODE BREAKDOWN:5.62V 5%	
A10J1	1250-0835	CONNECTOR:RF PC MOUNT	
A10L1	9100-1611	COIL:FXD 0.22 UH 20%	
A10L2	9100-1610	COIL:MOLDED CHOKE 0.15 UH 20%	
A10L3	9100-1610	COIL:MOLDED CHOKE 0.15 UH 20%	
A10L4	9140-0141	COIL:FXD RF 0.68 UH	
A10L5	9140-0158	COIL:FXD RF 1 UH 10%	
A10L6	9100-3101	COIL:VAR 0.142 TO 0.158 UH	
A10L7	9100-1612	COIL:FXD RF 0.33 UH 20%	
A10L8	9140-0141	COIL:FXD RF 0.68 UH	
A10L9	9140-0158	COIL:FXD RF 1 UH 10%	
A10L10	9140-0158	COIL:FXD RF 1 UH 10%	
A10Q1	1854-0345	Q:SI NPN	

See introduction to this section for ordering information

Table 6-3. Parts Indexed by Reference Designation (Cont.)

Reference Designation	Part No.	Description #	Note
A1002	1854-0345	Q:SI NPN	
A10R1	0698-3441	R:FXD MET FLM 215 OHM 1% 1/8W	
A10R2	0757-0346	R:FXD MET FLM 10 OHM 1% 1/8W	
A10R3	0757-0417	R:FXD MET FLM 562 OHM 1% 1/8W	
A10R4	0683-3025	R:FXD COMP 3000 OHM 5% 1/4W	
A10R5	0698-3441	R:FXD MET FLM 215 OHM 1% 1/8W	
A10R6	0757-0346	R:FXD MET FLM 10 OHM 1% 1/8W	
A10R7	0757-0417	R:FXD MET FLM 562 OHM 1% 1/8W	
A10TP1	08443-00041	TEST POINT	
A10A1	08443-60007	FILTER ASSY:200 MHZ	
A11	08443-60042 08443-60110 08443-20020	CONVERTER ASSY:SECOND EXCHANGE SECOND CONVERTER ASSY BOARD:BLANK PC	
A11C1	0160-2145	C:FXD CER 5000 PF +80-20% 100VDCW	
A11C2	0150-0050	C:FXD CER DISC 1000 PF +80-20% 1000VDCW	
A11C3	0150-0050	C:FXD CER DISC 1000 PF +80-20% 1000VDCW	
A11C4	0150-0050	C:FXD CER DISC 1000 PF +80-20% 1000VDCW	
A11C5	0150-0050	C:FXD CER DISC 1000 PF +80-20% 1000VDCW	
A11C6	0150-0050	C:FXD CER DISC 1000 PF +80-20% 1000VDCW	
A11C7	0150-0050	C:FXD CER DISC 1000 PF +80-20% 1000VDCW	
A11C8	0150-0050	C:FXD CER DISC 1000 PF +80-20% 1000VDCW	
A11C9	0150-0050	C:FXD CER DISC 1000 PF +80-20% 1000VDCW	
A11C10	0150-0050	C:FXD CER DISC 1000 PF +80-20% 1000VDCW	
A11C11	0150-0050	C:FXD CER DISC 1000 PF +80-20% 1000VDCW	
A11CR1	1902-3139	DIODE:BREAKDOWN 8.25V 5%	
A11CK2	10514-8454	DIODE:SILICON MATCHED QUAD	
A11CK3		PART OF CR2	
A11CK4		PART OF CR2	
A11CK5		PART OF CR2	
A11J1	1250-1195	CONNECTOR:RF SUB-MINIATURE SERIES	
A11J2	1250-1195	CONNECTOR:KF SUB-MINIATURE SERIES	
A11L1	9140-0144	COIL:FXD RF 4.7 UH	
A11L2	9100-1612	COIL:FXD KF 0.33 UH 20%	
A11Q1	1854-0345	Q:SI NPN	
A11Q2	1853-0018	Q:SI PNP(SELECTED FROM 2N4260)	
A11Q3	1854-0247	Q:SI NPN	
A11R1	0757-0279	R:FXD MET FLM 3.16K OHM 1% 1/8W	

See introduction to this section for ordering information

Table 6-3. Parts Indexed by Reference Designation (Cont.)

Reference Designation	Part No.	Description #	Note
A11R2	0757-0397	R:FXD MET FLM 68.1 OHM 1% 1/8W	
A11R3	0757-0417	R:FXD MET FLM 562 OHM 1% 1/8W	
A11R4	0757-0276	R:FXD MET FLM 61.9 OHM 1% 1/8W	
A11R5	0698-3428	R:FXD MET FLM 14.7 OHM 1% 1/8W	
A11R6	0757-0420	R:FXD MET FLM 750 OHM 1% 1/8W	
A11R7	0698-3443	R:FXD MET FLM 287 OHM 1% 1/8W	
A11R8	0698-3428	R:FXD MET FLM 14.7 OHM 1% 1/8W	
A11R9	0757-0276	R:FXD MET FLM 61.9 OHM 1% 1/8W	
A11R10	0757-0815	R:FXD MET FLM 562 OHM 1% 1/2W	
A11R11	0698-3334	R:FXD MET FLM 178 OHM 1% 1/2W	
A11R12	0698-3429	R:FXD MET FLM 19.6 OHM 1% 1/8W	
A11R13	0698-3401	R:FXD MET FLM 215 OHM 1% 1/2W	
A11R14		NOT ASSIGNED	
A11R15	0757-0394	R:FXD MET FLM 51.1 OHM 1% 1/8W	
A11R16	0757-0394	R:FXD MET FLM 51.1 OHM 1% 1/8W	
A11R17	0757-0394	R:FXD MET FLM 51.1 OHM 1% 1/8W	
A11R18	0757-0394	R:FXD MET FLM 51.1 OHM 1% 1/8W	
A11R19	0757-0401	R:FXD MET FLM 100 OHM 1% 1/8W	
A11R20	0757-0398	R:FXD MET FLM 75 OHM 1% 1/8W	
A11R21	0757-0401	R:FXD MET FLM 100 OHM 1% 1/8W	
A11T1	08552-6024	TRANSFORMER:RF(CODE=YELLOW)	
A11T2	08553-6012	TRANSFORMER:RF(CODE=BLUE)	
A11T3	08553-6012	TRANSFORMER:RF(CODE=BLUE)	
A11T4	08552-6024	TRANSFORMER:RF(CODE=YELLOW)	
A12	08443-60041 08443-60111 08443-20018	IF ASSY:50 MHZ EXCHANGE IF AMPLIFIER ASSY(50 MHZ) BOARD:BLANK PC	
A12C1	0160-2145	C:FXD CER 5000 PF +80-20% 100VDCW	
A12C2	0150-0050	C:FXD CER DISC 1000 PF +80-20% 1000VDCW	
A12C3	0150-0050	C:FXD CER DISC 1000 PF +80-20% 1000VDCW	
A12C4	0160-2142	C:FXD CER 1500 PF +100-0% 500VDCW	
A12C5	0150-0050	C:FXD CER DISC 1000 PF +80-20% 1000VDCW	
A12C6	0160-2254	C:FXD CER 7.5-0.25 PF 500VDCW	
A12C7	0160-2307	C:FXD MICA 47 PF 5%	
A12C8	0121-0059	C:VAR CER 2-8 PF 300VDCW	
A12C9	0160-2254	C:FXD CER 7.5-0.25 PF 500VDCW	
A12C10	0121-0059	C:VAR CER 2-8 PF 300VDCW	
A12C11	0150-0050	C:FXD CER DISC 1000 PF +80-20% 1000VDCW	
A12C12	0150-0050	C:FXD CER DISC 1000 PF +80-20% 1000VDCW	
A12C13	0150-0050	C:FXD CER DISC 1000 PF +80-20% 1000VDCW	
A12C14	0160-2201	C:FXD MICA 51 PF 5%	
A12C15	0160-2254	C:FXD CER 7.5-0.25 PF 500VDCW	
A12C16		NOT ASSIGNED	
A12C17	0121-0059	C:VAR CER 2-8 PF 300VDCW	
A12L1	9140-0158	COIL:FXD RF 1 UH 10%	
A12L2	9100-0346	COIL:FXD 0.05 UH 20%	
A12L3	9140-0096	COIL:FXD RF 1 UH	
A12L4	9140-0096	COIL:FXD RF 1 UH	
A12L5	9140-0096	COIL:FXD RF 1 UH	

See introduction to this section for ordering information

Table 6-3. Parts Indexed by Reference Designation (Cont.)

Reference Designation	Part No.	Description #	Note
A12L6	9140-0096	COIL:FXD RF 1 UH	
A12L7	9140-0114	COIL:FXD RF 10 UH	
A12Q1	1853-0089	Q:SI PNP	
A12Q2	1854-0247	Q:SI NPN	
A12R1	0698-3155	R:FXD MET FLM 4.64K 1/8W	
A12R2	0757-0438	R:FXD MET FLM 5.11K 1/8W	
A12R3	0757-0420	R:FXD MET FLM 750 OHM 1/8W	
A12R4	0757-0159	R:FXD MET FLM 1000 OHM 1/2W	
A12R5	0698-3429	R:FXD MET FLM 19.6 OHM 1/8W	
A12R6	0698-3441	R:FXD MET FLM 215 OHM 1/8W	
A12R7	0757-1092	R:FXD MET FLM 287 OHM 1/2W	
A12R8	0698-3437	R:FXD MET FLM 133 OHM 1/8W	
A12R9	0698-3433	R:FXD MET FLM 28.7 OHM 1/8W	
A12R10	0757-0180	R:FXD MET FLM 31.6 OHM 1/8W	
A12T1	08552-6018	TRANSFORMER:RF(CODE=RED)	
A12T2	08552-6018	TRANSFORMER:RF(CODE=RED)	
A12A1	08443-60004	FILTER ASSY:50 MHZ	
	08443-20019	BOARD:BLANK PC	
A12A1C1	0160-0778	C:FXD CER 56 PF 10% 500VDCW	
A12A1C2		NOT ASSIGNED	
A12A1C3	0160-0145	C:FXD MICA 82PF 2% 100VDCW	
A12A1C4	0160-2258	C:FXD CER 11 PF 5% 500VDCW	
A12A1C5	0121-0036	C:VAR CER 5.5-18 PF	
A12A1C6	0121-0036	C:VAR CER 5.5-18 PF	
A12A1C7	0160-2258	C:FXD CER 11 PF 5% 500VDCW	
A12A1C8	0160-2258	C:FXD CER 11 PF 5% 500VDCW	
A12A1C9	0121-0036	C:VAR CER 5.5-18 PF	
A12A1C10	0121-0036	C:VAR CER 5.5-18 PF	
A12A1C11	0160-2258	C:FXD CER 11 PF 5% 500VDCW	
A12A1C12	0160-2362	C:FXD MICA 140 PF 2% 300VDCW	
A12A1FL1	08443-60019	BOARD ASSY:50 MHZ FILTER	
A12A1L1	08552-6023	INDUCTOR ASSY:AIR CORE	
A12A1L2	08552-6017	INDUCTOR ASSY:50 MHZ	
A13	08443-60040	CONVERTER ASSY:FIRST	
	08443-60112	EXCHANGE FIRST CONVERTER ASSY	
	08443-20017	BOARD:BLANK PC	
A13C1	0160-2145	C:FXD CER 5000 PF +80-20% 100VDCW	
A13C2	0150-0050	C:FXD CER DISC 1000 PF +80-20% 100VDCW	
A13C3	0160-2145	C:FXD CER 5000 PF +80-20% 100VDCW	
A13C4	0150-0050	C:FXD CER DISC 1000 PF +80-20% 100VDCW	
A13C5	0150-0050	C:FXD CER DISC 1000 PF +80-20% 100VDCW	

See introduction to this section for ordering information

Table 6-3. Parts Indexed by Reference Designation (Cont.)

Reference Designation	Part No.	Description #	Note
A13C6	0150-0096	C:FXD CER 0.05 UF +80-20% 100VDCW	
A13C7	0150-0096	C:FXD CER 0.05 UF +80-20% 100VDCW	
A13C8	0150-0050	C:FXD CER DISC 1000 PF +80-20% 1000VDCW	
A13C9	0150-0096	C:FXD CER 0.05 UF +80-20% 100VDCW	
A13C10	0160-2229	C:FXD MICA 3000 PF 5%	
A13C11	0160-0157	C:FXD MY 0.0047 UF 10% 200VDCW	
A13C12	0150-0050	C:FXD CER DISC 1000 PF +80-20% 1000VDCW	
A13C13	0150-0050	C:FXD CER DISC 1000 PF +80-20% 1000VDCW	
A13C14	0150-0050	C:FXD CER DISC 1000 PF +80-20% 1000VDCW	
A13C15	0122-0049	DIODE TUNING:90 PF 10%	
A13C16		NOT ASSIGNED	
A13C17	0150-0050	C:FXD CER DISC 1000 PF +80-20% 1000VDCW	
A13C18	0150-0096	C:FXD CER 0.05 UF +80-20% 100VDCW	
A13C19	0160-2145	C:FXD CER 5000 PF +80-20% 100VDCW	
A13C20	0160-2145	C:FXD CER 5000 PF +80-20% 100VDCW	
A13CR1	1902-3139	DIODE: BREAKDOWN 8.25V 5%	
A13CR2	1901-0050	DIODE: SILICON 75V	
A13CR3	1901-0050	DIODE: SILICON 75V	
A13CR4	1901-0050	DIODE: SILICON 75V	
A13CR5	1901-0050	DIODE: SILICON 75V	
A13J1	1250-1195	CONNECTOR: RF SUB-MINIATURE SERIES	
A13J2	1250-1195	CONNECTOR: RF SUB-MINIATURE SERIES	
A13L1	9100-3102	COIL: VAR 1.42 TO 1.58 UH	
A13L2	9100-3103	COIL: VAR 42.0 TO 51.5 UH	
A13L3	9100-1612	COIL: FXD RF 0.33 UH 20%	
A13L4	9140-0144	COIL: FXD RF 4.7 UH	
A13L5	9140-0144	COIL: FXD RF 4.7 UH	
A13Q1	1854-0019	Q: SI NPN (SELECTED FROM 2N2369)	
A13Q2	1853-0034	Q: SI PNP (SELECTED FROM 2N3251)	
A13Q3	1853-0020	Q: SI PNP (SELECTED FROM 2N3702)	
A13Q4	1854-0023	Q: SI NPN (SELECTED FROM 2N2484)	
A13R1	0757-0279	R: FXD MET FLM 3.16K OHM 1% 1/8W	
A13R2	0757-0397	R: FXD MET FLM 68.1 OHM 1% 1/8W	
A13R3	0757-0416	R: FXD MET FLM 511 OHM 1% 1/8W	
A13R4	0757-0416	R: FXD MET FLM 511 OHM 1% 1/8W	
A13R5	0757-0417	R: FXD MET FLM 562 OHM 1% 1/8W	
A13R6	0757-0276	R: FXD MET FLM 61.9 OHM 1% 1/8W	
A13R7	0698-3429	R: FXD MET FLM 19.6 OHM 1% 1/8W	
A13R8	0757-0420	R: FXD MET FLM 750 OHM 1% 1/8W	
A13R9	0757-0288	R: FXD MET FLM 90.09K OHM 1% 1/8W	
A13R10	0683-1045	R: FXD COMP 100K OHMS 5% 1/4W	
A13R11	0698-3443	R: FXD MET FLM 287 OHM 1% 1/8W	
A13R12	0698-3431	R: FXD MET FLM 23.7 OHM 1% 1/8W	
A13R13	0757-0815	R: FXD MET FLM 562 OHM 1% 1/2W	
A13R14	0698-0082	R: FXD MET FLM 464 OHM 1% 1/8W	
A13R15	0757-0401	R: FXD MET FLM 100 OHM 1% 1/8W	

See introduction to this section for ordering information

Table 6-3. Parts Indexed by Reference Designation (Cont.)

Reference Designation	Part No.	Description #	Note
A13R16	0757-0438	R:FXD MET FLM 5.11K 1% 1/8W	
A13R17	0683-1005	R:FXD COMP 10 OHM 5% 1/4W	
A13R18	0698-0085	R:FXD MET FLM 2.61K OHM 1% 1/8W	
A13R19	0757-0288	R:FXD MET FLM 9.09K OHM 1% 1/8W	
A13R20	0757-0280	R:FXD MET FLM 1K OHM 1% 1/8W	
A13T1	08443-80001	TRANSFORMER:RF	
A13T2	08443-80001	TRANSFORMER:RF	
A13TP1	08443-00041	TEST POINT	
A13Y1	0410-0196	CRYSTAL:QUARTZ	
	1200-0770	SOCKET:CRYSTAL	
A14	08443-60015 08443-60113	BOARD ASSY:SENSE AMPLIFIER EXCHANGE SENSE AMPLIFIER ASSY	
A14C1	0160-0163	C:FXD MY 0.033 UF 10% 200VDCW	
A14C2	0180-0116	C:FXD ELECT 6.8 UF 10% 35VDCW	
A14C3	0180-1743	C:FXD ELECT 0.1 UF 10% 35VDCW	
A14C4	0180-1743	C:FXD ELECT 0.1 UF 10% 35VDCW	
A14C5	0180-1743	C:FXD ELECT 0.1 UF 10% 35VDCW	
A14C6	0180-0291	C:FXD ELECT 1.0 UF 10% 35VDCW	
A14C7	0180-0291	C:FXD ELECT 1.0 UF 10% 35VDCW	
A14C8	0160-2208	C:FXD MICA 330 PF 5% 300VDCW	
A14C9	0180-1747	C:FXD ELECT 150 UF 20% 15VDCW	
A14C10	0180-0291	C:FXD ELECT 1.0 UF 10% 35VDCW	
A14CR1	1901-0200	DIODE:SILICON 100 PIV 3A	
A14CR2	1902-0049	DIODE:BREAKDOWN 6.19V 5%	
A14CR3	1902-3193	DIODE BREAKDOWN:13.3V 5%	
A14CR4	1884-0012	RECTIFIER:SILICON CONTROLLED 2N3528	
A14CR5	1902-0033	DIODE:BREAKDOWN 6.2V	
A14CR6	1901-0025	DIODE:SILICON 100MA/1V	
A14CR7	1901-0025	DIODE:SILICON 100MA/1V	
A14CR8	1901-0025	DIODE:SILICON 100MA/1V	
A14CR9	1901-0025	DIODE:SILICON 100MA/1V	
A14CR10	1901-0200	DIODE:SILICON 100 PIV 3A	
A14CR11	1884-0012	RECTIFIER:SILICON CONTROLLED 2N3528	
A14CR12	1901-0200	DIODE:SILICON 100 PIV 3A	
A14CR13	1901-0200	DIODE:SILICON 100 PIV 3A	
A14CR14	1901-0200	DIODE:SILICON 100 PIV 3A	
A14CR15	1901-0200	DIODE:SILICON 100 PIV 3A	
A14CR16	1901-0200	DIODE:SILICON 100 PIV 3A	
A14CR17	1902-3268	DIODE BREAKDOWN:26.1V 5%	
A14CR18	1902-3256	DIODE:BREAKDOWN SILICON 23.7V 5%	
A14CR19	1902-0048	DIODE:BREAKDOWN 6.81V 5%	
A14G1	1854-0039	Q:SI NPN	

See introduction to this section for ordering information

Table 6-3. Parts Indexed by Reference Designation (Cont.)

Reference Designation	Part No.	Description #	Note
A1402	1854-0039	Q:SI NPN	
A1403	1854-0039	Q:SI NPN	
A1404	1853-0020	Q:SI PNP(SELECTED FROM 2N3702)	
A1405	1854-0071	Q:SI NPN(SELECTED FROM 2N3704)	
A1406	1854-0071	Q:SI NPN(SELECTED FROM 2N3704)	
A1407	1854-0071	Q:SI NPN(SELECTED FROM 2N3704)	
A1408	1854-0071	Q:SI NPN(SELECTED FROM 2N3704)	
A1409	1854-0071	Q:SI NPN(SELECTED FROM 2N3704)	
A14010	1854-0071	Q:SI NPN(SELECTED FROM 2N3704)	
A14011	1854-0071	Q:SI NPN(SELECTED FROM 2N3704)	
A14012	1854-0071	Q:SI NPN(SELECTED FROM 2N3704)	
A14013	1854-0071	Q:SI NPN(SELECTED FROM 2N3704)	
A14014	1854-0071	Q:SI NPN(SELECTED FROM 2N3704)	
A14015	1854-0039	Q:SI NPN	
A14016	1854-0071	Q:SI NPN(SELECTED FROM 2N3704)	
A14017	1854-0221	Q:SI NPN(REPLACEABLE BY 2N4044)	
A14018	1854-0071	Q:SI NPN(SELECTED FROM 2N3704)	
A14019	1854-0071	Q:SI NPN(SELECTED FROM 2N3704)	
A14R1	0683-5115	R:FXD COMP 510 OHM 5% 1/4W	
A14R2	0757-0199	R:FXD MET FLM 21.5K OHM 1% 1/8W	
A14R3	0683-0275	R:FXD COMP 2.7 OHM 5% 1/4W	
A14R4	0683-1015	R:FXD COMP 100 OHM 5% 1/4W	
A14R5	0683-5115	R:FXD COMP 510 OHM 5% 1/4W	
A14R6	0683-1635	R:FXD COMP 16K OHM 5% 1/4W	
A14R7	0683-1615	R:FXD COMP 100 OHM 5% 1/4W	
A14R8	0757-0420	R:FXD MET FLM 750 OHM 1% 1/8W	
A14R9	0683-5125	R:FXD COMP 5100 OHM 5% 1/4W	
A14R10	0683-1015	R:FXD COMP 100 OHM 5% 1/4W	
A14R11	0683-5115	R:FXD COMP 510 OHM 5% 1/4W	
A14R12	0757-0442	R:FXD MET FLM 10.0K 1% 1/8W	
A14R13	0698-0084	R:FXD MET FLM 2.15K 1% 1/8W	
A14R14	0698-0084	R:FXD MET FLM 2.15K 1% 1/8W	
A14R15	0683-5115	R:FXD COMP 510 OHM 5% 1/4W	
A14R16	0683-6205	R:FXD COMP 62 OHM 5% 1/4W	
A14R17	0683-1015	R:FXD COMP 100 OHM 5% 1/4W	
A14R18	0757-0428	R:FXD MET FLM 1.62K 1% 1/8W	
A14R19	0698-3409	R:FXD MET FLM 2.37K OHM 1% 1/2W	
A14R20	0683-1125	R:FXD COMP 1100 OHM 5% 1/4W	
A14R21	0698-0084	R:FXD MET FLM 2.15K 1% 1/8W	
A14R22	0683-0275	R:FXD COMP 2.7 OHM 5% 1/4W	
A14R23	0698-3159	R:FXD MET FLM 26.1K OHM 1% 1/8W	
A14R24	0698-3151	R:FXD MET FLM 2.87K OHM 1% 1/8W	
A14R25	0683-0275	R:FXD COMP 2.7 OHM 5% 1/4W	
A14R26	0698-3153	R:FXD MET FLM 3.83K 1% 1/8W	
A14R27	0698-3153	R:FXD MET FLM 3.83K 1% 1/8W	
A14R28	0757-0199	R:FXD MET FLM 21.5K OHM 1% 1/8W	
A14R29	0683-6235	R:FXD COMP 62K OHM 5% 1/4W	
A14R30	0683-5125	R:FXD COMP 5100 OHM 5% 1/4W	

See introduction to this section for ordering information

Table 6-3. Parts Indexed by Reference Designation (Cont.)

Reference Designation	Part No.	Description #	Note
A14R31	0683-1635	R:FXD COMP 16K OHM 5% 1/4W	
A14R32	0757-0821	R:FXD MET FLM 1.21K OHM 1% 1/2W	
A14R33	0757-0418	R:FXD MET FLM 619 OHM 1% 1/8W FACTORY SELECTED PART	
A14R34	0698-3150	R:FXD MET FLM 2.37K OHM 1% 1/8W	
A14R35	0698-3155	R:FXD MET FLM 4.64K 1% 1/8W	
A14R36	0757-0442	R:FXD MET FLM 10.0K 1% 1/8W	
A14R37	0683-5125	R:FXD COMP 5100 OHM 5% 1/4W	
A14R38	0698-0084	R:FXD MET FLM 2.15K 1% 1/8W FACTORY SELECTED PART	
A14R39	0757-0442	R:FXD MET FLM 10.0K 1% 1/8W	
A14R40	0683-4315	R:FXD COMP 430 OHM 5% 1/4W	
A14R41	0698-0083	R:FXD MET FLM 1.96K OHM 1% 1/8W	
A14R42	0757-0442	R:FXD MET FLM 10.0K 1% 1/8W	
A14R43	0757-0428	R:FXD MET FLM 1.62K 1% 1/8W FACTORY SELECTED PART	
A14R44	0757-0442	R:FXD MET FLM 10.0K 1% 1/8W	
A14R45	0698-3150	R:FXD MET FLM 2.37K OHM 1% 1/8W	
A14R46	0698-3155	R:FXD MET FLM 4.64K 1% 1/8W	
A14R47	0683-0275	R:FXD COMP 2.7 OHM 5% 1/4W	
A14R48	0683-6235	R:FXD COMP 62K OHM 5% 1/4W	
A14R49	0698-3409	R:FXD MET FLM 2.37K OHM 1% 1/2W	
A14R50	2100-2632	R:VAR FLM 100 OHM 10% LIN 1/2W	
A14R51	0757-0421	R:FXD MET FLM 825 OHM 1% 1/8W	
A14R52	0683-6205	R:FXD COMP 62 OHM 5% 1/4W	
A14R53	0683-5115	R:FXD COMP 510 OHM 5% 1/4W	
A14S1	3101-1277	SWITCH:TOGGLE SPDT	
A14TP1	0360-1514	TERMINAL PIN:SQUARE	
A14TP2	0360-1514	TERMINAL PIN:SQUARE	
A14TP3	0360-1514	TERMINAL PIN:SQUARE	
A14TP4	0360-1514	TERMINAL PIN:SQUARE	
A15	08443-60014 08443-60114	BOARD ASSY:RECTIFIER EXCHANGE RECTIFIER ASSY	
A15C1	0160-3043	C:FXD CER 2 X 0.005 UF 20% 250VAC	
A15C2	0160-3043	C:FXD CER 2 X 0.005 UF 20% 250VAC	
A15C3	0180-2212	C:FXD ELECT 10 UF +50-10% 450VDCW	
A15C4	0170-0040	C:FXD MY 0.047 UF 10% 200VDCW	
A15C5	0170-0040	C:FXD MY 0.047 UF 10% 200VDCW	
A15C6	0150-0096	C:FXD CER 0.05 UF +80-20% 100VDCW	
A15C7	0150-0096	C:FXD CER 0.05 UF +80-20% 100VDCW	
A15C8	0150-0096	C:FXD CER 0.05 UF +80-20% 100VDCW	
A15C9	0150-0096	C:FXD CER 0.05 UF +80-20% 100VDCW	
A15C10	0160-0168	C:FXD MY 0.1 UF 10% 200VDCW	
A15CR1	1901-0159	DIODE:SILICON 0.75A 400PIV	
A15CR2	1901-0159	DIODE:SILICON 0.75A 400PIV	
A15CR3	1901-0159	DIODE:SILICON 0.75A 400PIV	
A15CR4	1901-0159	DIODE:SILICON 0.75A 400PIV	
A15CR5	1901-0200	DIODE:SILICON 100 PIV 3A	

See introduction to this section for ordering information

Table 6-3. Parts Indexed by Reference Designation (Cont.)

Reference Designation	Part No.	Description #	Note
A15CR6	1901-0200	DIODE:SILICON 100 PIV 3A	
A15CR7	1901-0200	DIODE:SILICON 100 PIV 3A	
A15CR8	1901-0200	DIODE:SILICON 100 PIV 3A	
A15CR9	1901-0159	DIODE:SILICON 0.75A 400PIV	
A15CR10	1901-0159	DIODE:SILICON 0.75A 400PIV	
A15CR11	1901-0025	DIODE:SILICON 100MA/1V	
A15CR12	1902-0041	DIODE:BREAKDOWN 5.11V 5%	
A15F1	2110-0004	FUSE:CARTRIDGE 1/4 AMP 250V	
A15F2	2110-0001	FUSE:CARTRIDGE 1A 250V FAST-BLOW	
A15F3	2110-0001	FUSE:CARTRIDGE 1A 250V FAST-BLOW	
A15F4	2110-0002	FUSE:CARTRIDGE 2 AMP 3 AG	
A15F5	2110-0001	FUSE:CARTRIDGE 1A 250V FAST-BLOW	
A15MP1	2110-0269	CLIP:FUSE 0.250" DIA	
A15MP2	2110-0269	CLIP:FUSE 0.250" DIA	
A15MP3	2110-0269	CLIP:FUSE 0.250" DIA	
A15MP4	2110-0269	CLIP:FUSE 0.250" DIA	
A15MP5	2110-0269	CLIP:FUSE 0.250" DIA	
A15MP6	2110-0269	CLIP:FUSE 0.250" DIA	
A15MP7	2110-0269	CLIP:FUSE 0.250" DIA	
A15MP8	2110-0269	CLIP:FUSE 0.250" DIA	
A15MP9	2110-0269	CLIP:FUSE 0.250" DIA	
A15MP10	2110-0269	CLIP:FUSE 0.250" DIA	
A15Q1	1854-0071	Q:SI NPN(SELECTED FROM 2N3704)	
A15Q2	1854-0232	Q:SI NPN(SELECTED FROM 2N3440)	
A15Q3	1854-0232	Q:SI NPN(SELECTED FROM 2N3440)	
A15R1	0812-0012	R:FXD WW 18 OHM 5% 3W	
A15R2	0757-0063	R:FXD MET FLM 196K OHM 1% 1/2W	
A15R3	0757-0063	R:FXD MET FLM 196K OHM 1% 1/2W	
A15R4	0757-0063	R:FXD MET FLM 196K OHM 1% 1/2W	
A15R5	0683-1025	R:FXD COMP 1000 OHM 5% 1/4W	
A15R6	0757-0442	R:FXD MET FLM 10.0K 1% 1/8W	
A15R7	0683-1025	R:FXD COMP 1000 OHM 5% 1/4W	
A15R8	0757-0855	R:FXD MET FLM 68.1K OHM 1% 1/2W	
A15R9	0683-1045	R:FXD COMP 100K OHMS 5% 1/4W	
A15R10	0757-0442	R:FXD MET FLM 10.0K 1% 1/8W	
A15R11	0757-0274	R:FXD MET FLM 1.21K OHM 1% 1/8W FACTORY SELECTED PART	
A15R12	0757-0442	R:FXD MET FLM 10.0K 1% 1/8W	
A15R13	0683-1855	R:FXD COMP 1.8 MEGOHM 5% 1/4W	
A16	08443-60038	BOARD ASSY:SWITCH	
A17	08443-60036	BOARD ASSY:8CD	
	08443-20036	BOARD:BLANK PC	
	3101-0070	SWITCH:SLIDE	
	1251-0087	CUNNECTOR:FEMALE 50-PIN MINAT	
A18	08443-60016	BOARD ASSY:MOTHER	

See introduction to this section for ordering information

Table 6-3. Parts Indexed by Reference Designation (Cont.)

Reference Designation	Part No.	Description #	Note
	08443-20016	BOARD:BLANK PC	
A18C1	0180-2181	C:FXD ELECT 1300 UF +75-10% 50VDCW	
A18C2	0180-2290	C:FXD ELECT 2700 UF +75-10% 25VDCW	
A18C3	0180-2181	C:FXD ELECT 1300 UF +75-10% 50VDCW	
A18C4	0150-0050	C:FXD CER DISC 1000 PF +80-20% 100VDCW	
A18Q1	1854-0063	Q:SI NPN	
A18Q2	1854-0063	Q:SI NPN	
A18Q3	1854-0063	Q:SI NPN	
A18Q4	1854-0063	Q:SI NPN	
A18Q5	1854-0324	Q:SI NPN JEDEC TYPE 2N3739	
A18R1	0683-2005	R:FXD COMP 20 OHM 5% 1/4W	
A18R2	0811-1666	R:FXD WW 1.0 OHM 5% 2W	
A18R3	0811-1666	R:FXD WW 1.0 OHM 5% 2W	
A18R4	0811-1661	R:FXD WW 0.39 OHM 5% 2W	
A18R5	0811-1666	R:FXD WW 1.0 OHM 5% 2W	
A18R6	0683-3615	R:FXD COMP 360 OHM 5% 1/4W	
A18R7	0683-2015	R:FXD COMP 200 OHM 5% 1/4W	
A18R8	2100-2886	R:VAR WW 5K OHM 5% LIN 2W	
A18R9	2100-2501	R:VAR WW 2K OHM 20% LIN 1.5W	
A18R10	2100-2729	R:VAR CERMET 2.5K OHM 20% LIN 2W	
A18R11	2100-2066	R:VAR COMP 2K OHM 20% LIN 1/2W	
A18R12	0757-0779	R:FXD MET FLM 3.16K OHM 1% 1/8W	
A18R13	2100-2898	R:VAR CERMET 5K/50K OHM 20% LIN	
A18XA1	1251-1887	CONNECTOR:PC 44 CONTACTS(2 X 22)	
A18XA2-		NOT ASSIGNED	
A18XA4			
A18XA5	1251-1626	CONNECTOR:PC (2 X 12) 24 CONTACT	
A18XA6	1251-1626	CONNECTOR:PC (2 X 12) 24 CONTACT	
A18XA7	1251-1626	CONNECTOR:PC (2 X 12) 24 CONTACT	
A18XA8	1251-0472	CONNECTOR:PC 12 CONTACTS	
A18XA9	1251-0472	CONNECTOR:PC 12 CONTACTS	
A18XA10	1251-0472	CONNECTOR:PC 12 CONTACTS	
A18XA11	1251-0472	CONNECTOR:PC 12 CONTACTS	
A18XA12	1251-0472	CONNECTOR:PC 12 CONTACTS	
A18XA13	1251-0472	CONNECTOR:PC 12 CONTACTS	
A18XA14	1251-1626	CONNECTOR:PC (2 X 12) 24 CONTACT	
A18XA15	1251-1626	CONNECTOR:PC (2 X 12) 24 CONTACT	
A18XA16	1251-2091	CONNECTOR:PC (1 X 15) 15 CONTACT	
A18XA17	1251-1887	CONNECTOR:PC 44 CONTACTS(2 X 22)	
	1251-2366	CONNECTOR:R AND P 8 POSITIONS	
CHASSIS PARTS			
OS1	2140-0253	LAMP:INCANDESCENT 28V 0.030A	
OS2	2140-0253	LAMP:INCANDESCENT 28V 0.030A	
FL1	9100-2878	FILTER-LINE 2A	
S1	3101-1234	SWITCH:SLIDE DPDT	

See introduction to this section for ordering information

Table 6-3. Parts Indexed by Reference Designation (Cont.)

Reference Designation	Part No.	Description #	Note	
T1	9100-2886	TRANSFORMER:POWER		
	08443-60049	CABLE ASSY:INTERCONNECTION		
	08443-60051	CABLE ASSY:TIME BASE INPUT		
	08443-60052	CABLE ASSY:BLANK CONTROL		
	08443-60053	CABLE ASSY:SCAN CONTROL		
	08443-60054	CABLE ASSY:SECOND LOCAL OSCILLATOR		
	08443-60055	CABLE ASSY:THIRD LOCAL OSCILLATOR		
	08443-60056	CABLE ASSY:TRIGGER GENERATOR COUNTER		
	08443-60057	CABLE ASSY:RF, VIOLET		
	08443-60058	CABLE ASSY:RF, GREEN		
	08443-60059	CABLE ASSY:1 MHZ INPUT		
	08443-60060	CABLE ASSY:1 MHZ OUTPUT		
	08443-60061	CABLE ASSY:EXT INPUT		
	08443-60062	CABLE ASSY:ATTENUATOR INPUT		
	08443-60063	CABLE ASSY:FIRST LOCAL OSCILLATOR		
	08443-60064	CABLE ASSY		
			MISCELLANEOUS	
	0370-0084		KNOB:ROUND BLK 5/8 DIA	
	1251-0198		CONNECTOR:P C 12 CONTACT	
	1251-2357		CONNECTOR:AC POWER 3 MALE CONTACTS	
	1251-2366		CONNECTOR:R AND P 8 POSITIONS	
	1251-2400		CONNECTOR:PC (2 X 15) 30 CONTACT	
	1400-0084		FUSEHOLDER:EXTRACTOR POST TYPE	
	1450-0153		LAMPHOLDER:FOR T-1 SERIES	
	1450-0157		LENS:LAMPHOLDER	
	1450-0493		LENS:PLASTIC	
	1490-0030		STAND:TILT	
	5040-0212		COUPLER:BAKELITE	
	5060-0216		BRACKET:JOINING KIT	
	08443-00024		DIAL KNOB ASSY:"TENS"	
	08443-00025		DIAL KNOB ASSY:"UNITS"	
	08443-00026		DIAL KNOB ASSY:"TENTHS"	
	08443-20004		SHAFT:ATTENUATOR KNOB	
	08443-40001		WINDOW:COUNTER	
	08443-00046		COVER, SERIES REGULATOR	
	08553-60063		CAPACITOR ASSY	
	08443-00043		COVER, POWER SUPPLY	

See introduction to this section for ordering information

Table 6-4. Parts Indexed by HP Part Number

Part No.	Description #	Mfr.	Mfr. Part No.	TQ
0121-0036	C:VAR CER 5.5-18 PF	28480	0121-0036	4
0121-0059	C:VAR CER 2-8 PF 300VDCW	28480	0121-0059	3
0121-0105	C:VAR CER 9-35 PF NPD	28480	0121-0105	1
0121-0446	C:VAR CER 4.5-20 PF 160VDCW N750	28480	0121-0446	1
0122-0049	DIGDE TUNING:90 PF 10%	28480	0122-0049	1
0122-0285	C:VOLTAGE VAR 6.8 PF 5%	04713	SMV 389-285	1
0150-0011	C:FXD TI 1.5 PF 20% 500VDCW	78488	TYPE GA	1
0150-0050	C:FXD CER DISC 1000 PF +80-20% 1000VDCW	56289	C0678102E102ZE19-CDH	30
0150-0096	C:FXD CER 0.05 UF +80-20% 100VDCW	91418	TA	8
0160-0145	C:FXD MICA 82PF 2% 100VDCW	04062	RDM15E820G6S	1
0160-0157	C:FXD MY 0.0047 UF 10% 200VDCW	56289	192P47292-PTS	1
0160-0163	C:FXD MY 0.033 UF 10% 200VDCW	56289	192P33392-PTS	1
0160-0168	C:FXD MY 0.1 UF 10% 200VDCW	28480	0160-0168	1
0160-0778	C:FXD CER 56 PF 10% 500VDCW	01121	F82B	1
0160-0949	C:FXD MICA 68 PF 5%	28480	0160-0949	1
0160-2013	C:FXD MICA 39 PF 5%	04062	RDM15E390J3S	2
0160-2016	C:FXD MICA 62 PF 5% 500VDCW	04062	RDM15E620J5S	2
0160-2055	C:FXD CER 0.01 UF +80-20% 100VDCW	91418	TA	16
0160-2139	C:FXD CER 220 PF +80-20% 1000VDCW	91418	TYPE B	10
0160-2140	C:FXD CER 470 PF +80-20% 1000VDCW	91418	TYPE B	9
0160-2142	C:FXD CER 1500 PF +100-0% 500VDCW	91418	TYPE SM	1
0160-2143	C:FXD CER 2000 PF +80-20% 1000VDCW	91418	TYPE B	3
0160-2145	C:FXD CER 5000 PF +80-20% 100VDCW	91418	TA	12
0160-2201	C:FXD MICA 51 PF 5%	72136	RDM15E510J1C	1
0160-2204	C:FXD MICA 100PF 5%	72136	RDM15F101J3C	4
0160-2208	C:FXD MICA 330 PF 5% 300VDCW	28480	0160-2208	1
0160-2218	C:FXD MICA 1000 PF 5%	28480	0160-2218	1
0160-2229	C:FXD MICA 3000 PF 5%	28480	0160-2229	1
0160-2247	C:FXD CER 3.9±0.25 PF 500VDCW	72982	301-NPO-3.9 PF	1
0160-2254	C:FXD CER 7.5±0.25 PF 500VDCW	72982	301-000-COHQ-759C	3
0160-2257	C:FXD CER 10 PF 5% 500VDCW	72982	301-000-COHQ-100J	1
0160-2258	C:FXD CER 11 PF 5% 500VDCW	72982	301-000-COGQ-110J	4
0160-2260	C:FXD CER 13 PF 5% 500VDCW	72982	301-000-COGQ 130J	1
0160-2307	C:FXD MICA 47 PF 5%	28480	0160-2307	1
0160-2327	C:FXD CER 1000 PF 20% 100VDCW	96733	B1048X102M	10
0160-2362	C:FXD MICA 140 PF 2% 300VDCW	04062	RDM15F141G3S	1
0160-2930	C:FXD CER 0.01 UF +80-20% 100VDCW	91418	TA	6
0160-3036	C:FXD CER 5000 PF +80-20% 200VDCW	28480	0160-3036	2
0160-3043	C:FXD CER 2 X 0.005 UF 20% 250VAC	56289	29C147A-CDH	2
0160-3060	C:FXD CER 0.1 UF 20% 25VDCW	56289	3C42A-CML	3
0160-3425	C:FXD CER 33 PF 5% 500VDCW	72982	301-000-R2G-330J	1
0160-3453	C:FXD CER 0.05 UF +80-20% 100VDCW	56289	C023A101L503ZE15-CDH	1
0170-0040	C:FXD MY 0.047 UF 10% 200VDCW	56289	192P47392-PTS	2
0180-0098	C:FXD ELECT 100 UF 20% 20VDCW	56289	150D107X0020S2-DYS	1
0180-0116	C:FXD ELECT 0.8 UF 10% 35VDCW	28480	0180-C116	5
0180-0137	C:FXD ELECT 100 UF 20% 10VDCW	56289	150D107X0010R2-DYS	1
0180-0160	C:FXD ELECT 22 UF 20% 35VDCW	28480	0180-0160	1
0180-0197	C:FXD ELECT 2.2 UF 10% 20VDCW	56289	150D225X9020A2-DYS	12
0180-0229	C:FXD ELECT 33 UF 10% 10VDCW	28480	0180-0229	1
0180-0291	C:FXD ELECT 1.0 UF 10% 35VDCW	56289	150D105X9035A2-DYS	3
0180-0376	C:FXD ELECT 0.47 UF 10% 35VDCW	28480	0180-0376	6
0180-1735	C:FXD ELECT 0.22 UF 10% 35VDCW	28480	0180-1735	2
0180-1743	C:FXD ELECT 0.1 UF 10% 35VDCW	56289	150D104X9035A2-DYS	4
0180-1747	C:FXD ELECT 150 UF 20% 15VDCW	28480	0180-1747	1
0180-2181	C:FXD ELECT 1300 UF +75-10% 50VDCW	56289	36D132G050AA2A-DQB	2

See introduction to this section for ordering information

Table 6-4. Parts Indexed by HP Part Number (Cont.)

Part No.	Description #	Mfr.	Mfr. Part No.	TQ
0180-2212	C:FXD ELECT 10 UF +50-10% 450VDCW	56289	39D106F450FL4-DSB	1
0180-2290	C:FXD ELECT 2700 UF +75-10% 25VDCW	56289	36D272G025AA2A-DQB	1
0360-1514	TERMINAL PIN:SQUARE	28480	0360-1514	4
0370-0084	KNOB:ROUND BLK 5/8" DIA	28480	0370-0084	2
0400-0009	GRUMMET:VINYL FITS 1/4" DIA HDLE	01538	G250	8
0410-0196	CRYSTAL:QUARTZ	28480	0410-0196	1
0683-0275	R:FXD COMP 2.7 OHM 5% 1/4W	01121	CB 2765	4
0683-1005	R:FXD COMP 10 OHM 5% 1/4W	01121	CB 1005	3
0683-1015	R:FXD COMP 100 OHM 5% 1/4W	01121	CB 1015	4
0683-1025	R:FXD COMP 1000 OHM 5% 1/4W	01121	CB 1025	13
0683-1045	R:FXD COMP 100K OHMS 5% 1/4W	01121	CB 1045	3
0683-1125	R:FXD COMP 1100 OHM 5% 1/4W	01121	CB 1125	1
0683-1135	R:FXD COMP 11K OHM 5% 1/4W	01121	CB 1135	5
0683-1315	R:FXD COMP 130 OHM 5% 1/4W	01121	CB 1315	3
0683-1565	R:FXD COMP 15 MEGOHM 5% 1/4W	01121	CB 1565	1
0683-1635	R:FXD COMP 16K OHM 5% 1/4W	01121	CB 1635	2
0683-1855	R:FXD COMP 1.8 MEGOHM 5% 1/4W	01121	CB 1855	1
0683-2005	R:FXD COMP 20 OHM 5% 1/4W	01121	CB 2005	1
0683-2015	R:FXD COMP 200 OHM 5% 1/4W	01121	CB 2015	1
0683-3025	R:FXD COMP 3000 OHM 5% 1/4W	01121	CB 3025	7
0683-3035	R:FXD COMP 30K OHM 5% 1/4W	01121	CB 3035	1
0683-3615	R:FXD COMP 360 OHM 5% 1/4W	01121	CB 3615	1
0683-4315	R:FXD COMP 430 OHM 5% 1/4W	01121	CB 4315	1
0683-5115	R:FXD COMP 510 OHM 5% 1/4W	01121	CB 5115	5
0683-5125	R:FXD COMP 5100 OHM 5% 1/4W	01121	CB 5125	3
0683-5135	R:FXD COMP 51K OHM 5% 1/4W	01121	CB 5135	1
0683-6205	R:FXD COMP 62 OHM 5% 1/4W	01121	CB 6205	2
0683-6225	R:FXD COMP 6200 OHM 5% 1/4W	01121	CB 6225	1
0683-6235	R:FXD COMP 62K OHM 5% 1/4W	01121	CB 6235	2
0683-6825	R:FXD COMP 6800 OHM 5% 1/4W	01121	CB 6825	8
0698-7525	R:FXD COMP 7500 OHM 5% 1/4W	01121	CB 7525	1
0698-0082	R:FXD MET FLM 464 OHM 1% 1/8W	14674	C4	1
0698-0083	R:FXD MET FLM 1.96K OHM 1% 1/8W	14674	C4	5
0698-0084	R:FXD MET FLM 2.15K 1% 1/8W	14674	C4	8
0698-0085	R:FXD MET FLM 2.61K OHM 1% 1/8W	14674	C4	3
0698-3150	R:FXD MET FLM 2.37K OHM 1% 1/8W	28480	0698-3150	2
0698-3151	R:FXD MET FLM 2.87K OHM 1% 1/8W	28480	0698-3151	3
0698-3153	R:FXD MET FLM 3.83K 1% 1/8W	91637	MFF-1/10-32	4
0698-3155	R:FXD MET FLM 4.64K 1% 1/8W	91637	MFF-1/10-32	5
0698-3159	R:FXD MET FLM 26.1K OHM 1% 1/8W	75042	CEA	1
0698-3260	R:FXD MET FLM 464K OHM 1% 1/8W	91637	CMF-1/10-32	1
0698-3334	R:FXD MET FLM 178 OHM 1% 1/2W	28480	0698-3334	1
0698-3401	R:FXD MET FLM 215 OHM 1% 1/2W	28480	0698-3401	1
0698-3409	R:FXD MET FLM 2.37K OHM 1% 1/2W	28480	0698-3409	2
0698-3428	R:FXD MET FLM 14.7 OHM 1% 1/8W	28480	0698-3428	2
0698-3429	R:FXD MET FLM 19.6 OHM 1% 1/8W	28480	0698-3429	4
0698-3431	R:FXD MET FLM 23.7 OHM 1% 1/8W	28480	0698-3431	2
0698-3433	R:FXD MET FLM 28.7 OHM 1% 1/8W	28480	0698-3433	1
0698-3434	R:FXD MET FLM 34.8 OHM 1% 1/8W	28480	0698-3434	2
0698-3435	R:FXD MET FLM 38.3 OHM 1% 1/8W	91637	MFF-1/2-10	3
0698-3437	R:FXD MET FLM 133 OHM 1% 1/8W	91637	MF-1/2-32	1
0698-3438	R:FXD MET FLM 147 OHM 1% 1/8W	28480	0698-3438	2
0698-3441	R:FXD MET FLM 215 OHM 1% 1/8W	91637	MF-1/10-32	7
0698-3443	R:FXD MET FLM 287 OHM 1% 1/8W	91637	MF-1/10-32	2

See introduction to this section for ordering information

Table 6-4. Parts Indexed by HP Part Number (Cont.)

Part No.	Description #	Mfr.	Mfr. Part No.	TQ
0698-3444	R:FXD MET FLM 316 OHM 1% 1/8W	28480	0698-3444	3
0698-3452	R:FXD MET FLM 147K OHM 1% 1/8W	28480	0698-3452	1
0698-7222	R:FXD FLM 261 OHM 2% 1/8W	28480	0698-7222	1
0698-7229	R:FXD FLM 511 OHM 2% 1/8W	28480	0698-7229	2
0698-7236	R:FXD FLM 1K OHM 2% 1/8W	28480	0698-7236	3
0699-0001	R:FXD COMP 2.7 OHM 10% 1/2W	01121	EB 27G1	1
0727-0005	R:FXD DEPC 5.77 OHM 1/2% 1/2W	28480	0727-0005	1
0727-0008	R:FXD DEPC 11.61 OHM 1/2% 1/2W	28480	0727-0008	1
0727-0010	R:FXD DEPC 17.61 OHM 1/2% 1/2W	28480	0727-0010	3
0727-0028	R:FXD DEPC 53.3 OHM 1/2% 1/2W	28480	0727-0028	6
0727-0034	R:FXD DEPC 61.11 OHM 1/2% 1/2W	28480	0727-0034	2
0727-0037	R:FXD DEPC 71.16 OHM 1/2% 1/2W	28480	0727-0037	1
0727-0042	R:FXD DEPC 96.25 OHM 1/2% 1/2W	28480	0727-0042	2
0727-0062	R:FXD DEPC 247.5 OHM 1/2% 1/2W	28480	0727-0062	1
0727-0064	R:FXD DEPC 292.4 OHM 1/2% 1/2W	28480	0727-0064	4
0727-0074	R:FXD DEPC 436 OHM 1/2% 1/2W	28480	0727-0074	2
0727-0091	R:FXD DEPC 790 OHM 1/2% 1/2W	28480	0727-0091	3
0727-0094	R:FXD DEPC 870 OHM 1/2% 1/2W	28480	0727-0094	2
0727-0379	R:FXD DEPC 146.2 OHM 1/2% 1/2W	28480	0727-0379	1
0757-0063	R:FXD MET FLM 196K OHM 1% 1/2W	28480	0757-0063	3
0757-0159	R:FXD MET FLM 1000 OHM 1% 1/2W	28480	0757-0159	2
0757-0180	R:FXD MET FLM 31.6 OHM 1% 1/8W	28480	0757-0180	1
0757-0199	R:FXD MET FLM 21.5K OHM 1% 1/8W	14674	C4	6
0757-0274	R:FXD MET FLM 1.21K OHM 1% 1/8W	28480	0757-0274	2
0757-0276	R:FXD MET FLM 61.9 OHM 1% 1/8W	28480	0757-0276	3
0757-0279	R:FXD MET FLM 3.16K OHM 1% 1/8W	14674	C4	7
0757-0280	R:FXD MET FLM 1K OHM 1% 1/8W	14674	C4	5
0757-0288	R:FXD MET FLM 9.09K OHM 1% 1/8W	14674	C4	2
0757-0289	R:FXD MET FLM 13.3K OHM 1% 1/8W	28480	0757-0289	1
0757-0346	R:FXD MET FLM 10 OHM 1% 1/8W	28480	0757-0346	3
0757-0394	R:FXD MET FLM 51.1 OHM 1% 1/8W	14674	C4	6
0757-0395	R:FXD MET FLM 56.2 OHM 1% 1/8W	01295	MC550	2
0757-0397	R:FXD MET FLM 68.1 OHM 1% 1/8W	28480	0757-0397	2
0757-0398	R:FXD MET FLM 75 OHM 1% 1/8W	28480	0757-0398	3
0757-0401	R:FXD MET FLM 100 OHM 1% 1/8W	14674	C4	6
0757-0403	R:FXD MET FLM 121 OHM 1% 1/8W	14674	C4	1
0757-0405	R:FXD MET FLM 162 OHM 1% 1/8W	28480	0757-0405	2
0757-0416	R:FXD MET FLM 511 OHM 1% 1/8W	14674	C4	10
0757-0417	R:FXD MET FLM 562 OHM 1% 1/8W	14674	C4	4
0757-0418	R:FXD MET FLM 619 OHM 1% 1/8W	14674	C4	1
0757-0419	R:FXD MET FLM 681 OHM 1% 1/8W	14674	C4	1
0757-0420	R:FXD MET FLM 750 OHM 1% 1/8W	14674	C4	5
0757-0421	R:FXD MET FLM 825 OHM 1% 1/8W	28480	0757-0421	2
0757-0422	R:FXD MET FLM 909 OHM 1% 1/8W	28480	0757-0422	1
0757-0428	R:FXD MET FLM 1.62K 1% 1/8W	14674	C4	3
0757-0438	R:FXD MET FLM 5.11K 1% 1/8W	14674	C4	16
0757-0440	R:FXD MET FLM 7.50K 1% 1/8W	14674	C4	2
0757-0442	R:FXD MET FLM 10.0K 1% 1/8W	14674	C4	21
0757-0458	R:FXD MET FLM 51.1K OHM 1% 1/8W	91637	MF-1/10-32	3
0757-0459	R:FXD MET FLM 56.2K OHM 1% 1/8W	91637	MF-1/10-32	1
0757-0815	R:FXD MET FLM 562 OHM 1% 1/2W	28480	0757-0815	2
0757-0821	R:FXD MET FLM 1.21K OHM 1% 1/2W	28480	0757-0821	1
0757-0855	R:FXD MET FLM 68.1K OHM 1% 1/2W	28480	0757-0855	1
0757-1001	R:FXD MET FLM 56.2 OHM 1% 1/2W	28480	0757-1001	1

See introduction to this section for ordering information

Table 6-4. Parts Indexed by HP Part Number (Cont.)

Part No.	Description #	Mfr.	Mfr. Part No.	TQ
0757-1060	R:FXD MET FLM 196 OHM 1% 1/2W	28480	0757-1060	1
0757-1092	R:FXD MET FLM 287 OHM 1% 1/2W	28480	0757-1092	1
0757-1094	R:FXD MET FLM 1.47K OHM 1% 1/8W	28480	0757-1094	1
0811-1661	R:FXD WW 0.39 OHM 5% 2W	28480	0811-1661	1
0811-1666	R:FXD WW 1.0 OHM 5% 2W	28480	0811-1666	3
0812-0012	R:FXD WW 18 OHM 5% 3W	28480	0812-0012	1
0960-0079	OSCILLATOR-CRYSTAL ASSY: 1.0 MHZ	28480	0960-0079	1
1200-0465	SOCKET:TUBE FOR 5700 SERIES	83594	SK 207	8
1200-0770	SOCKET:CRYSTAL	91506	8000-AG-26	1
1250-0835	CONNECTOR:RF PC MOUNT	98291	50-051-0000	1
1250-1195	CONNECTOR:RF SUB-MINIATURE SERIES	98291	52-053-0000	11
1251-0087	CONNECTOR:FEMALE 50-PIN MINAT	28480	1251-0087	1
1251-0198	CONNECTOR:PC 12 CONTACT	28480	1251-0198	1
1251-0472	CONNECTOR:PC 12 CONTACTS	71785	252-06-30-300	6
1251-1556	CONNECTOR:SINGLE CONTACT	00779	2-330808-8	1
1251-1626	CONNECTOR:PC (2 X 12) 24 CONTACT	71785	252-12-30-300	5
1251-1887	CONNECTOR:PC 44 CONTACTS(2 X 22)	71785	252-22-30-340	2
1251-2091	CONNECTOR:PC (1 X 15) 15 CONTACT	95354	178-111-05	1
1251-2357	CONNECTOR:AC POWER 3 MALE CONTACTS	82389	EAC-301	1
1251-2366	CONNECTOR:R AND P 8 POSITIONS	71468	UCM 8W8S	2
1251-2400	CONNECTOR:PC (2 X 15) 30 CONTACT	11453	610-093-15	1
1400-0084	FUSEHOLDER:EXTRACTOR POST TYPE	79515	342014	1
1450-0153	LAMPHOLDER:FOR T-1 SERIES	08717	102SR	2
1450-0157	LENS:LAMPHOLDER	08717	102XX-W	1
1450-0493	LENS:PLASTIC	28480	1450-0493	1
1490-0030	STAND:TILT	28480	1490-0030	1
1820-0054	IC:TTL QUAD 2-INPUT NAND GATE	01295	SN4342	2
1820-0077	IC:TTL DUAL D FF (LATCH)	01295	SN4354	1
1820-0092	INTEGRATED CIRCUIT:DECODER-DIVIDER	28480	1820-0092	7
1820-0101	INTEGRATED CIRCUIT:DIFFERENTIAL AMPL	04713	MC1034P	1
1820-0102	INTEGRATED CIRCUIT:J-K FLIP FLOP	04713	MC1013P	4
1820-0116	IC:4-BIT BUFF STORE GATED OUTS	28480	1820-0116	7
1820-0117	INTEGRATED CIRCUIT	28480	1820-0117	1
1820-0119	INTEGRATED CIRCUIT	28480	1820-0119	5
1820-0174	INTEGRATED CIRCUIT:TTL HEX INVERTER	01295	SN8199	1
1820-0267	INTEGRATED CIRCUIT:POWER AMPL.	28480	1820-0267	1
1820-0275	INTEGRATED CIRCUIT:DIGITAL	04713	SC 7023PK	1
1820-0304	IC:TTL J-K MASTER-SLAVE	01295	SN4464	2
1820-0403	INTEGRATED CIRCUIT:PRE-AMP	28480	1820-0403	1
1820-0412	INTEGRATED CIRCUIT:DECADE DIVIDER	28480	1820-0412	5
1853-0018	Q:SI PNP(SELECTED FROM 2N4260)	28480	1853-0018	1
1853-0020	Q:SI PNP(SELECTED FROM 2N3702)	28480	1853-0020	9
1853-0034	Q:SI PNP(SELECTED FROM 2N3251)	28480	1853-0034	1
1853-0089	Q:SI PNP	07263	2N4917	1
1854-0019	Q:SI NPN(SELECTED FROM 2N2369)	28480	1854-0019	4
1854-0022	Q:SI NPN	07263	S17843	4
1854-0023	Q:SI NPN(SELECTED FROM 2N2484)	28480	1854-0023	1
1854-0039	Q:SI NPN	04713	2N3053	4
1854-0063	Q:SI NPN	04713	2N3055	4
1854-0071	Q:SI NPN(SELECTED FROM 2N3704)	28480	1854-0071	38
1854-0221	Q:SI NPN(REPLACEABLE BY 2N4044)	28480	1854-0221	4
1854-0232	Q:SI NPN(SELECTED FROM 2N3440)	28480	1854-0232	2
1854-0247	Q:SI NPN	28480	1854-0247	3
1854-0324	Q:SI NPN JEDEC TYPE 2N3739	04713	2N3739	1

See introduction to this section for ordering information

Table 6-4. Parts Indexed by HP Part Number (Cont.)

Part No.	Description #	Mfr.	Mfr. Part No.	TQ
1854-0345	Q:SI NPN	02735	2N5179	7
1884-0012	RECTIFIER:SILICON CONTROLLED 2N3528	02735	2N3528	2
1901-0025	DIODE:SILICON 100MA/1V	07263	FD 2387	30
1901-0039	DIODE:SILICON 200MA 50WV	28480	1901-0039	2
1901-0047	DIODE JUNCTION:SILICON 20PIV	28480	1901-0047	6
1901-0050	DIODE:SILICON 75V	14433	S270	4
1901-0159	DIODE:SILICON 0.75A 400PIV	04713	SR1358-4	7
1901-0179	DIODE:SILICON 15WV	28480	1901-0179	2
1901-0200	DIODE:SILICON 100 PIV 3A	02735	1N4998	11
1901-0518	DIODE:HOT CARRIER	28480	1901-0518	3
1902-0033	DIODE:BREAKDOWN 6.2V	04713	1N823	1
1902-0041	DIODE:BREAKDOWN 5.11V 5%	04713	SZ10939-9B	1
1902-0048	DIODE:BREAKDOWN 6.81V 5%	04713	SZ10939-134	3
1902-0049	DIODE:BREAKDOWN 6.19V 5%	04713	SZ10939-122	1
1902-0518	DIODE BREAKDOWN:5.11V	28480	1902-0518	1
1902-3024	DIODE BREAKDOWN:2.87V 5%	28480	1902-3024	1
1902-3104	DIODE BREAKDOWN:5.62V 5%	28480	1902-3104	2
1902-3139	DIODE:BREAKDOWN 8.25V 5%	04713	SZ10939-158	2
1902-3193	DIODE BREAKDOWN:13.3V 5%	28480	1902-3193	1
1902-3256	DIODE:BREAKDOWN SILICON 23.7V 5%	28480	1902-3256	1
1902-3268	DIODE BREAKDOWN:26.1V 5%	28480	1902-3268	2
1910-0016	DIODE:GERMANIUM 100MA/0.85V 60PIV	93332	D2361	5
1970-0042	TUBE:NUMERICAL INDICATOR	83594	H-5750-S	16
2100-1758	R:VAR WW 1K OHM 5% TYPE V 1W	28480	2100-1758	1
2100-2066	R:VAR COMP 2K OHM 20% LIN 1/2W	28480	2100-2066	1
2100-2489	R:VAR FLM 5K OHM 10% LIN 1/2W	28480	2100-2489	1
2100-2501	R:VAR WW 2K OHM 20% LIN 1.5W	28480	2100-2501	1
2100-2517	R:VAR FLM 50K OHM 10% LIN 1/2W	28480	2100-2517	1
2100-2632	R:VAR FLM 100 OHM 10% LIN 1/2W	28480	2100-2632	1
2100-2729	R:VAR CERMET 2.5K OHM 20% LIN 2W	28480	2100-2729	1
2100-2886	R:VAR WW 5K OHM 5% LIN 2W	28480	2100-2886	1
2100-2898	R:VAR CERMET 5K/50K OHM 20% LIN	28480	2100-2898	1
2110-0001	FUSE:CARTRIDGE 1A 250V FAST-BLOW	71400	AGC-1	3
2110-0002	FUSE:CARTRIDGE 2 AMP 3 AG	75915	312.002	1
2110-0004	FUSE:CARTRIDGE 1/4 AMP 250V	75915	3AG/CAT. 312.250	1
2110-0269	CLIP:FUSE 0.250" DIA	91506	6008-32CN	10
2140-0253	LAMP:INCANDESCENT 28V 0.030A	08717	FB38	2
3101-0070	SWITCH:SLIDE	75727	G-126	1
3101-1213	SWITCH:TOGGLE SUB-MINIATURE	95707	T-8001	1
3101-1244	SWITCH:SLIDE DPDT	82389	11A-1242	1
3101-1277	SWITCH:TOGGLE SPDT	95707	T-8003	1
5040-0212	COUPLER:BAKELITE	28480	5040-0212	2
5060-0216	BRACKET:JOINING KIT	28480	5060-0216	1
9100-0346	COIL:FXD 0.05 UH 20%	36196	H-10886	1
9100-1610	COIL:MOLDED CHOKE 0.15 UH 20%	28480	9100-1610	2
9100-1611	COIL:FXD 0.22 UH 20%	28480	9100-1611	4
9100-1612	COIL:FXD RF 0.33 UH 20%	28480	9100-1612	3
9100-1616	COIL/CHOKE 1.50 UH 10%	99800	1537-16	6
9100-1618	COIL:MOLDED CHOKE 5.60 UH	28480	9100-1618	1
9100-1622	COIL/CHOKE 24.0 UH 5%	28480	9100-1622	1
9100-1623	COIL/CHOKE 27 UH 5%	28480	9100-1623	1
9100-1629	COIL/CHOKE 47.0 UH 5%	28480	9100-1629	6
9100-1630	COIL/CHOKE 51.0 UH 5%	28480	9100-1630	1
9100-1643	COIL/CHOKE 300 UH 5%	28480	9100-1643	2

See introduction to this section for ordering information

Table 6-4. Parts Indexed by HP Part Number (Cont.)

Part No.	Description #	Mfr.	Mfr. Part No.	TQ
9100-2247	COIL:FXD RF 0.10 UH 10%	28480	9100-2247	5
9100-2248	COIL/CHOKE 0.12 UH 10%	82142	09-4416-2K	1
9100-2878	FILTER-LINE 2A	05245	F-1262B	1
9100-2886	TRANSFORMER:POWER	28480	9100-2886	1
9100-3101	COIL:VAR 0.142 TO 0.158 UH	71279	CDD4C03-2	1
9100-3102	COIL:VAR 1.42 TO 1.58 UH	71279	CDD4C03-8	1
9100-3103	COIL:VAR 42.0 TO 51.5 UH	71279	CDD4C03-18	1
9140-0051	COIL:FXD 400 UH	28480	9140-0051	1
9140-0096	COIL:FXD RF 1 UH	28480	9140-0096	4
9140-0114	COIL:FXD RF 10 UH	28480	9140-0114	1
9140-0129	COIL:FXD RF 220 UH	28480	9140-0129	4
9140-0141	COIL:FXD RF 0.68 UH	28480	9140-0141	2
9140-0144	COIL:FXD RF 4.7 UH	28480	9140-0144	3
9140-0158	COIL:FXD RF 1 UH 10%	55600	1D25-20	7
08443-00009	COVER:TOP COUNTER BOX	28480	08443-00009	1
08443-00016	BRACKET:RETAINING	28480	08443-00016	1
08443-00024	DIAL KNOB ASSY:"TENS"	28480	08443-00024	1
08443-00025	DIAL KNOB ASSY:"UNITS"	28480	08443-00025	1
08443-00026	DIAL KNOB ASSY:"TENTHS"	28480	08443-00026	1
08443-00041	TEST POINT	28480	08443-00041	19
08443-00042	COUNTER BOX	28480	08443-00042	1
08443-00043	COVER, POWER SUPPLY	28480	08443-00043	1
08443-00044	GUIDE:CONNECTOR BOARD	28480	08443-00044	1
08443-00046	COVER, SERIES REGULATOR	28480	08443-00046	1
08443-20004	SHAFT:ATTENUATOR KNOB	28480	08443-20004	2
08443-20016	BOARD:BLANK PC	28480	08443-20016	1
08443-20017	BOARD:BLANK PC	28480	08443-20017	1
08443-20018	BOARD:BLANK PC	28480	08443-20018	1
08443-20019	BOARD:BLANK PC	28480	08443-20019	1
08443-20020	BOARD:BLANK PC	28480	08443-20020	1
08443-20021	BOARD:BLANK PC	28480	08443-20021	1
08443-20022	BOARD:BLANK PC	28480	08443-20022	1
08443-20023	BOARD:BLANK PC	28480	08443-20023	1
08443-20024	BOARD:BLANK PC	28480	08443-20024	1
08443-20025	BOARD:BLANK PC	28480	08443-20025	1
08443-20026	BOARD:BLANK PC	28480	08443-20026	1
08443-20033	BOARD:BLANK PC	28480	08443-20033	1
08443-20034	BOARD:BLANK PC	28480	08443-20034	1
08443-20035	BOARD:BLANK PC	28480	08443-20035	1
08443-20036	BOARD:BLANK PC	28480	08443-20036	1
08443-20037	BOARD:BLANK PC	28480	08443-20037	1
08443-60001	WINDOW:COUNTER	28480	08443-60001	1
08443-60001	ATTENUATOR ASSY:10 DB	28480	08443-60001	1
08443-60002	ATTENUATOR ASSY:1 DB	28480	08443-60002	1
08443-60004	FILTER ASSY:50 MHZ	28480	08443-60004	1
08443-60005	MIXER ASSY:THIRD	28480	08443-60005	1
08443-60006	FILTER ASSY:120 MHZ	28480	08443-60006	1
08443-60007	FILTER ASSY:200 MHZ	28480	08443-60007	1
08443-60014	BOARD ASSY:RECTIFIER	28480	08443-60014	1
08443-60015	BOARD ASSY:SENSE AMPLIFIER	28480	08443-60015	1
08443-60016	BOARD ASSY:MOTHER	28480	08443-60016	1
08443-60019	BOARD ASSY:50 MHZ FILTER	28480	08443-60019	1
08443-60022	BOARD ASSY:VIDEO AMPLIFIER	28480	08443-60022	1
08443-60036	BOARD ASSY:BCD	28480	08443-60036	1
08443-60037	BOARD ASSY:LOW FREQ COUNTER	28480	08443-60037	1

See introduction to this section for ordering information

Table 6-4. Parts Indexed by HP Part Number (Cont.)

Part No.	Description #	Mfr.	Mfr. Part No.	TQ
08443-60038	BOARD ASSY:SWITCH	28480	08443-60038	1
08443-60039	BOARD ASSY:CONNECTOR	28480	08443-60039	1
08443-60040	CONVERTER ASSY:FIRST	28480	08443-60040	1
08443-60041	IF ASSY:50 MHZ	28480	08443-60041	1
08443-60042	CONVERTER ASSY:SECOND	28480	08443-60042	1
08443-60043	IF ASSY:200 MHZ	28480	08443-60043	1
08443-60044	CONVERTER ASSY:THIRD	28480	08443-60044	1
08443-60045	VIDEO ASSY:AMPLIFIER ALC	28480	08443-60045	1
08443-60046	MARKER CONTROL ASSY	28480	08443-60046	1
08443-60047	BOARD ASSY:RF DECADE	28480	08443-60047	1
08443-60048	BOARD ASSY:TIME BASE	28480	08443-60048	1
08443-60049	CABLE ASSY:INTERCONNECTION	28480	08443-60049	1
08443-60051	CABLE ASSY:TIME BASE INPUT	28480	08443-60051	1
08443-60052	CABLE ASSY:BLANK CONTROL	28480	08443-60052	1
08443-60053	CABLE ASSY:SCAN CONTROL	28480	08443-60053	1
08443-60054	CABLE ASSY:SECOND LOCAL OSCILLATOR	28480	08443-60054	1
08443-60055	CABLE ASSY:THIRD LOCAL OSCILLATOR	28480	08443-60055	1
08443-60056	CABLE ASSY:TRIGGER GENERATOR COUNTER	28480	08443-60056	1
08443-60057	CABLE ASSY:RF, VIOLET	28480	08443-60057	1
08443-60058	CABLE ASSY:RF, GREEN	28480	08443-60058	1
08443-60059	CABLE ASSY:1 MHZ INPUT	28480	08443-60059	1
08443-60060	CABLE ASSY:1 MHZ OUTPUT	28480	08443-60060	1
08443-60061	CABLE ASSY:EXT INPUT	28480	08443-60061	1
08443-60062	CABLE ASSY:ATTENUATOR INPUT	28480	08443-60062	1
08443-60063	CABLE ASSY:FIRST LOCAL OSCILLATOR	28480	08443-60063	1
08443-60064	CABLE ASSY	28480	08443-60064	2
08443-60066	LOW FREQUENCY COUNTER ASSY	28480	08443-60066	1
08443-80001	TRANSFORMER:RF	28480	08443-80001	2
08552-6017	INDUCTOR ASSY:50 MHZ	28480	08552-6017	1
08552-6018	TRANSFORMER:RF(CODE=RED)	28480	08552-6018	4
08552-6023	INDUCTOR ASSY:AIR CORE	28480	08552-6023	1
08552-6024	TRANSFORMER:RF(CODE=YELLOW)	28480	08552-6024	4
08553-6012	TRANSFORMER:RF(CODE=BLUE)	28480	08553-6012	4
08553-6018	INDUCTOR ASSY:AIR CORE	28480	08553-6018	2
08553-6036	CAPACITOR ASSY	28480	08553-6036	1
10514-8454	DIODE:SILICON MATCHED QUAD	28480	10514-8454	2

See introduction to this section for ordering information

Table 6-5. Code List of Manufacturers

The following code numbers are from the Federal Supply Code for Manufacturers Cataloging Handbooks H4-1 (Name to Code) and H4-2 (Code to Name) and their latest supplements. The date of revision and the date of the supplements used appear at the bottom of each page. Alphabetical codes have been arbitrarily assigned to suppliers not appearing in the H4 Handbooks.

Code No.	Manufacturer	Address	Code No.	Manufacturer	Address
00000	U.S.A Common	Any supplier of U.S.	05347	Ultronix, Inc.	San Mateo, Cal.
00136	McCoy Electronics	Mount Holly Springs, Pa.	05397	Union Carbine Corp., Elect. Div.	New York, N.Y.
00213	Sage Electronics Corp.	Rochester, N.Y.	05574	Viking Ind. Inc.	Canoga Park, Cal.
00287	Cemco, Inc.	Danielson, Conn	05593	Icore Electro-Plastics Inc.	Sunnyvale, Cal.
00334	Humidial	Colton, Calif.	05616	Cosmo Plastic (c/o Electrical Spec. Co.)	Cleveland, Ohio
00348	Mictron, Co., Inc.	Valley Stream, N.Y.	05624	Barber Colman Co.	Rockford, Ill.
00373	Garlock Inc.	Cherry Hill, N.J.	05728	Tiffen Optical Co.	Roslyn Heights, Long Island, N.Y.
00656	Aerovox Corp.	New Bedford, Mass.	05729	Metro-Tel Corp.	Westbury, N.Y.
00779	Amp. Inc.	Harrisburg, Pa.	05783	Stewart Engineering Co.	Santa Cruz, Cal.
00781	Aircraft Radio Corp.	Boonton, N.J.	05820	Wakefield Engineering Inc.	Wakefield, Mass.
00809	Croven, Ltd.	Whitby, Ontario, Canada	06004	Bassick Co., Div. of Stewart Warner Corp.	Bridgeport, Conn.
00815	Northern Engineering Laboratories, Inc.	Burlington, Wis.	06090	Raychem Corp.	Redwood City, Cal.
00853	Sangamo Electric Co., Pickens Div.	Pickens, S.C.	06175	Bausch and Lomb Optical Co.	Rochester, N.Y.
00866	Goe Engineering Co.	City of Industry, Cal.	06402	E.T.A. Products Co. of America	Chicago, Ill.
00891	Carl E. Holmes Corp.	Los Angeles, Cal.	06540	Amatom Electronic Hardware Co., Inc.	New Rochelle, N.Y.
00929	Microlab Inc.	Livingston, N.J.	06555	Beede Electrical Instrument Co., Inc.	Penacook, N.H.
01002	General Electric Co., Capacitor Dept.	Hudson Falls, N.Y.	06666	General Devices Co., Inc.	Indianapolis, Ind.
01009	Alden Products Co.	Brockton, Mass.	06751	Components Inc., Ariz. Div.	Phoenix, Arizona
01121	Allen Bradley Co.	Milwaukee, Wis.	06812	Torrington Mfg. Co., West Div.	Van Nuys, Cal.
01255	Litton Industries, Inc.	Beverly Hills, Cal.	06980	Varian Assoc. Etmac Div.	San Carlos, Cal.
01281	TRW Semiconductors, Inc.	Lawndale, Cal.	07088	Kelvin Electric Co.	Van Nuys, Cal.
01295	Texas Instruments, Inc., Transistor Products Div.	Dallas, Texas	07126	Digitran Co.	Pasadena, Cal.
01349	The Alliance Mfg. Co.	Alliance, Ohio	07137	Transistor Electronics Corp.	Minneapolis, Minn.
01538	Small Parts Inc.	Los Angeles, Cal.	07138	Westinghouse Electric Corp., Electronic Tube Div.	Elmira, N.Y.
01589	Pacific Relays, Inc.	Van Nuys, Cal.	07149	Filmohm Corp.	New York, N.Y.
01670	Gudebrod Bros. Silk Co.	New York, N.Y.	07233	Cinch-Graphik Co.	City of Industry, Cal.
01930	Amerock Corp.	Rockford, Ill	07256	Silicon Transistor Corp.	Carle Place, N.Y.
01960	Pulse Engineering Co.	Santa Clara, Cal.	07261	Avnet Corp.	Culver City, Cal.
02114	Ferrocube Corp. of America	Saugerties, N.Y.	07263	Fairchild Camera & Inst. Corp., Semiconductor Div.	Mountain View, Cal.
02116	Wheelock Signals, Inc.	Long Branch, N.J.	07322	Minnesota Rubber Co.	Minneapolis, Minn.
02286	Cole Rubber and Plastics Inc.	Sunnyvale, Cal.	07387	Birtcher Corp, The	Monterey Park, Cal.
02660	Amphenol-Borg Electronics Corp.	Broadview, Ill.	07397	Sylvania Elect. Prod. Inc., Mt. View Operations	Mountain View, Cal.
02735	Radio Corp. of America, Semiconductor and Materials Division	Somerville, N.J.	07700	Technical Wire Products Inc.	Cranford, N.J.
02771	Vocaline Co. of America, Inc.	Old Saybrook, Conn.	07829	Bodine Elect. Co.	Chicago, Ill.
02777	Hopkins Engineering Co.	San Fernando, Cal.	07910	Continental Device Corp.	Hawthorne, Cal.
02875	Hudson Tool & Die	Newark, N.J.	07933	Raytheon Mfg. Co., Semiconductor Div.	Mountain View, Cal.
03508	G.E. Semiconductor Prod. Dept.	Syracuse, N.Y.	07980	Hewlett-Packard Co., Boonton Radio Div.	Rockaway, N.J.
03705	Apex Machine & Tool Co.	Dayton, Ohio	08145	U.S. Engineering Co.	Los Angeles, Cal.
03797	Eldema Corp.	Compton, Calif.	08289	Blinn, Delbert Co.	Pomona, Cal.
03818	Parker Seal Co.	Los Angeles, Cal.	08358	Burgess Battery Co.	Niagara Falls, Ontario, Canada
03877	Transitron Electric Corp.	Wakefield, Mass.	08524	Deutsch Fastener Corp.	Los Angeles, Cal.
03888	Pyrofilm Resistor Co., Inc.	Cedar Knolls, N.J.	08664	Bristol Co., The	Waterbury, Conn.
03954	Singer Co., Diehl Div., FINDERNE PLANT	Sumerville, N.J.	08717	Sloan Company	Sun Valley, Cal.
04009	Arrow, Hart and Hegeman Elect. Co.	Hartford, Conn.	08718	ITT Cannon Electric Inc., Phoenix Div.	Phoenix, Arizona
04013	Taruus Corp.	Lambertville, N.J.	08727	National Radio Lab. Inc.	Paramus, N.J.
04062	Arco Electronic Inc.	Great Neck, N.Y.	08792	CBS Electronics Semiconductor Operations, Div. of CBS Inc.	Lowell, Mass.
04217	Essex Wire	Los Angeles, Cal.	08806	General Electric Co., Miniature Lamp Dept.	Cleveland, Ohio
04222	Hi-Q Division of Aerovox	Myrtle Beach, S.C.	08984	Mel-Rain	Indianapolis, Ind.
04354	Precision Paper Tube Co.	Wheeling, Ill.	09026	Babcock Relays Div.	Costa Mesa, Cal.
04404	Dymec Division of Hewlett-Packard Co.	Palo Alto, Cal.	09134	Texas Capacitor Co.	Houston, Texas
04651	Sylvania Electric Products, Microwave Device Div.	Mountain View, Cal.	09145	Tech. Ind. Inc. Atohm Elect.	Burbank, Cal.
04673	Dakota Engr. Inc.	Culver City, Cal.	09250	Electro Assemblies, Inc.	Chicago, Ill.
04713	Motorola Inc, Semiconductor Prod. Div.	Phoenix, Arizona	09353	C & K Components Inc.	Newton, Mass.
04732	Filtron Co., Inc. Western Div.	Culver City, Cal.	09569	Mallory Battery Co. of Canada, Ltd.	Toronto, Ontario, Canada
04773	Automatic Electric Co.	Northlake, Ill.	09922	Burndy Corp.	Norwalk, Conn.
04796	Sequoia Wire Co.	Redwood City, Cal.	10214	General Transistor Western Corp.	Los Angeles, Cal.
04811	Precision Coil Spring Co.	El Monte, Cal.			
04870	P. M. Motor Company	Westchester, Ill.			
04919	Component Mfg. Service Co.	W. Bridgewater, Mass.			
05006	Twentieth Century Plastics, Inc.	Los Angeles, Cal.			
05277	Westinghouse Electric Corp. Semiconductor Dept.	Youngwood, Pa.			

00015-46
Revised: October 1969

From: Handbook Supplements
H4-1 Dated AUGUST 1966

Table 6-5. Code List of Manufacturers (Cont.)

Code No.	Manufacturer	Address	Code No.	Manufacturer	Address
10411	Ti-Tal, Inc.	Berkeley, Cal.	19589	Concoa	Baldwin Park, Cal.
10646	Carborundum Co.	Niagara Falls, N.Y.	19644	LRC Electronics	Horseheads, N.Y.
11236	CTS of Berne, Inc.	Berne, Ind.	19701	Electra Mfg. Co.	Independence, Kansas
11237	Chicago Telephone of California, Inc.	So. Pasadena, Cal.	20183	General Atronics Corp.	Philadelphia, Pa.
11242	Bay State Electronics Corp.	Waltham, Mass.	21226	Executone, Inc.	Long Island City, N.Y.
11312	Teledyne Inc., Microwave Div.	Palo Alto, Cal.	21355	Fafnr Bearing Co., The	New Britain, Conn.
11314	National Seal	Downey, Cal.	21520	Fansteel Metallurgical Corp.	N. Chicago, Ill.
11453	Precision Connector Corp.	Jamaica, N.Y.	23042	Texscan Corp.	Indianapolis, Ind.
11534	Duncan Electronics Inc.	Costa Mesa, Cal.	23783	British Radio Electronics Ltd.	Washington, D.C.
11711	General Instrument Corp., Semiconductor Division, Products Group	Newark, N.J.	24455	G.E. Lamp Division	Nela Park, Cleveland, Ohio
11717	Imperial Electronic, Inc.	Buena Park, Cal.	24655	General Radio Co.	West Concord, Mass.
11870	Melabs, Inc.	Palo Alto, Cal.	24681	Memcor Inc., Comp. Div.	Huntington, Ind.
12136	Philadelphia Handle Co.	Camden, N.J.	26365	Gries Reproducer Corp.	New Rochelle, N.Y.
12361	Grove Mfg. Co., Inc.	Shady Grove, Pa.	26462	Grobert File Co. of America, Inc.	Carlstadt, N.J.
12574	Gulton Ind. Inc., Data System Div.	Albuquerque, N.M.	26851	Campac/Hollister Co.	Hollister, Cal.
12697	Clarostat Mfg. Co.	Dover, N.H.	26992	Hamilton Watch Co.	Lancaster, Pa.
12728	Elmar Filter Corp.	W. Haven, Conn.	28480	Hewlett-Packard Co.	Palo Alto, Cal.
12859	Nippon Electric Co., Ltd.	Tokyo, Japan	28520	Heyman Mfg. Co.	Kenilworth, N.J.
12881	Metex Electronics Corp.	Clark, N.J.	30817	Instrument Specialties Co., Inc.	Little Falls, N.J.
12930	Delta Semiconductor Inc.	Newport Beach, Cal.	33173	G.E. Receiving Tube Dept.	Owensboro, Ky.
12954	Dickson Electronics Corp.	Scottsdale, Arizona	35434	Lectrohm Inc.	Chicago, Ill.
13019	Airco Supply Co., Inc.	Witchita, Kansas	36196	Stanwyck Coil Products, Ltd.	Hawkeshury, Ontario, Canada
13103	Thermolloy	Dallas, Texas	36287	Cunningham, W.H. & Hill, Ltd.	Toronto, Ontario, Canada
13396	Telefunken (GmbH)	Hanover, Germany	37942	P.R. Mallory & Co., Inc.	Indianapolis, Ind.
13835	Midland-Wright Div. of Pacific Industries, Inc.	Kansas City, Kansas	39543	Mechanical Industries Prod. Co.	Akron, Ohio
14099	Sem-Tech	Newbury Park, Cal.	40920	Miniature Precision Bearings, Inc.	Keene, N.H.
14193	Calif. Resistor Corp.	Santa Monica, Cal.	42190	Muter Co.	Chicago, Ill.
14298	American Components, Inc.	Conshohocken, Pa.	43990	C.A. Norgren Co.	Englewood, Colo.
14433	ITT Semiconductor, A Div. of Int. Telephone & Telegraph Corporation	West Palm Beach, Fla.	44655	Ohmite Mfg. Co.	Skokie, Ill.
14493	Hewlett-Packard Company	Loveland, Colo.	46384	Penn Eng. & Mfg. Corp.	Doylestown, Pa.
14655	Cornell Dublier Electric Corp.	Newark, N.J.	47904	Polaroid Corp.	Cambridge, Mass.
14674	Corning Glass Works	Corning, N.Y.	48620	Precision Thermometer & Inst. Co.	Southampton, Pa.
14752	Electro Cube Inc.	San Gabriel, Cal.	49956	Microwave & Power Tube Div.	Waltham, Mass.
14960	Williams Mfg. Co.	San Jose, Cal.	52090	Rowan Controller Co.	Westminster, Md.
15106	The Sphere Co., Inc.	Little Falls, N.J.	52983	Sanborn Company	Waltham, Mass.
15203	Wehster Electronics Co.	New York, N.Y.	54294	Shallcross Mfg. Co.	Selma, N.C.
15287	Scionics Corp.	Northridge, Cal.	55026	Simpson Electric Co.	Chicago, Ill.
15291	Adjustable Bushing Co.	N. Hollywood, Cal.	55933	Sonotone Corp.	Elmsford, N.Y.
15558	Micron Electronics	Garden City, Long Island, N.Y.	55938	Raytheon Co. Commercial Apparatus & System Div.	So. Norwalk, Conn.
15566	Amprobe Inst. Corp.	Lynbrook, N.Y.	56137	Spaulding Fibre Co., Inc.	Tonawanda, N.Y.
15631	Cabletronics	Costa Mesa, Cal.	56289	Sprague Electric Co.	North Adams, Mass.
15772	Twentieth Century Coil Spring Co.	Santa Clara, Cal.	59446	Cablex Corp.	Tulsa, Okla.
15801	Fenwal Elect. Inc.	Framingham, Mass.	59730	Thomas & Betts Co.	Elizabeth, N.J.
15818	Amelco Inc.	Mountain View, Cal.	60741	Triplett Electrical Inst. Co.	Bluffton, Ohio
16037	Spruce Pine Mica Co.	Spruce Pine, N.C.	61775	Union Switch and Signal, Div. of Westinghouse Air Brake Co.	Pittsburgh, Pa.
16179	Omni-Spectra Inc.	Detroit, Ill.	62119	Universal Electric Co.	Owosso, Mich.
16352	Computer Diode Corp.	Lodi, N.J.	63743	Ward-Leonard Electric Co.	Mt. Vernon, N.Y.
16585	Boots Aircraft Nut Corp.	Pasadena, Cal.	64959	Western Electric Co., Inc.	New York, N.Y.
16688	Ideal Prec. Meter Co., Inc., De Jur Meter Div.	Brooklyn, N.Y.	65092	Weston Inst. Inc. Weston-Newark	Newark, N.J.
16758	Delco Radio Div. of G.M. Corp.	Kokoma, Ind.	66295	Witteck Mfg. Co.	Chicago, Ill.
17109	Thermonetics Inc.	Canoga Park, Cal.	66346	Minnesota Mining & Mfg. Co. Revere Mincom Div.	St. Paul, Minn.
17474	Tranex Company	Mountain View, Cal.	70276	Allen Mfg. Co.	Hartford, Conn.
17675	Hamlin Metal Products Corp.	Akron, Ohio	70309	Allied Control	New York, N.Y.
17745	Angstrom Prec. Inc.	No. Hollywood, Cal.	70318	Allmetal Screw Product Co., Inc.	Garden City, N.Y.
17856	Siliconix Inc.	Sunnyvale, Cal.	70417	Aplex, Div. of Chrysler Corp.	Detroit, Mich.
17870	McGraw-Edison Co.	Manchester, N.H.	70485	Atlantic India Rubber Works, Inc.	Chicago, Ill.
18042	Power Design Pacific Inc.	Palo Alto, Cal.	70563	Amperite Co., Inc.	Union City, N.J.
18083	Clevite Corp., Semiconductor Div.	Palo Alto, Cal.	70674	ADC Products Inc.	Minneapolis, Minn.
18324	Signetics Corp.	Sunnyvale, Cal.	70903	Belden Mfg. Co.	Chicago, Ill.
18476	Ty-Car Mfg. Co., Inc.	Holliston, Mass.	70998	Bird Electric Corp.	Cleveland, Ohio
18486	TRW Elect. Comp. Div.	Des Plaines, Ill.	71002	Birnbach Radio Co.	New York, N.Y.
18583	Curtis Instrument, Inc.	Mt. Kisco, N.Y.	71034	Biley Electric Co., Inc.	Erie, Pa.
18612	Vishay Instruments Inc.	Malvern, Pa.	71041	Boston Gear Works Div. of Murray Co. of Texas	Quincey, Mass.
18873	E.I. DuPont and Co., Inc.	Wilmington, Del.	71218	Bud Radio, Inc.	Willoughby, Ohio
18911	Durant Mfg. Co.	Milwaukee, Wis.	71279	Cambridge Thermionics Corp.	Cambridge, Mass.
19315	The Bendix Corp., Navigation & Control Div.	Teterboro, N.J.	71286	Camloc Fastener Corp.	Paramus, N.J.
19500	Thomas A. Edison Industries, Div. of McGraw-Edison Co.	West Orange, N.J.	71313	Cardwell Condenser Corp.	Lindenhurst, L.I., N.Y.
			71400	Bussmann Mfg. Div. of McGraw-Edison Co.	St. Louis, Mo.

00015-46
Revised: October 1969

From: Handbook Supplements
H4-1 Dated AUGUST 1966

Table 6-5. Code List of Manufacturers (Cont.)

Code No.	Manufacturer	Address	Code No.	Manufacturer	Address
71436	Chicago Condenser Corp.	Chicago, Ill.	77764	Resistance Products Co.	Harrisburg, Pa.
71447	Calif. Spring Co., Inc.	Pico-Rivera, Cal.	77969	Rubbercraft Corp. of Calif.	Torrance, Cal.
71450	CTS Corp.	Elkhart, Ind.	78189	Shakeproof Division of Illinois Tool Works	Elgin, Ill.
71468	ITT Cannon Electric Inc.	Los Angeles, Cal.	78277	Sigma	So. Braintree, Mass.
71471	Cinema, Div. Aerovox Corp.	Burbank, Cal.	78283	Signal Indicator Corp.	New York, N.Y.
71482	C.P. Clare & Co.	Chicago, Ill.	78290	Struthers-Dunn Inc.	Pitman, N.J.
71590	Centralab Div. of Globe Union Inc.	Milwaukee, Wis.	78452	Thompson-Bremer & Co.	Chicago, Ill.
71616	Commercial Plastics Co.	Chicago, Ill.	78471	Tilley Mfg. Co.	San Francisco, Cal.
71700	Cornish Wire Co., The	New York, N.Y.	78488	Stackpole Carbon Co.	St. Marys, Pa.
71707	Coto Coil Co., Inc.	Providence, R.I.	78493	Standard Thomson Corp.	Waltham, Mass.
71744	Chicago Miniature Lamp Works	Chicago, Ill.	78553	Tinnerman Products, Inc.	Cleveland, Ohio
71785	Cinch Mfg. Co., Howard B. Jones Div.	Chicago, Ill.	78790	Transformer Engineers	San Gabriel, Cal.
71984	Dow Corning Corp.	Midland, Mich.	78947	Ucinite Co.	Newtonville, Mass.
72136	Electro Motive Mfg. Co., Inc.	Willimantic, Conn.	79136	Waldes Kohinoor Inc.	Long Island City, N.Y.
72619	Dialight Corp.	Brooklyn, N.Y.	79142	Veeder Root, Inc.	Hartford, Conn.
72656	Indiana General Corp., Electronics Div.	Keasby, N.J.	79251	Avery Mfg. Co.	Chicago, Ill.
72699	General Instrument Corp., Cap. Div.	Newark, N.J.	79727	Continental-Wirt Electronics Corp.	Philadelphia, Pa.
72765	Drake Mfg. Co.	Harwood Heights, Ill.	79963	Zierick Mfg. Corp.	New Rochelle, N.Y.
72825	Hugh H. Eby Inc.	Philadelphia, Pa.	80031	Meppo Division of Sessions Clock Co.	Morristown, N.J.
72928	Gudeman Co.	Chicago, Ill.	80033	Prestole Corp.	Toledo, Ohio
72962	Elastic Stop Nut Corp.	Union, N.J.	80120	Schnitzer Alloy Products Co.	Elizabeth, N.J.
72964	Robert M. Hadley Co.	Los Angeles, Cal.	80131	Electronic Industries Association, Any Brand Tube meeting EIA Standards-Washington, D.C.	
72982	Erie Technological Products, Inc.	Erie, Pa.	80207	Unimax Switch, Div. Maxon Electronics Corp.	
73061	Hansen Mfg. Co., Inc.	Princeton, Ind.			Wallingford, Conn.
73076	H.M. Harper Co.	Chicago, Ill.	80223	United Transformer Corp.	New York, N.Y.
73138	Helipot Div. of Beckman Inst. Inc.	Fullerton, Cal.	80248	Oxford Electric Corp.	Chicago, Ill.
73293	Hughes Products Division of Hughes Aircraft Co.		80294	Bourns Inc.	Riverside, Cal.
		Newport Beach, Cal.	80411	Arco Div. of Robertshaw Controls Co.	Columbus, Ohio
73445	Amperex Elect. Co.	Hicksville, L.I., N.Y.	80486	All Star Products Inc.	Defiance, Ohio
73506	Bradley Semiconductor Corp.	New Haven, Conn.	80509	Avery Label Co.	Monrovia, Cal.
73559	Carling Electric, Inc.	Hartford, Conn.	80583	Hammarlund Co., Inc.	Mars Hill, N.C.
73586	Circle F Mfg. Co.	Trenton, N.J.	80640	Stevens, Arnold, Co., Inc.	Boston, Mass.
73682	George K. Garrett Co., Div. MSL Industries Inc.		80813	Dimco Gray Co.	Dayton, Ohio
		Philadelphia, Pa.	81030	International Instruments Inc.	Orange, Conn.
73734	Federal Screw Products Inc.	Chicago, Ill.	81073	Grayhill Co.	LaGrange, Ill.
73743	Fischer Special Mfg. Co.	Cincinnati, Ohio	81095	Triad Transformer Corp.	Venice, Cal.
73793	General Industries Co., The	Elyria, Ohio	81312	Winchester Elec. Div. Litton Ind., Inc.	Oakville, Conn.
73846	Goshen Stamping & Tool Co.	Goshen, Ind.	81349	Military Specification	
73899	JFD Electronics Corp.	Brooklyn, N.Y.	81483	International Rectifier Corp.	El Sugundo, Cal.
73905	Jennings Radio Mfg. Corp.	San Jose, Cal.	81541	Airpax Electronics, Inc.	Cambridge, Maryland
73957	Groove-Pin Corp.	Ridgefield, N.J.	81860	Barry Controls, Div. Barry Wright Corp.	
74276	Signalite Inc.	Neptune, N.J.			Watertown, Mass.
74455	J.H. Winns, and Sons	Winchester, Mass.	82042	Carter Precision Electric Co.	Skokie, Ill.
74861	Industrial Condenser Corp.	Chicago, Ill.	82047	Sperti Faraday Inc., Copper Hewitt Electric Div.	
74868	R.F. Products Division of Amphenol-Borg Electronics Corp.				Hoboken, N.J.
		Danbury, Conn.	82116	Electric Regulator Corp.	Norwalk, Conn.
74970	E.F. Johnson Co.	Waseca, Minn.	82142	Jeffers Electronics Division of Speer Carbon Co.	
75042	International Resistance Co.	Philadelphia, Pa.			Du Bois, Pa.
75263	Keystone Carbon Co., Inc.	St. Marys, Pa.	82170	Fairchild Camera & Inst. Corp., Space & Defense Systems Div.	Paramus, N.J.
75378	CTS Knights Inc.	Sandwich, Ill.	82209	Magurie Industries, Inc.	Greenwich, Conn.
75382	Kulka Electric Corporation	Mt. Vernon, N.Y.	82219	Sylvania Electric Prod. Inc., Electronic Tube Division	
75818	Lenz Electric Mfg. Co.	Chicago, Ill.			Emporium, Pa.
75915	Littlefuse, Inc.	Des Plaines, Ill.	82376	Astron Corp.	East Newark, Harrison, N.J.
76005	Lord Mfg. Co.	Erie, Pa.	82389	Switchcraft, Inc.	Chicago, Ill.
76210	C.W. Marwedel	San Francisco, Cal.	82647	Metals & Controls Inc., Spencer Products	
76433	General Instrument Corp., Micamold Division				Attleboro, Mass.
		Newark, N.J.	82768	Phillips-Advance Control Co.	Joliet, Ill.
76487	James Millen Mfg. Co., Inc.	Malden, Mass.	82866	Research Products Corp.	Madison, Wis.
76493	J.W. Miller Co.	Los Angeles, Cal.	82877	Roltron Mfg. Co., Inc.	Woodstock, N.Y.
76530	Cinch-Monadnock, Div. of United Carr Fastener Corp.		82893	Vector Electronic Co.	Glendale, Cal.
		San Leandro, Cal.	83058	Carr Fastener Co.	Cambridge, Mass.
76545	Mueller Electric Co.	Cleveland, Ohio	83086	New Hampshire Ball Bearing, Inc.	Peterborough, N.H.
76703	National Union	Newark, N.J.	83125	General Instrument Corp., Capacitor Div.	
76854	Oak Manufacturing Co.	Crystal Lake, Ill.			Darlington, S.C.
77068	The Bendix Corp., Electroynamics Div.		83148	ITT Wire and Cable Div.	Los Angeles, Cal.
		N. Hollywood, Cal.	83186	Victory Eng. Corp.	Springfield, N.J.
77075	Pacific Metals Co.	San Francisco, Cal.	83298	Bendix Corp., Red Bank Div.	Red Bank, N.J.
77221	Phanostran Instrument and Electronic Co.		83315	Hubbell Corp.	Mundelein, Ill.
		So. Pasadena, Cal.	83324	Rosan Inc.	Newport Beach, Cal.
77252	Philadelphia Steel and Wire Corp.	Philadelphia, Pa.	83330	Smith, Herman H., Inc.	Brooklyn, N.Y.
77342	American Machine & Foundry Co. Potter & Brumfield Div.	Princeton, Ind.	83332	Tech Labs	Palisades Park, N.J.
77630	TRW Electronic Components Div.	Camden, N.J.	83385	Central Screw Co.	Chicago, Ill.
77638	General Instrument Corp., Rectifier Div.	Brooklyn, N.Y.			

Table 6-5. Code List of Manufacturers (Cont.)

Code No.	Manufacturer	Address	Code No.	Manufacturer	Address
83501	Gavitt Wire and Cable Co., Div. of Amerace Corp.	Brookfield, Mass.	94144	Raytheon Co., Comp. Div., Ind. Comp. Operations	Quincy, Mass.
83594	Burroughs Corp Electronic Tube Div.	Plainfield, N.J.	94148	Scientific Electronics Products, Inc.	Loveland, Colo.
83740	Union Carbide Corp. Consumer Prod. Div.	New York, N.Y.	94154	Wagner Elect. Corp., Tung-Sol Div.	Newark, N.J.
83777	Model Eng. and Mfg., Inc.	Huntington, Ind.	94197	Curtiss-Wright Corp. Electronics Div.	East Patterson, N.J.
83821	Loyd Scruggs Co.	Festus, Mo.	94222	South Chester Corp.	Chester, Pa.
83942	Aeronautical Inst. & Radio Co.	Lodi, N.J.	94330	Wire Cloth Products, Inc.	Bellwood, Ill.
84171	Arco Electronics Inc.	Great Neck, N.Y.	94375	Automatic Metal Products Co.	Brooklyn, N.Y.
84396	A.J. Glesener Co., Inc.	San Francisco, Cal.	94682	Worcester Pressed Aluminum Corp.	Worcester, Mass.
84411	TRW Capacitor Div.	Ogallala, Neb.	94696	Magnecraft Electric Co.	Chicago, Ill.
84970	Sarkes Tarzian, Inc.	Bloomington, Ind.	95023	George A. Philbrick Researchers, Inc.	Boston, Mass.
85454	Boonton Molding Company	Boonton, N.J.	95236	Allies Products Corp.	Dania, Fla.
85471	A.B. Boyd Co.	San Francisco, Cal.	95238	Continental Connector Corp.	Woodside, N.Y.
85474	R.M. Bracamonte & Co.	San Francisco, Cal.	95263	Leecraft Mfg. Co., Inc.	Long Island, N.Y.
85660	Koiled Kords, Inc.	Hamden, Conn.	95265	National Coil Co.	Sheridan, Wyo.
85911	Seamless Rubber Co.	Chicago, Ill.	95275	Vitramon, Inc.	Bridgeport, Conn.
86174	Fafnir Bearing Co.	Los Angeles, Calif.	95348	Gordos Corp.	Bloomfield, N.J.
86197	Clifton Precision Products Co., Inc.	Clifton Heights, Pa.	95354	Methode Mfg. Co.	Rolling Meadows, Ill.
86579	Precision Rubber Products Corp.	Dayton, Ohio	95566	Arnold Engineering Co.	Marengo, Ill.
86684	Radio Corp. of America, Electronic Comp. & Devices Div.	Harrison, N.J.	95712	Dage Electric Co., Inc.	Franklin, Ind.
86928	Seastrom Mfg. Co.	Glendale, Cal.	95984	Simon Mfg. Co.	Wayne, Ill.
87034	Marco Industries	Anaheim, Cal.	95987	Weckesser Co.	Chicago, Ill.
87216	Philco Corporation (Lansdale Division)	Lansdale, Pa.	96067	Microwave Assoc., West Inc.	Sunnyvale, Cal.
87473	Western Fibrous Glass Products Co.	San Francisco, Cal.	96095	Hi-Q Div. of Aerovox Corp.	Olean, N.Y.
87664	Van Waters & Rogers Inc.	San Francisco, Cal.	96256	Thordarson-Meissner Inc.	Mt. Carmel, Ill.
87930	Tower Mfg. Corp.	Providence, R.I.	96296	Solar Manufacturing Co.	Los Angeles, Cal.
88140	Cutler-Hammer, Inc.	Lincoln, Ill.	96396	Microswitch, Div. of Minn.-Honeywell	Freeport, Ill.
88220	Gould-National Batteries, Inc.	St. Paul, Minn.	96330	Carlton Screw Co.	Chicago, Ill.
88698	General Mills, Inc.	Buffalo, N.Y.	96341	Microwave Associates, Inc.	Burlington, Mass.
89231	Graybar Electric Co.	Oakland, Cal.	96501	Excel Transformer Co.	Oakland, Cal.
89473	G.E. Distributing Corp.	Schenectady, N.Y.	96508	Xcelite Inc.	Orchard Park, N.Y.
89665	United Transformer Co.	Chicago, Ill.	96733	San Fernando Elect. Mfg. Co.	San Fernando, Cal.
90030	United Shoe Machinery Corp.	Beverly, Mass.	96881	Thomson Ind. Inc.	Long Island, N.Y.
90179	U S Rubber Co., Consumer Ind. & Plastics Prod. Div.	Passaic, N.J.	97464	Industrial Retaining Ring Co.	Irvington, N.J.
90763	United Carr Fastener Corp	Chicago, Ill.	97539	Automatic & Precision Mfg.	Englewood, N.J.
90970	Bearing Engineering Co.	San Francisco, Cal.	97979	Reon Resistor Corp.	Yonkers, N.Y.
91146	ITT Cannon Elect. Inc., Salem Div.	Salem, Mass.	97983	Litton System Inc., Adler-Westrex Commun. Div.	New Rochelle, N.Y.
91260	Connor Spring Mfg. Co.	San Francisco, Cal.	98141	R-Tronics, Inc.	Jamaica, N.Y.
91345	Miller Dial & Nameplate Co.	El Monte, Cal.	98159	Rubber Teck, Inc.	Gardena, Cal.
91418	Radio Materials Co.	Chicago, Ill.	98220	Hewlett-Packard Co., Moseley Div.	Pasadena, Cal.
91506	Augat Inc.	Attleboro, Mass.	98278	Microdot, Inc.	So. Pasadena, Cal.
91637	Dale Electronics, Inc.	Columbus, Nebr.	98291	Sealectro Corp.	Mamaronech, N.Y.
91662	Elco Corp.	Willow Grove, Pa.	98376	Zero Mfg. Co.	Burbank, Cal.
91737	Gremar Mfg. Co., Inc.	Wakefield, Mass.	98410	Etc Inc.	Cleveland, Ohio
91827	K F Development Co.	Redwood City, Cal.	98731	General Mills Inc., Electronics Div.	Minneapolis, Minn.
91886	Malco Mfg. Co., Inc.	Chicago, Ill.	98734	Paeco Div. of Hewlett-Packard Co.	Palo Alto, Cal.
91929	Honeywell Inc., Micro Switch Div.	Freeport, Ill.	98821	North Hills Electronics, Inc.	Glen Cove, N.Y.
91961	Nahm-Bros, Spring Co.	Oakland, Cal.	98978	International Electronic Research Corp.	Burbank, Cal.
92180	Tru-Connector Corp.	Peabody, Mass.	99109	Columbia Technical Corp.	New York, N.Y.
92367	Elgeet Optical Co., Inc.	Rochester, N.Y.	99313	Varian Associates	Palo Alto, Cal.
92607	Tensolite Insulated Wire Co., Inc.	Tarrytown, N.Y.	99378	Atlee Corp.	Winchester, Mass.
92702	IMC Magnetics Corp.	Westbury, Long Island, N.Y.	99515	Marshall Ind., Capacitor Div.	Monrovia, Cal.
92966	Hudson Lamp Co.	Kearney, N.J.	99707	Control Switch Division, Controls Co. of America	El Segundo, Cal.
93332	Sylvania Electric Prod. Inc., Semiconductor Div.	Woburn, Mass.	99800	Delevan Electronics Corp.	East Aurora, N.Y.
93369	Robbins & Myers Inc.	Pallisades Park, N.J.	99848	Wilco Corporation	Indianapolis, Ind.
93410	Stemco Controls, Div. of Essex Wire Corp.	Mansfield, Ohio	99928	Branson Corp.	Whippany, N.J.
93632	Waters Mfg. Co.	Culver City, Cal.	99934	Rembrandt, Inc.	Boston, Mass.
93929	G.V. Controls	Livingston, N.J.	99942	Hoffman Electronics Corp., Semiconductor Div.	El Monte, Cal.
94137	General Cable Corp.	Bayonne, N.J.	99957	Technology Instrument Corp. of Calif.	Newbury Park, Cal.

The following HP Vendors have no number assigned in the latest supplement to the Federal Supply Code for Manufacturers Handbook.

0000F	Malco Tool and Die	Los Angeles, Calif.	000MM	Rubber Eng. & Development	Hayward, Cal.
0000Z	Willow Leather Products Corp.	Newark, N.J.	000NN	A "N" D Mfg. Co.	San Jose, Cal.
000AB	ETA	England	000QQ	Cooltron	Oakland, Cal.
000BB	Precision Instrument Components Co.	Van Nuys, Cal.	000WW	California Eastern Lab	Burlington, Cal.
000CS	Hewlett-Packard Co., Colorado Springs	Colorado Springs, Colorado	000YY	S.K. Smith Co.	Los Angeles, Cal.

00015-45
Revised: October 1969

From: Handbook Supplements
H4-1 Dated AUGUST 1966

SECTION VII MANUAL CHANGES

7-1. INTRODUCTION.

7-2. This section will be used in future issues or revisions of this manual to provide up-dating and back-dating information.

7-3. In the interim, any necessary changes to the information contained in this manual will be documented in Manual Change Sheets shipped with the manual.

MANUAL CHANGES

MANUAL IDENTIFICATION

Model Number: 8443A
Date Printed: June 1970
Part Number: 08443-90009

This supplement contains important information for correcting manual errors and for adapting the manual to instruments containing improvements made after the printing of the manual.

To use this supplement:

Make all ERRATA corrections

Make all appropriate serial number related changes indicated in the tables below.

Serial Prefix or Number	Make Manual Changes	Serial Prefix or Number	Make Manual Changes
All	Errata		
964-00220	1		
104900271	2		

► NEW ITEM

ERRATA

Page 1-3, Table 1-2, Test Equipment and Accessories:
Change Oscilloscope Sensitivity to 0.020 V/div.

Page 1-4, Table 1-2, Test Equipment and Accessories:
Add Recorder paper Std 5" rollchart 50 minor divisions HP 9270-1012 to Digital to Analog Converter/Recorder.
Change Attenuator from HP 355D to HP H38-355D and accuracy to 0.01 dB.
Add Attenuator HP H38-355C Range 1.2 dB in 0.1 steps accuracy 0.01 dB.

Page 1-5, Table 1-2, Test Equipment and Accessories:
Change AC Voltmeter Frequency Range to 20 Hz to 4 MHz.
Change last item, suggested model, to HP 7035B.

Page 2-1, Paragraph 2-15:
Change to read: Forced air cooling is provided by a cooling fan located in the A1 assembly.

Page 4-3, Figure 4-2:
Add: The low pass filter should be connected to the next higher output on the analyzer (Vertical Output). This filter consists of a 100 μ F capacitor across the digital voltmeter terminals. (The resistor in the low pass filter detail is representative of the output impedance of the analyzer vertical output.)

Page 4-7:
Change under X-Y RECORDER, words Vertical and Horizontal are reversed (first word in two paragraphs).
Figure 4-3:
Change Bandpass Filter, 10K resistor is the input.

NOTE

Manual change supplements are revised as often as necessary to keep manuals as current and accurate as possible. Hewlett-Packard recommends that you periodically request the latest edition of this supplement. Free copies are available from all HP offices. When requesting copies quote the manual identification information from your supplement, or the model number and print date from the title page of the manual.

16 April 1971

HEWLETT  PACKARD

Printed in U.S.A.

Page 4-8:

Change SPECIFICATION sentence to end ; output 0 dBm.

Page 4-10, Paragraph 4-17:

Change SPECIFICATION to read: $<3 \times 10^{-9}$ per day (0.003 Hz/day at 1 MHz after warmup).

Page 4-11:

Delete by AMPLIFIER "to 1 MHz"

Add GAIN x 10.

Figure 4-5: Change figure as shown.

Page 4-12:

Paragraph 4-17, step 4, change three minor divisions to 1.5 minor divisions.

Paragraph 4-18, change SPECIFICATION to read $<3 \times 10^6$ (0.03 Hz) variation referenced to 100 MHz 0 – 55° C.

Page 5-4, paragraph 5-14, step 5:

Delete first sentence and change Test Point 4 to Test Point 1.

Page 5-8, paragraph 5-19:

Change Steps 3 and 6 to read "set TENTHS to 1.0" (not .1).

Change Steps 3, 4 and 5 ONES to UNITS.

Page 6-1, Table 6-1:

Change A1 part number to 08443-60071.

Page 6-3, Table 6-3:

Change A1 part number to 08443-60071.

Page 6-15, Table 6-3:

Add A9W1 08443-60058 Cable Assy, Green.

Add A9W2 08443-60057 Cable Assy, Violet.

Page 6-18, Table 6-3:

Change A11R20 to 51.1 ohms 1% 1 each, part number 0757-0394.

Change A11R19 and A11R21 to 121 ohms 1% 2 each, part number 0757-0403.

Page 6-23:

Change C6, C7, C8 and C9 part number to 0160-3453.

Page 6-25:

Add A18XA17 Connector PC 36 contact 1251-2026.

Page 6-26, Table 6-3:

Change 08553-6063 description to read "RF Output blocking capacitor assembly".

Page 6-31, Table 6-4:

Add 5040-0031 Absorber, RF 2 each.

Change part number 1970-0042 Total Quantity to 8.

Page 6-32, Table 6-4:

Change part number 9100-2878 to 9100-3121.

Add 08443-00018 Bracket, Regulator Mounting.

Add 08443-60009 Cable Assembly, instrument interconnect.

Page 6-33, Table 6-4:

Change part number 08443-60066 to 08443-60071.

Add 08443-60067 Cable Assembly 24V 1 each.

Add 08443-60068 A17 BCD Assy.

Change description of 08443-60049 to read "Cable, counter interconnect".

Page 8-2, Table 8-1:

Change range of R12 to 3.16K to 4.75K

Page 8-19, Table 8-6A.

Add attached table 8-6A to page 8-19.

Page 8-27, Figure 8-23:
Change A11R19 and A11R21 to 121 ohms.
Change A11R20 to 51.1 ohms.
Change Tracking Adj terminals 5 and E. They are reversed.

Page 8-29, Figure 8-27:
Change L4 (first 1.0 μ H coil in -12V line) to L5.
Add blocking capacitor to output of A3 assembly.

Page 8-31, Figure 8-30:
Change ON-STBY switch to show STBY position grounded. +24 volts used as a reference should be labeled "switched 24V".
Change Q4 to PNP, not NPN as shown.

Page 8-35, Figure 8-33:
Label S1 "Pull to Center" and R13A/B "MARKER POSITION".
Change part number of Q5 to 1854-0221.

Page 8-39, Figure 8-37:
Change values of A6R11 and A6R12. They are reversed.

CHANGE 1

Page 2-1, Paragraph 2-15:
Add cooling fan.

Page 6-3, Table 6-2:
Add attached parts list.

Page 6-9, Table 6-3:
Add A6L12 9100-1630 51 μ H 5%.

Page 8-39, Figure 8-37:
Add L12 between Q4 emitter and Q3 emitter 51 μ H.

Page 8-41:
Add attached figure to A1 Assembly.

Note

The modification to earlier serial numbered instruments is available from HP Service Centers on a warranty basis. The kit part number is 08443-60074.

CHANGE 2

Add a filter to the cooling fan installed as a result of Change 1.
Parts required are: 3150-0214 Filter, Foam 1 each
08443-00048 Retainer, Filter 1 each
Add a label to the instrument for cooling fan filter cleaning.

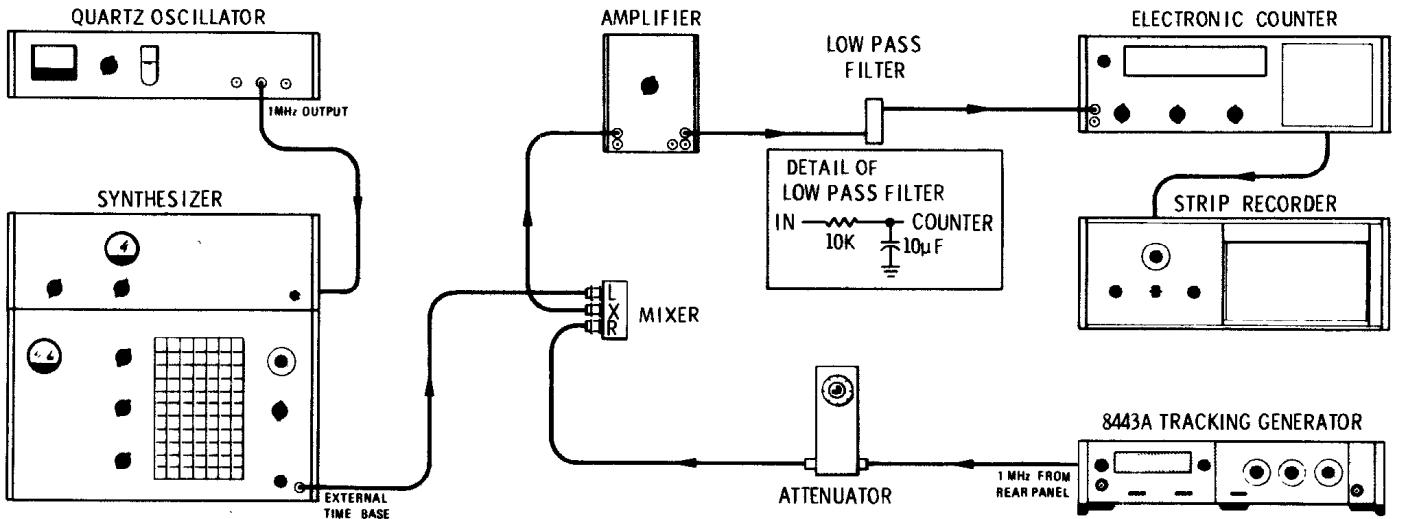
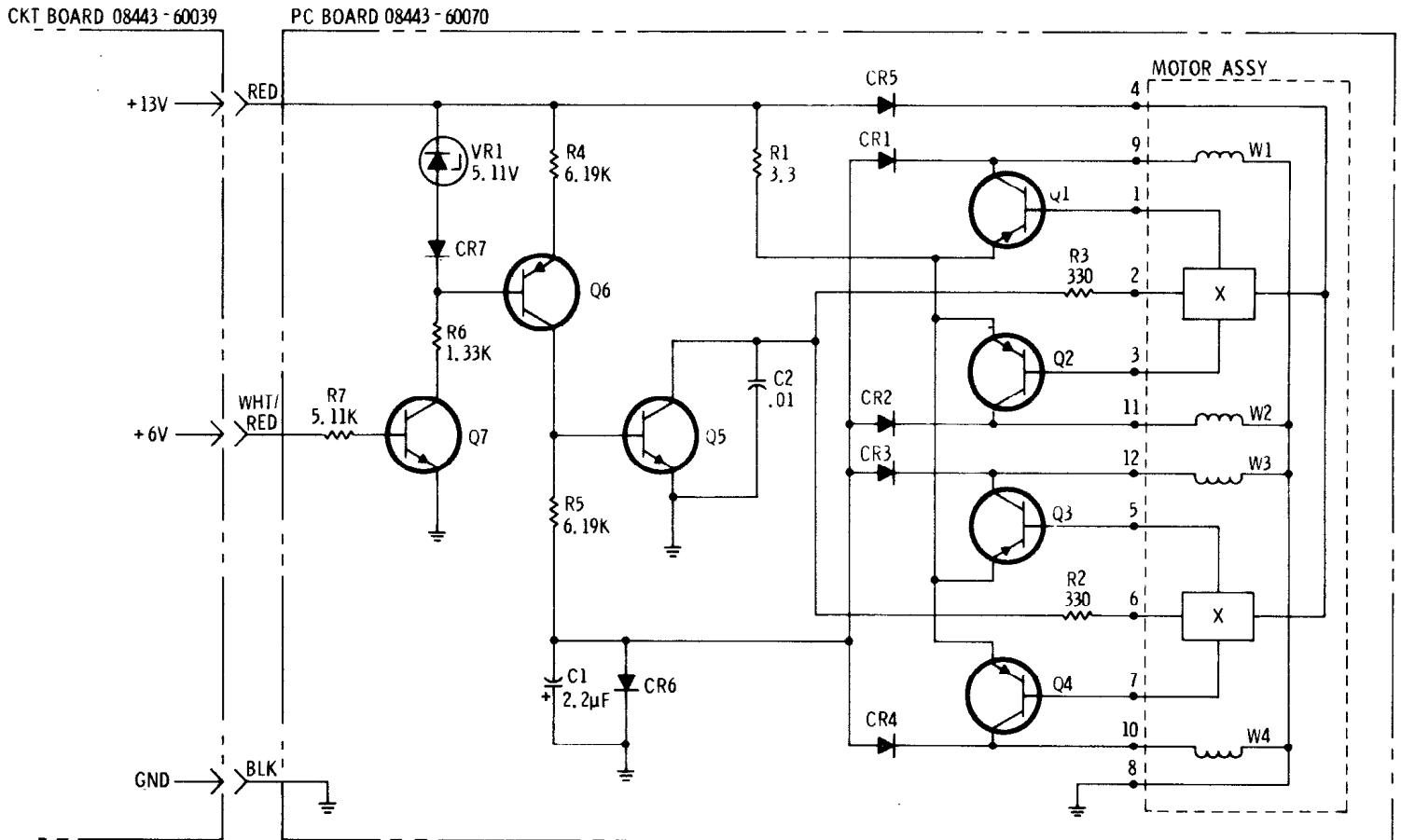

Figure 4-5. Time Base Aging Rate Test



Motor/Driver Circuit Diagram

Table 6-2. Replaceable Parts

Reference Designation	HP Part Number	Qty	Description	Mfr. Code	Manufacturers Part Number
A1A2	08443-60070	1	Bd Assy, Motor and Driver	28480	08443-60070
A1A2C1	0180-0155	1	C:FXD Elect, 2.2 μ F 20% 20 VDCW	56289	150D225X 0020A2
A1A2C2	0160-3451	1	C:FXD Cer, 0.01 μ F +80 -20% 100 VDCW	56289	C023B101F103Z- 525-CDH
A1A2CR1 - 4	1901-0040	6	Diode:SI, 30 WV 30 mA	07263	FDG1088
A1A2CR5	1901-0049	1	Diode:SI, 50 PIV	28480	1901-0049
A1A2CR6, 7	1901-0040		Diode:SI, 30 WV	07263	FDG 1088
A1A2B1	3140-0487	1	Motor:DC	07829	B2246
A1A2Q1 - 4	1853-0027	4	Transistor:SI, PNP	07263	SI554S
A1A2Q5	1854-0045	1	Transistor:SI, NPN	04713	2N956
A1A2Q6	1853-0020	1	Transistor:SI, PNP	28480	1853-0020
A1A2Q7	1854-0071	1	Transistor:SI, NPN	28480	1854-0071
A1A2R1	0683-0335	1	R:FXD, Comp 3.3 ohm, 5%, 1/4W	01121	CB0335
A1A2R2, 3	0684-3311	2	R:FXD, Comp, 330 ohm, 10%, 1/4W	01121	E83311
A1A2R4, 5	0698-7255	2	R:FXD, Film, 6.19K ohm, 2% 1/8W	28480	0698-7255
A1A2R6	0698-7239	1	R:FXD, Film 1.33K ohm, 2% 1/8W	28480	0698-7239
A1A2R7	0698-7253	1	R:FXD, Film, 5.11K ohm, 2%, 1/8W	28480	0698-7253
A1A2CR1	1902-2094	1	Diode:Breakdown, 5.11V, 2%	28480	1902-2094

Signal Path for BCD Information from Low Frequency Counter to Rear Panel

Board						
Low Frequency Counter A1 08443-60037	Connector Board A1A3 08443-60039	Mother Board A18 08443-60016	BCD Board A17 08443-60039			
Signal	XA1A1 Connector Pin No.	XA1 Connector Pin No.	XA17 Connector Pin No.	Digital Output Connector Pin No.		
A0 B0 C0 D0	9 J 8 K	R 15 S 14	5 D 4 E	1 2 26 27	Note Signals A0, B0, C0 and D0 are right-most digit.	
A1 B1 C1 D1	11 10 L M	N P 13 12	7 6 F H	3 4 28 29		
A2 B2 C2 D2	13 N 12 P	L 11 M 10	9 J 8 K	5 6 30 31		
A3 B3 C3 D3	15 R 14 S	J 9 K 8	11 L 10 M	7 8 32 33		
A4 B4 C4 D4	17 T 16 U	F 7 H 6	13 N 12 P	9 10 34 35		
A5 B5 C5 D5	W V 18 19	4 5 E D	S R 14 15	11 12 26 27		
A6 B6 C6 D6	21 X 20 Y	B 3 C 2	17 T 16 U	13 14 38 39		
A7	22	A	18	15		
Blanking	Z	1	V	Blanking Switch	Blanked Unblanked	Gnd +5
Print Inhibit	XA5, 1 XA5, 2		A B	48 22		
+5			1	25, Blanking Switch		
Gnd			2	24, 50, 16, 40, 41, Blanking Switch		

SECTION VIII SERVICE

8-1. INTRODUCTION.

8-2. This section provides instructions for testing, troubleshooting and repairing the HP Model 8443A Tracking Generator/Counter.

8-3. PRINCIPLES OF OPERATION.

8-4. Information relative to the principles of operation appears on the foldout pages opposing the Block Diagrams, Service Sheet 1 for the Tracking Generator and Service Sheet 5 for the Counter Section. This correlation of data will enable the reader to quickly relate functions to specific circuits — without having to look in different parts of the manual.

8-5. RECOMMENDED TEST EQUIPMENT.

8-6. Test equipment and accessories required to maintain the model 8443A are listed in Table 1-2. If the equipment listed is not available, equipment that meets the minimum specifications shown may be substituted.

8-7. TROUBLESHOOTING.

8-8. Troubleshooting procedures are divided into two maintenance levels in this manual. The first,

troubleshooting tree, is designed to isolate the cause of a malfunction to a circuit or assembly.

8-9. The second maintenance level provides circuit analysis and test procedures to aid in isolating faults to a defective component. Circuit descriptions and test procedures for the second maintenance level are located on the page facing the schematic diagram of the circuit to be repaired.

8-10. After the cause of a malfunction has been found and remedied in any circuit containing adjustable components, the applicable procedure specified in Section V of this manual should be performed.

8-11. REPAIR.

8-12. **MODULE EXCHANGE.** For the benefit of those who do not wish to repair at the component level, a module exchange program has been initiated for the Model 8443A. These factory-repaired modules are available at a considerable savings in cost over the cost of a new module.

8-13. These exchange modules should be ordered from the nearest Hewlett-Packard Sales/Service Office using the special part numbers in Table 6-1



Figure 8-1. Model 8443A with Circuit Board Extended for Maintenance

of this manual. Virtually all orders for replacements received by HP offices are shipped the same day received — either from the local office or from a Service Center.

8-14. LINE VOLTAGE REQUIREMENTS. During adjustment and testing the model 8443A must be connected to a source of power capable of delivering 75 watts of power at 115 or 230 volts ac $\pm 10\%$, single phase. If adjustment of the dc voltage regulators is required, the model 8443A should be connected to the ac source through an adjustable auto-transformer. The line voltage to the model 8443A may then be adjusted to check regulator action when the line voltage is changed $\pm 10\%$.

8-15. SERVICING AIDS ON PRINTED CIRCUIT BOARDS. Servicing aids on printed circuit boards include test points, transistor designations, adjustment callouts and assembly stock numbers with alpha-numerical revision information.

8-16. CIRCUIT BOARD EXTENDERS. Circuit board extenders are provided with the Service Kit. These extenders enable the technician to extend the boards clear of the assembly to provide easy access to components and test points. See Figure 8-1 for a typical example of extender board use.

8-17. PART LOCATION AIDS. The locations of chassis mounted parts and major assemblies are shown in Figure 8-18. The location of individual components mounted on printed circuit boards or other assemblies are shown on the appropriate schematic page or on the page opposite it. The part reference designator is the assembly designation plus the part designation. (Example: A10R1 is R1 on the A10 assembly.) For specific component description and ordering information refer to the parts list in Section VI.















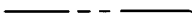
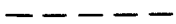



8-18. FACTORY SELECTED COMPONENTS. Some component values are selected at the time of final checkout at the factory. Usually these values are not extremely critical; they are selected to provide optimum compatibility with associated components. These components, which are identified on the schematics with an asterisk, are listed in Table 8-1. The recommended procedure for replacing a factory-selected component is as follows:

- a. Try the original value, then perform the test specified in Section V of this manual for the circuit being repaired.
- b. If the specified test cannot be satisfactorily performed, try the typical value shown in the parts list and repeat the test.

Table 8-1. Factory Selected Components

Designation	Location	Purpose	Range of Values
R12	Front Panel	To center range of CTR ADJ	3.16 — 16K to 4.75K
A6R22	HF Decade	Adjust gain	24.6 to 38.3
A6R24	HF Decade	Adjust dc level at input to decade counter	34.4 to 42.2
A8R6	Video Amp	Unleveled output adjust	10, 23.7, 38.3, 56.2, 75, 100, 121, 167, 196, 215, 261, 287, 348, 383, 422, 511 (Resistor values given resolve gain in 1 dB steps.)
A13R20	First Conv.	Center range of TRACKING ADJUST potentiometer	348 to 1.47K
A14R33	Sense Amp	20 volt adjust	110 to 1.2K
A14R38	Sense Amp	6 volt adjust	1.47K to 2.61K
A14R43	Sense Amp	-12 volt adjust	1.33K to 1.96K
A15R11	Rectifier	+175 volt adjust	619 to 1.78K

Table 8-2. Schematic Diagram Notes

SCHEMATIC DIAGRAM NOTES	
Refer to MIL Std 15B for Symbols Not Shown	
Resistance is in ohms and capacitance is in picofarads unless otherwise noted. P/O = part of. *Asterisk denotes a factory-selected value. Value shown is typical. Capacitors may be omitted or resistors jumpered.	
	Screwdriver adjustment.
	Panel control.
	Encloses front panel designations.
	Encloses rear panel designation.
	Circuit assembly borderline.
	Other assembly borderline.
	Heavy line with arrows indicates path and direction of main signal.
	Heavy dashed line with arrows indicates path and direction of main feedback.
	Wiper moves toward CW with clockwise rotation of control as viewed from shaft or knob.
	Numbers in stars on circuit assemblies show locations of test points.
	Encloses wire color code. Code used (MIL-STD-681) is the same as the resistor color code. First number identifies the base color, second number the wider stripe, and the third number identifies the narrower stripe. E.g., (947) denotes white base, yellow wide stripe, violet narrow stripe.
	Voltage regulator (breakdown diode).
	
	Denotes Field Effect transistor (FET) with N-type base.
	Denotes FET with P-type base.
	Denotes Capacitive diode (Varicap, varactor).
	Denotes Silicon Controlled Rectifier.
	P-Type Metal Oxide Substrate FET (MOSFET)
	N-Type Metal Oxide Substrate FET (MOSFET)

c. If the test results are still not satisfactory, substitute various values within the tolerances specified in Table 8-1 until the desired result is obtained.

8-19. DIAGRAM NOTES. Table 8-2, Schematic Diagram Notes, provides information relative to symbols and values shown on schematic diagrams.

8-20. GENERAL SERVICE HINTS.

8-21. The etched circuit boards used in Hewlett-Packard equipment are the plated-through type consisting of metallic conductors bonded to both sides of an insulating material. The metallic conductors are extended through the component holes by a plating process. Soldering can be performed on either side of the board with equally good results. Table 8-3 lists recommended tools and materials for use in repairing etched circuit boards. Following are recommendations and precautions pertinent to etched circuit repair work.

a. Avoid unnecessary component substitution; it can result in damage to the circuit board and/or adjacent components.

b. Do not use a high power soldering iron on etched circuit boards. Excessive heat may lift a conductor or damage the board.

c. Use a suction device (Table 8-3) or wooden toothpick to remove solder from component mounting holes.

CAUTION

Do not use a sharp metal object such as an awl or twist drill for this purpose. Sharp objects may damage the plated-through conductor.

d. After soldering, remove excess flux from the soldered areas and apply a protective coating to prevent contamination and corrosion.

8-22. COMPONENT REPLACEMENT. The following procedures are recommended when component replacement is necessary:

a. Remove defective component from board.

Table 8-3. Etched Circuit Soldering Equipment

Item	Use	Specification	Item Recommended
Soldering tool	Soldering Unsoldering	Wattage rating: 47-1/2 — 56-1/2 Tip Temp: 850 — 900°	Ungar #776 handle with *Ungar #4037 Heating Unit
Soldering* Tip	Soldering Unsoldering	*Shape: pointed	*Ungar #PL111
De-soldering aid	To remove molten solder from connection	Suction device	Soldapullt by Edsyn Co., Arleta, California
Resin (flux) solvent	Remove excess flux from soldered area before application of protective coating	Must not dissolve etched circuit base board material or conductor bonding agent	Freon Aceton Lacquer Thinner Isopropyl Alcohol (100% dry)
Solder	Component replacement Circuit board repair Wiring	Resin (flux) core, high tin content (60/40 tin/lead), 18 gauge (SWG) preferred	
Protective Coating	Contamination, corrosion protection	Good electrical insulation, corrosion-prevention properties	Krylon R ** #1302 Humiseal Protective Coating, Type 1B12 by Columbia Technical Corp., Woodside 77, New York

*For working on etched Boards: for general purpose work, use Ungar #1237 Heating Unit (37.5W, tip temp of 750 — 800) and Ungar #PL113 1/8 inch chisel tip
**Krylon, Inc., Norristow, Pennsylvania

b. If component was unsoldered, remove solder from mounting holes with a suction device (Table 8-3) or a wooden toothpick.

c. Shape leads of replacement component to match mounting hole spacing.

d. Insert component leads into mounting holes and position component as original was positioned. Do not force leads into mounting holes; sharp lead ends may damage the plated-through conductor.

Note

Although not recommended when both sides of the circuit board are accessible, axial lead components such as resistors and tubular capacitors, can be replaced without unsoldering. Clip leads near body of defective component, remove component and straighten leads left in board. Wrap leads of replacement component one turn around original leads. Solder wrapped connection and clip off excess lead.

8-23. BASIC SERVICE INFORMATION.

8-24. Since basic service information appears in the Spectrum Analyzer Service Manual, it will not be repeated here.

8-25. LOGIC CIRCUITS AND SYMBOLS.

8-26. The following paragraphs and illustrations provide basic information about logic circuits and symbols. While a complete treatment of the subject is not within the scope of this manual, it is believed that this material will help the technician experienced with analog devices, who has had little or no experience with digital circuits.

8-27. The circuits discussed are digital in nature; their outputs are always in one of two possible states, a "1" or "0". These two states are also referred to as being either high (H) or low (L). The high and low states are relative; low must be less positive (more negative) than high, both states may be positive or negative, or high may be positive and low negative. In positive logic the more positive (H) state is a logical "1" and the more negative (L) state is a logical "0". In negative logic the more negative (L) state is a logical "1" and the more positive (H) state is a logical "0".

8-28. Two of the basic "building blocks" of logic circuits are the AND and OR gates. The symbols and truth tables for basic AND and OR gates are shown in Figure 8-2.

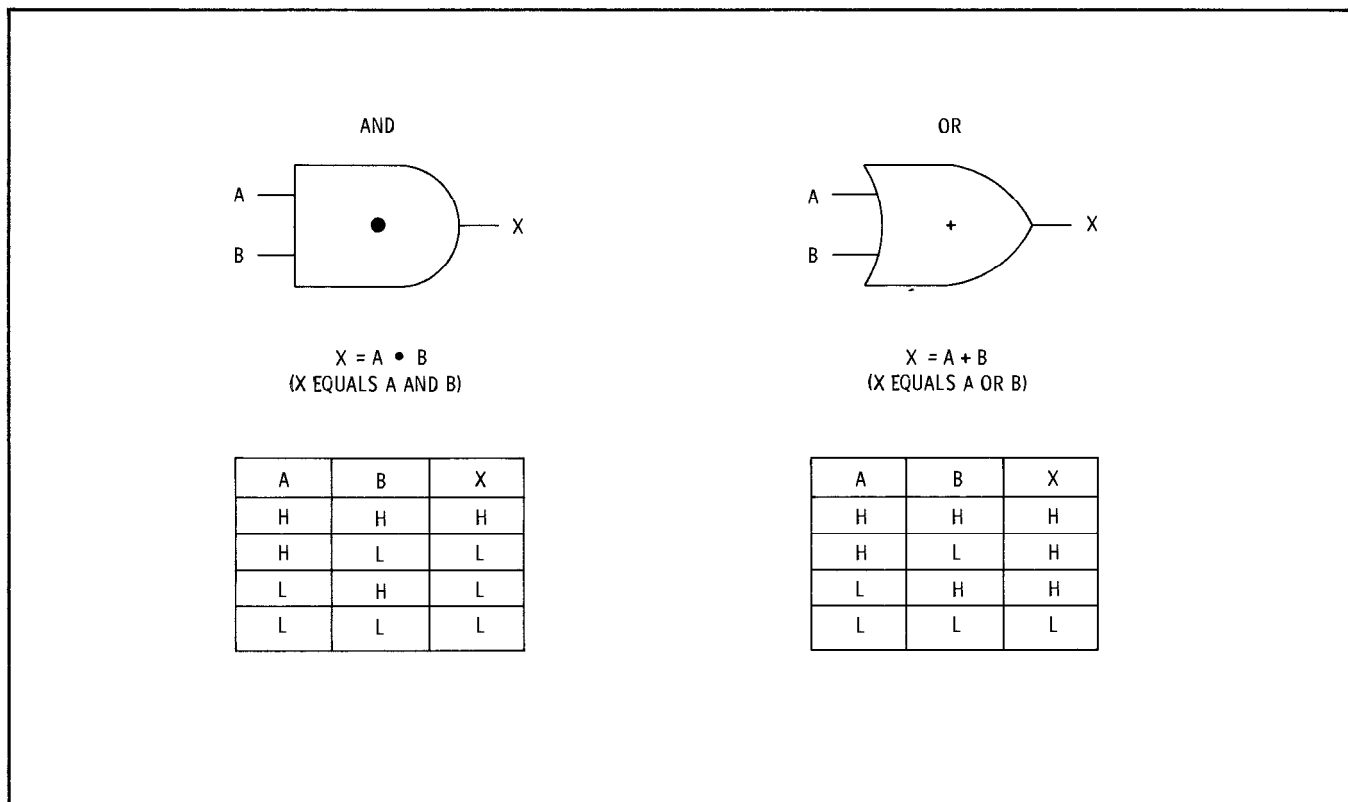

Figure 8-2. Basic AND and OR Gates

Table 8-4. Logic Symbology

1 indicates true signal 0 indicates false signal.		on symbol indicates logical inversion (not necessarily electrical) of the input or output signal(s). The logic indicated within the symbol remains the same. indicates direction of signal flow.																																	
Designation	Logic Symbol	Description	Truth Table																																
AND Gate (Positive True)		Both input signals (A and B) must be true simultaneously to produce a true output at C.	<table border="1"> <thead> <tr> <th>A</th> <th>B</th> <th>C</th> </tr> </thead> <tbody> <tr> <td>0</td> <td>0</td> <td>0</td> </tr> <tr> <td>0</td> <td>1</td> <td>0</td> </tr> <tr> <td>1</td> <td>0</td> <td>0</td> </tr> <tr> <td>1</td> <td>1</td> <td>1</td> </tr> </tbody> </table>	A	B	C	0	0	0	0	1	0	1	0	0	1	1	1																	
A	B	C																																	
0	0	0																																	
0	1	0																																	
1	0	0																																	
1	1	1																																	
OR Gate (Positive True)		If either input signal (A or B) or both is true, the output at C is true.	<table border="1"> <thead> <tr> <th>A</th> <th>B</th> <th>C</th> </tr> </thead> <tbody> <tr> <td>0</td> <td>0</td> <td>0</td> </tr> <tr> <td>0</td> <td>1</td> <td>1</td> </tr> <tr> <td>1</td> <td>0</td> <td>1</td> </tr> <tr> <td>1</td> <td>1</td> <td>1</td> </tr> </tbody> </table>	A	B	C	0	0	0	0	1	1	1	0	1	1	1	1																	
A	B	C																																	
0	0	0																																	
0	1	1																																	
1	0	1																																	
1	1	1																																	
Multiple Input Gate (Positive True)		Any combinations of inputs may be used with an AND or OR Gate to obtain a desired output. In the AND gate shown, input B is inverted and inputs A and C are without inversion. Inputs A and C must both be true and input B must be false simultaneously to produce a true output at D.	<table border="1"> <thead> <tr> <th>A</th> <th>B</th> <th>C</th> <th>D</th> </tr> </thead> <tbody> <tr> <td>0</td> <td>0</td> <td>0</td> <td>0</td> </tr> <tr> <td>0</td> <td>1</td> <td>0</td> <td>0</td> </tr> <tr> <td>0</td> <td>1</td> <td>0</td> <td>0</td> </tr> <tr> <td>0</td> <td>1</td> <td>1</td> <td>0</td> </tr> <tr> <td>1</td> <td>0</td> <td>0</td> <td>1</td> </tr> <tr> <td>1</td> <td>1</td> <td>1</td> <td>0</td> </tr> <tr> <td>1</td> <td>1</td> <td>1</td> <td>1</td> </tr> </tbody> </table>	A	B	C	D	0	0	0	0	0	1	0	0	0	1	0	0	0	1	1	0	1	0	0	1	1	1	1	0	1	1	1	1
A	B	C	D																																
0	0	0	0																																
0	1	0	0																																
0	1	0	0																																
0	1	1	0																																
1	0	0	1																																
1	1	1	0																																
1	1	1	1																																
Time Delay		Input signal delayed by the time indicated. True input at A produces a true output at B after a 15 ms delay.	RC and RF Coupling																																

Table 8-4. Logic Symbology (Cont.)

Designation	Logic Symbol	Description	Truth Table	Typical Circuit
<p>Trigger</p>		<p>The binary is a flip-flop which changes state with every true input pulse at A. Since A is applied to the bases of both transistors, it is shown centered in the symbol. The negative pulse produces the same effect as a positive pulse applied to the opposite base. To preserve the positive logic, the reset pulse is shown inverted and applied to the opposite side. A reset pulse sets B true.</p>		
<p>One-Shot</p>		<p>True input at A sets the one-shot to unstable state (active) and produces a true output at B. In the symbol shown, the A input must be false (positive) with respect to negative true logic of the one-shot. During the stable state, the B output is true. A true input at C (direct set) holds the one-shot in the unstable state.</p>		

Table 8-4. Logic Symbology (Cont.)

Designation	Logic Symbol	Description	Truth Table	Typical Circuit
Amplifier		<p>True input at A produces amplified true output at B. An amplifier will function with either positive true or negative true signals.</p>		
Inverter Amplifier		<p>True input at A produces false output at B and false input at A produces a true output at B (inverts the input logic level).</p>		
Flip-Flop		<p>Outputs \bar{D} and D are always in opposite states — if D is true, \bar{D} is false. A true input will cause the output directly across to go true — true input at A sets output D true. With no input, the flip-flop remains in the state set by the last input signal. A true input at B will cause the flip-flop to reverse state. A true input at the direct reset input E holds the flip-flop in the \bar{D} true state.</p>		

8-29. BASIC AND GATE (Positive logic). The basic AND gate is a circuit which produces an output "1" when, and only when, a "1" is applied to all inputs. As shown in Figure 8-2, terminal X will be high only when terminals A and B are both high. The dot (•) shown in the AND gate is the logic term for AND. The term for a simple two input AND gate is $X = A \bullet B$ (X equals A and B). AND gates may be designed to have as many inputs as required to fill a specific requirement.

8-30. BASIC OR GATE (Positive logic). The basic OR gate is a circuit which produces a "1" output when any one, or all of the inputs are in a "1" state. As shown in Figure 8-2, terminal X will be high when either terminal A or terminal B, or both are high. The + shown in the OR gate symbol is the logic term for OR. The term for a simple two input OR gate is $X = A + B$ (X equals A or B). OR gates may be designed to have as many inputs as required for specific needs.

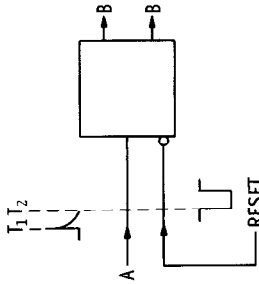
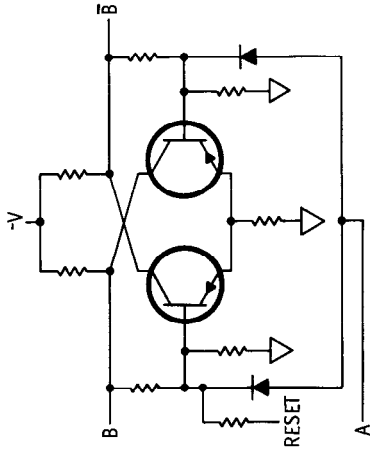
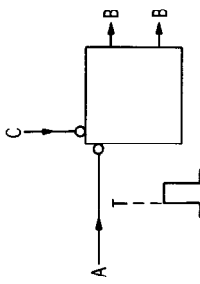
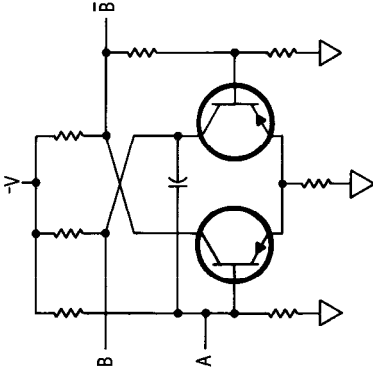
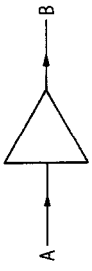
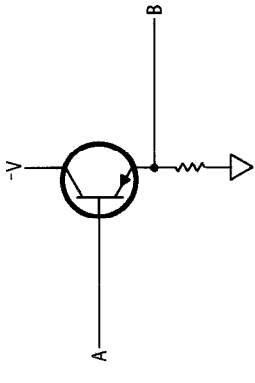
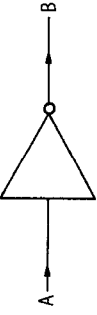
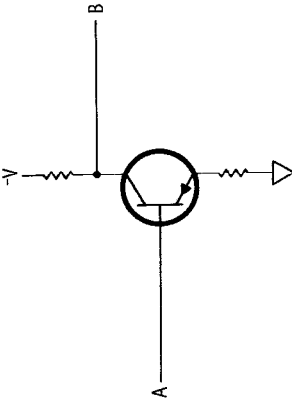
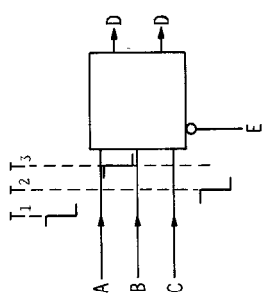
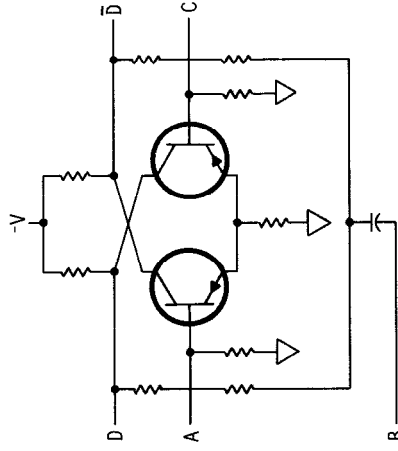
8-31. The symbols for AND and OR gates differ in that AND gate symbols have a flat input side and a rounded output side while OR gate symbols have a concave input side and a pointed output side.

8-32. TRUTH TABLES. Truth tables provide a means of presenting the output state of logic devices for any set of inputs in tabular form. Truth tables contain one column for each of the inputs and a column for the output. In basic truth tables the column notations are usually H or L (for high and low) or, for binary notation, "1" or "0". More complex truth tables use other terms which will be explained where these tables appear in the text.

8-33. LOGIC INVERSION. Adding inversion to AND and OR gates changes their characteristics. Inversion is usually accomplished by adding an inverter stage (common emitter) in front of an input or after an output. A circle added to the input or output leads indicates the portion of the circuit in which the inversion takes place. The simplest of these devices are AND and OR gates in which the output is inverted. These gates are called NAND (for Not AND) and NOR (for Not OR). Basic NAND and NOR gates are shown in Figure 8-3. When all inputs and outputs of an AND gate are inverted, it functions as an OR gate. When all inputs and outputs of an OR gate are inverted, it functions as an AND gate. Figure 8-4 provides information relative to various gate inversion functions.

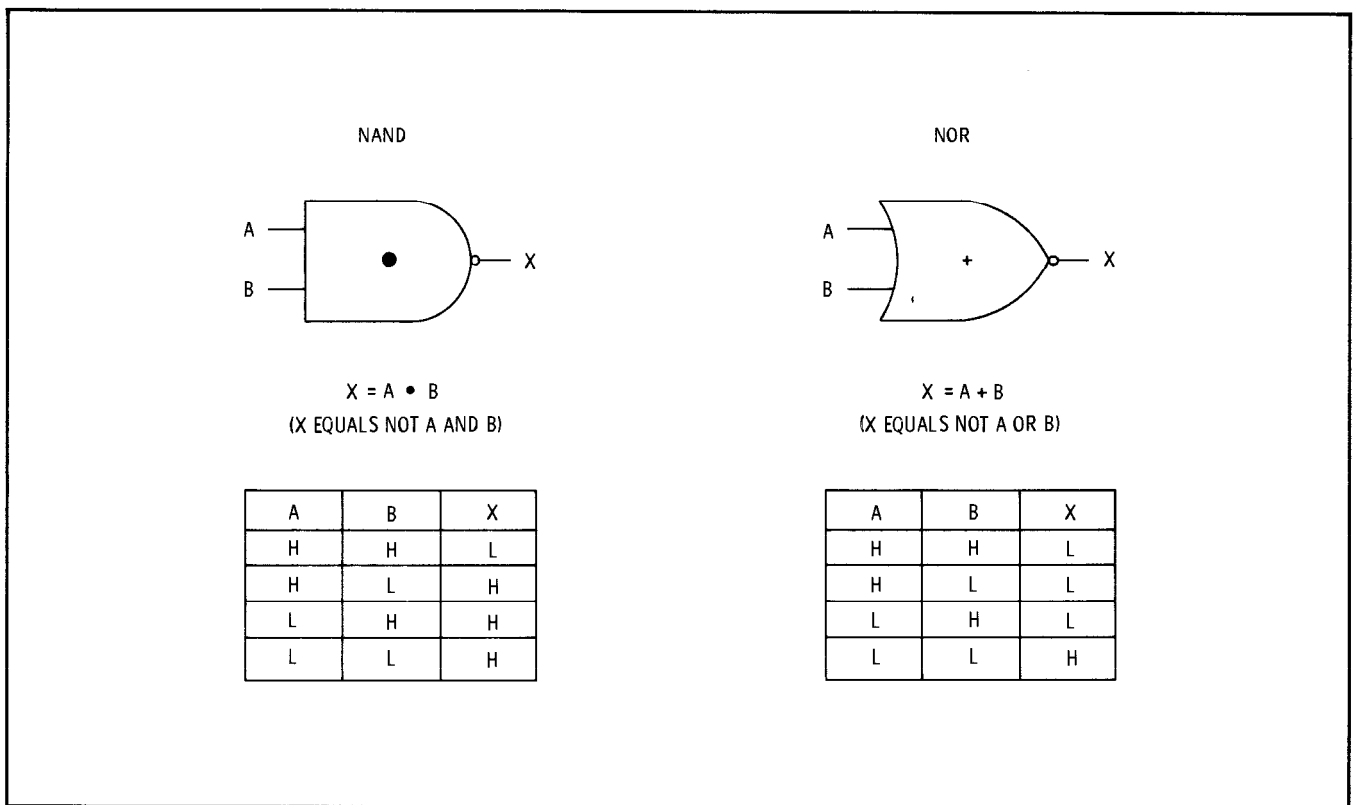

Figure 8-3. Basic NAND and NOR Gates

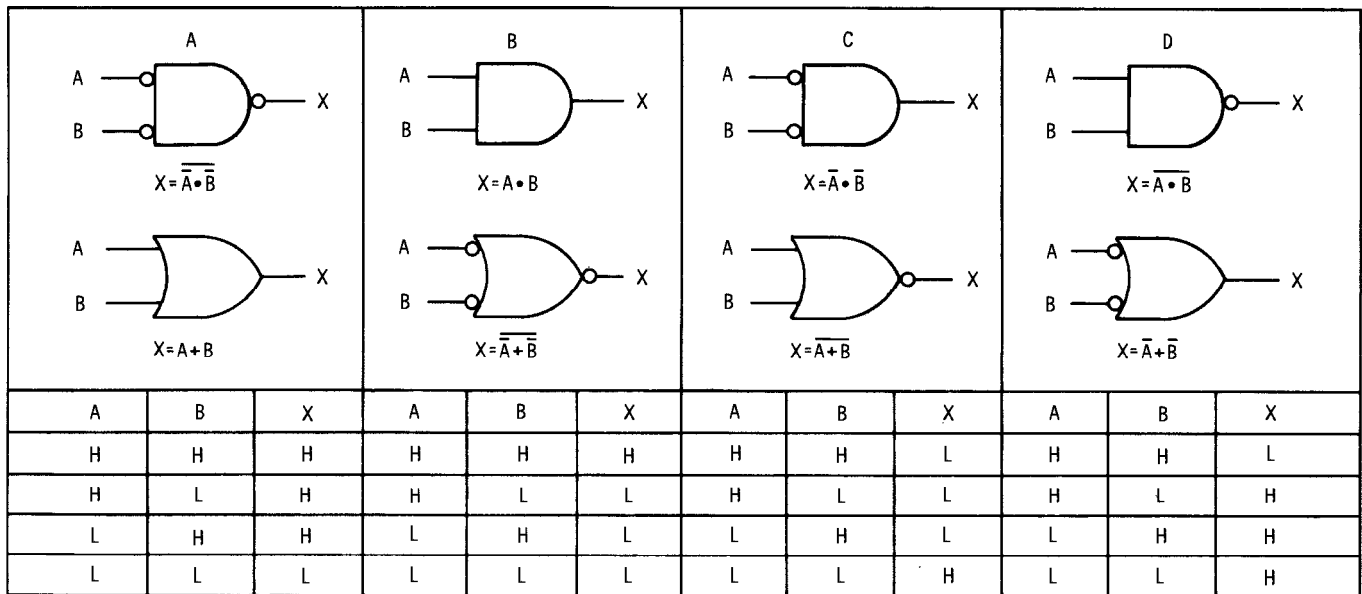

Figure 8-4. Logic Comparison Diagrams

8-34. When inversion is used the designation at the inverted terminal is frequently termed \bar{A} (not A), \bar{B} (not B), \bar{X} (not X), etc. Table 8-4 shows basic logic, circuits and associated symbology.

8-35. **BINARY CIRCUITS.** Many types of flip-flops are used in binary circuits. Each half of a flip-flop is in one of two states at any given time. The outputs are complementary; when one stage is on, the other is off. The outputs are termed 1 and 0, high and low, or true and false, by the same rules that apply to AND and OR gates. The outputs may be identified in many different ways. This text identifies these outputs as Q and \bar{Q} for the sake of uniformity. Basic flip-flops which are particularly adaptable to binary circuits and combinations of flip-flops are discussed in the following paragraphs.

8-36. **BASIC NOR GATE FLIP-FLOP.** Figure 8-5 illustrates a flip-flop constructed with two NOR gates. Operation of the circuit is described below. Assume that initially Q is high and \bar{Q} is low, and A and B are both low. When a high is applied to input A, Q goes low and since there are now two lows applied to NOR gate 2, \bar{Q} will go high. The \bar{Q} high is applied back to NOR gate 1, but since Q is already low, no change in state results. When a high is applied to input B the flip-flop again reverses state. Since the flip-flop will remain in the last state to which it is set, it "remembers" which signal was last received, and can be used as a memory circuit.

8-37. **TRIGGERED FLIP-FLOP.** Figure 8-6 illustrates a triggered flip-flop which changes state each time a pulse of a given polarity is applied to the input. The output of a triggered flip-flop is a square wave at one half the frequency of the input triggers. In the circuit shown in Figure 8-6 the input may be negative going triggers or a square wave. If the input is a square wave it will be differentiated by C2 to produce both negative going and positive going pulses. Assume that initially Q is low (Q2 on) and \bar{Q} is high (Q1 off).

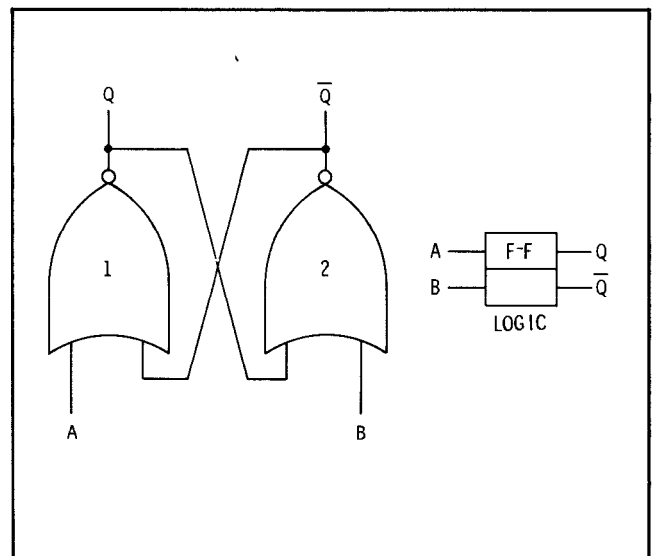

Figure 8-5. Basic NOR Gate Flip-Flop

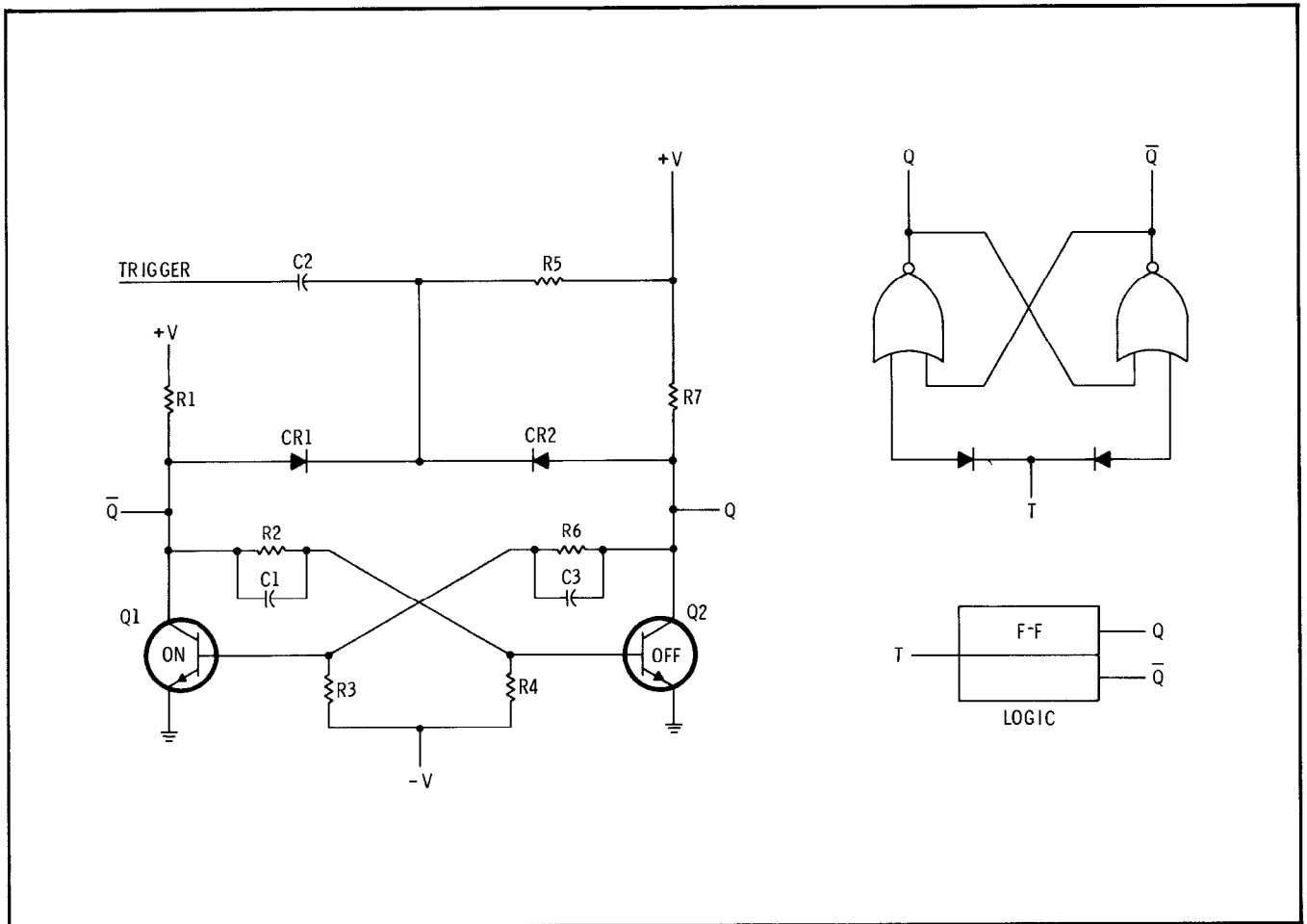

Figure 8-6. Triggered Flip-Flop

When a negative going trigger appears at the junction of CR1 and CR2 it has no effect on Q2 through CR2 because output Q is low. However, CR1 is forward biased by the high at \bar{Q} and the trigger is coupled to the collector of Q1. As the collector of Q1 is driven in a negative direction the trigger is also coupled through C1 to the base of Q2. As Q2 begins to cut off, the positive going collector voltage is coupled to the base of Q1 through C3 to drive Q1 into conduction. The process is regenerative; Q2 cuts off quickly and Q1 goes into saturation. The next negative going trigger reverses the procedure just described.

8-38. RESET-SET (RS) FLIP-FLOP. Figure 8-7 shows an RS flip-flop. The RS flip-flop has two inputs, S for Set and R for Reset (sometimes labeled S for set and C for clear). Assume that initially Q is high (Q2 off) and \bar{Q} is low (Q1 on). In this state the flip-flop is set and a positive pulse at the set input will not affect the circuit. When a positive pulse is applied to the reset input it is coupled through C4 and CR2 to the base of Q2. Q2 begins to conduct and the negative going collector voltage is coupled through C3 to the

base of Q1 to cut off Q1. The process is regenerative; Q1 is quickly cut off and Q2 saturates. The flip-flop will remain in the reset state until a positive set pulse is applied through C2 and CR1 to the base of Q1. Note that operation of the RS flip-flop is the same as operation of the basic NOR gate flip-flop described in paragraph 8-36.

8-39. RST FLIP-FLOP. Figure 8-8 illustrates a RST flip-flop which is a combination of reset-set and triggered flip-flops. In the circuit shown, negative trigger pulses will make the flip-flop change states. Positive pulses are required for the set and reset inputs. A positive set input will cause \bar{Q} to go high and a positive reset pulse will cause Q to go high.

8-40. CLOCKED JK FLIP-FLOP. A clocked JK flip-flop is triggered by an input clock pulse when certain conditions prevail at the J and K inputs. Figure 8-9 illustrates the logic symbol for a JK flip-flop derived from a RS flip-flop and two three-input AND gates. Figure 8-10 shows a typical JK flip-flop integrated circuit schematic diagram. JK flip-flops have three inputs (J, K and

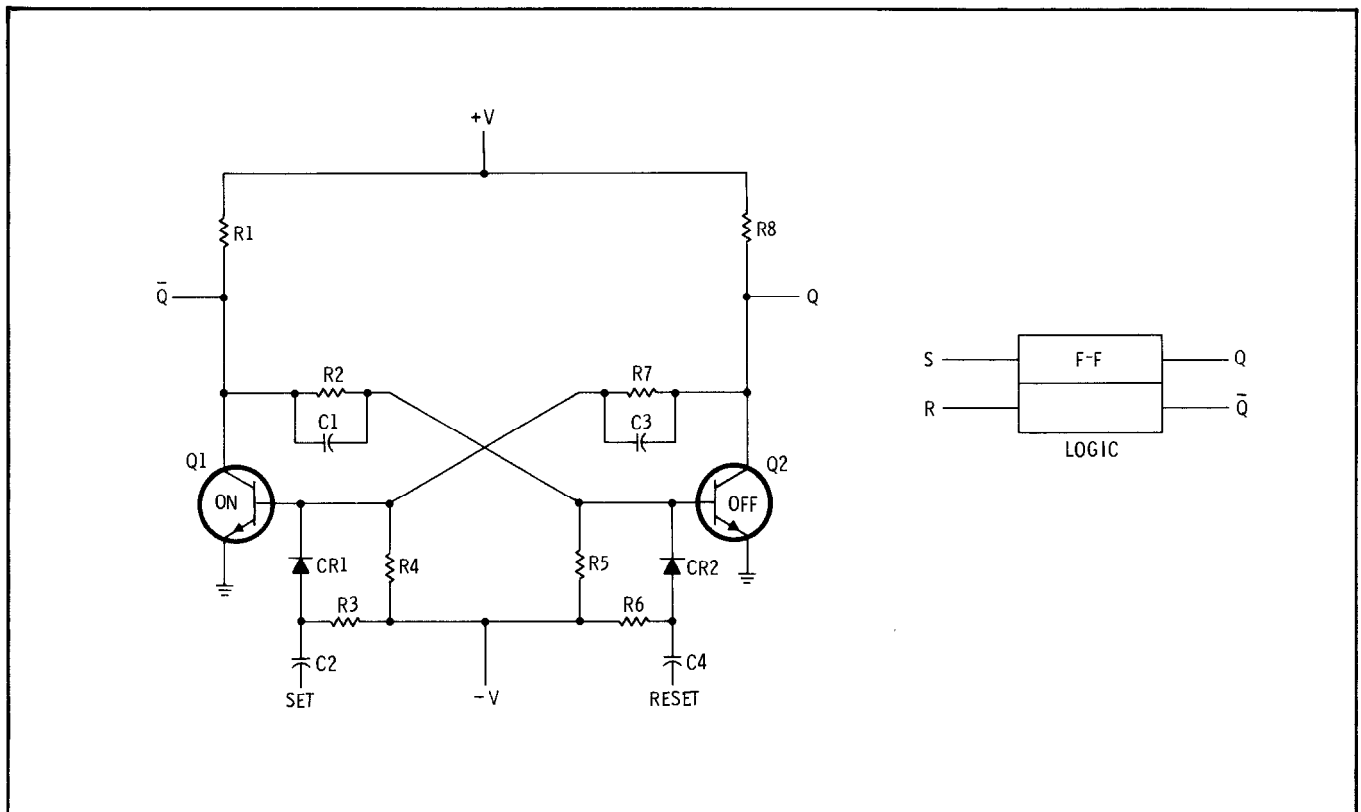

Figure 8-7. RS Flip-Flop

Clock) and complementary outputs. JK flip-flops used as decade counters also have clear or reset inputs, preset and in some cases, a blanking input. When the J and K inputs are both high the flip-flop changes state every time a clock pulse appears; operation is the same as a triggered flip-flop. When the J input is high and the K input is low Q will go high; operation is the same as the reset in RS flip-flops. When the J input is low and the K input is high Q will go high; operation is the same as the reset in RS flip-flops. When the J and K inputs are both low clock pulses do not affect the circuit. Frequently JK flip-flops are shown schematically with no connection shown to the J and K inputs; when this occurs, both J and K are actually held high and the circuit functions as a triggered flip-flop.

8-41. BINARY LOGIC. The following paragraphs will explain the basic binary logic required to understand the operation of the dividers and decade counters used in a frequency counter.

8-42. In frequency counters the decimal numbers 0 through 9 are displayed on each readout device. For this reason, only binary numbers 0000 through 1001, which correspond to decimal numbers 0 through 9 will be discussed in this text. The only exception to this is the discussion of Figure 8-11 which follows.

8-43. Figure 8-11 illustrates four triggered flip-flops in series, with the Q outputs of the first three driving the trigger inputs of the next flip-flop. Since each flip-flop is triggered only by negative going excursions of the input signal, each provides one cycle of output signal for two cycles on input signal. The flip-flops, then, are weighted in ascending powers of two. The first flip-flop has a weighted value of 2^0 (1), the second has a weighted value of 2^1 (2), the third has a weighted value of 2^2 ($2 \times 2 = 4$) and the fourth has a weighted value of 2^3 ($2 \times 2 \times 2 = 8$).

8-44. Assume that initially the flip-flops in Figure 8-11 were all set to 0 (Q low). When seven input cycles have been received the flip-flops have operated as follows; the first has been turned on (Q high) by inputs 1, 3, 5 and 7, and turned off (Q low) by inputs 2, 4 and 6. The second flip-flop has been turned on by the first and third outputs of the first flip-flop (coincident with initial inputs 2 and 6) and turned off by the second output of the first flip-flop (coincident with initial input 4). The third flip-flop has been turned on by the first negative going output of the second flip-flop (coincident with initial input 4). The fourth flip-flop has not been triggered because there has been no negative going output from flip-flop three. The first three flip-flops are now in the 1 state (Q high) and the binary state

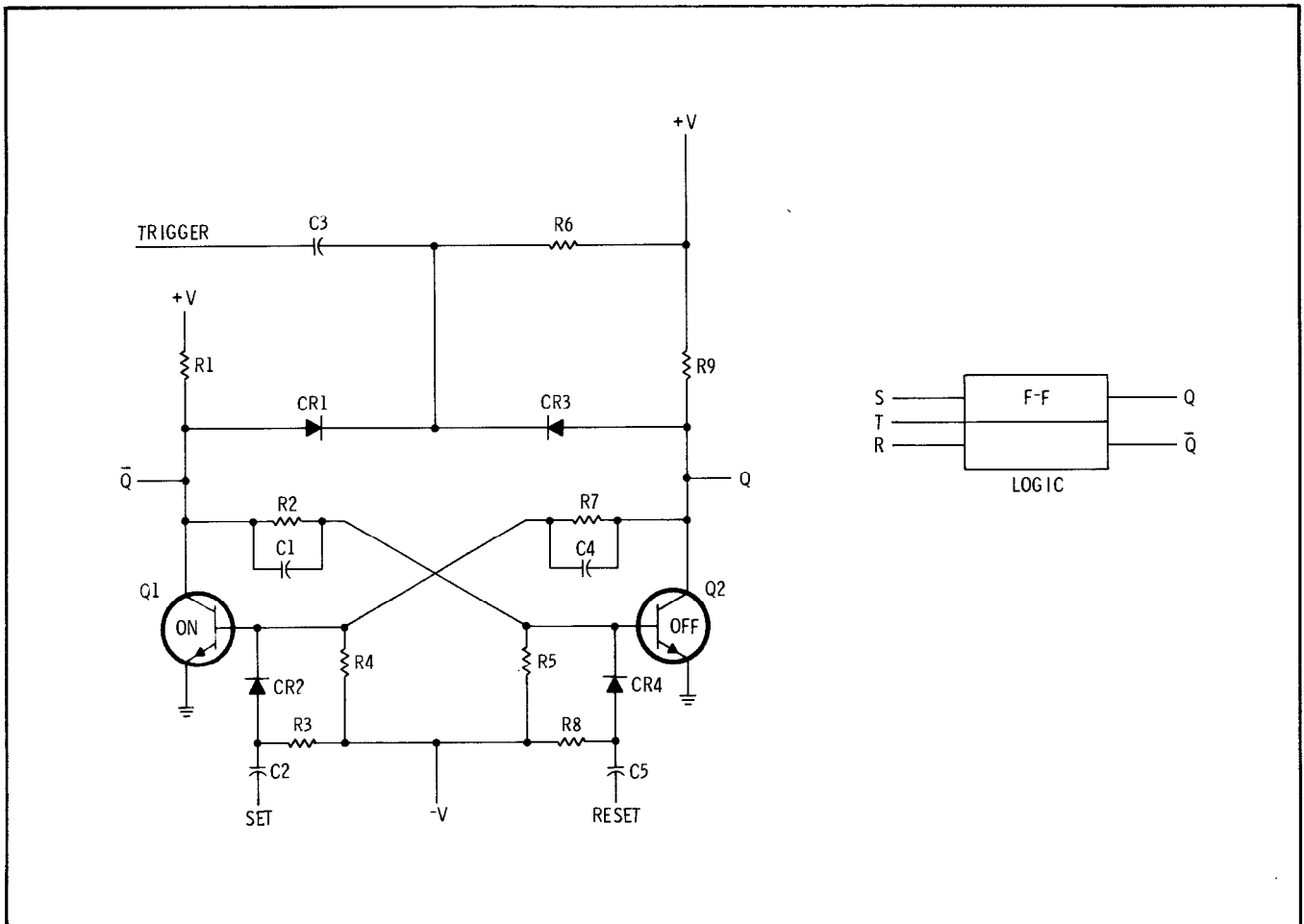

Figure 8-8. RST Flip-Flop

is 1110. Their decimal weighted value then is $2^0 + 2^1 + 2^2 = 1 + 2 + 4 = 7$. The next negative input to the chain will cause the first three flip-flops to go off and the fourth to go on. The binary state then is 0001; the decimal weighted value is $0 + 0 + 0 + 2^3 = 0 + 0 + 0 + 8 = 8$.

8-45. As the timing diagram in Figure 8-11 indicates, four flip-flops in this configuration are capable of counting up to 16. Since only the decimal digits 0 through 9 are used in counter circuits, a means must be provided to limit the count to ten. A means must also be provided to reset the flip-flops to zero before beginning a new count. The means by which these facilities are provided are discussed in later paragraphs.

8-46. Since binary numbers, like decimal numbers, are written in ascending order from right to left, the weighted values of the flip-flops are easier to understand in 8, 4, 2, 1 order. Table 8-6 lists the true binary numbers for 8, 4, 2, 1 binary weights and their decimal equivalents.

8-47. A SIMPLE 8421 BCD CODE DECADE COUNTER. Figure 8-12 illustrates a simplified decade counter using triggered RS flip-flops. This circuit operates like the circuit shown in Figure 8-11 up through decimal count 9 (binary 1001).

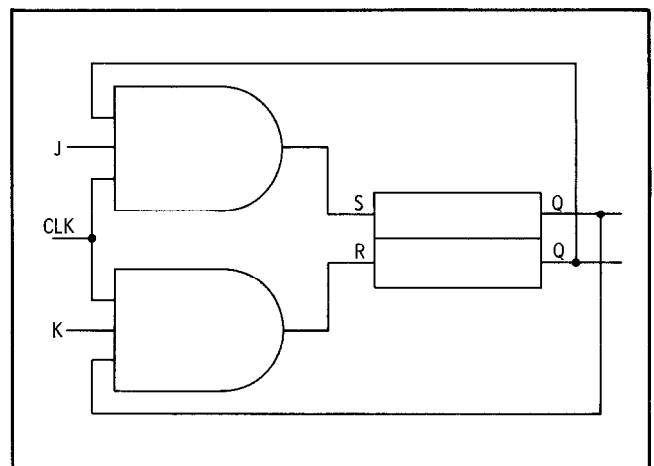
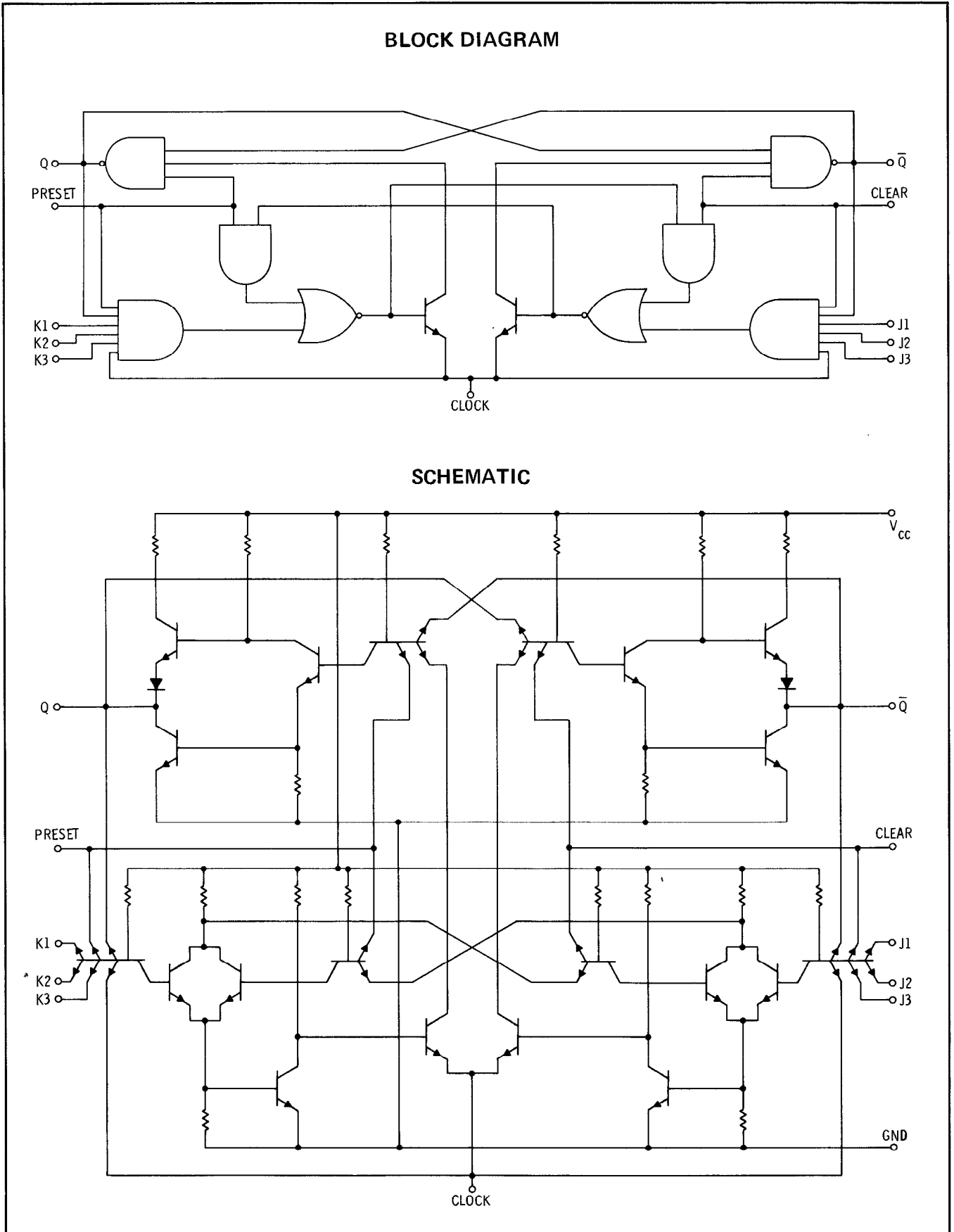

Figure 8-9. Clocked JK Flip-Flop



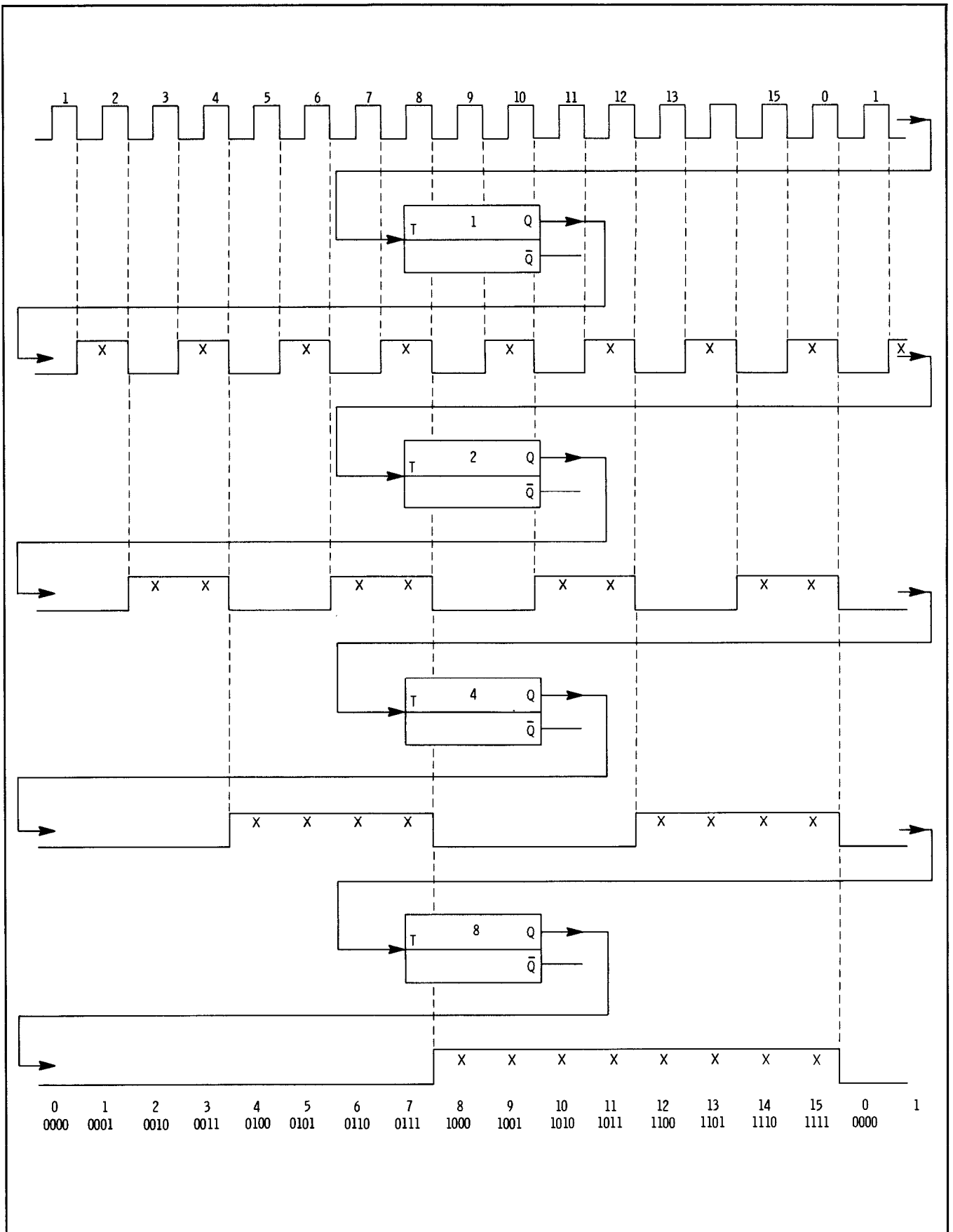

Figure 8-11. 16 Counter Binary Counter Chain

Table 8-5. JK Flip-Flop Truth Table

J	K	Before Trigger		After Trigger	
		Q	\bar{Q}	Q	\bar{Q}
0	0	1	0	1	0
0	1	1	0	0	1
1	0	0	1	1	0
1	1	0	1	1	0

Table 8-6. 15 Count Binary Truth Table

Binary				Decimal
$8 = 2^3$	$4 = 2^2$	$2 = 2^1$	$1 = 2^0$	
0	0	0	1	1
0	0	1	0	2
0	0	1	1	3
0	1	0	0	4
0	1	0	1	5
0	1	1	0	6
0	1	1	1	7
1	0	0	0	8
1	0	0	1	9
1	0	1	0	10
1	0	1	1	11
1	1	0	0	12
1	1	0	1	13
1	1	1	0	14
1	1	1	1	15
0	0	0	0	0

When the tenth pulse is received at the input flip-flop point A goes low, flip-flop point B goes high and the flip-flops are temporarily in the 1010 state. Almost immediately the output from B causes D to reset and the output from D then causes B to reset. The end result is that all flip-flops are reset to 0 by the tenth pulse and are ready to begin the next count. This circuit is useful as a divide by ten decade. To be used as a frequency counter a reset must be provided to reset all flip-flops to zero when the count ends at a number other than ten.

8-48. BLANKING DECADE COUNTER. Figure 8-13 illustrates a blanking decade counter. The circuit will divide by ten and provide BCD (binary coded decimal) outputs for decimal numbers 0 through 9. In addition, the A, B, C and D outputs may be set to 1111 (15) to cause the numerical readout device to be blanked.

8-49. The output of the blanking control NAND gate is normally high. When the JK flip-flops are reset their \bar{Q} outputs go high. After reset and before the frequency count begins the outputs of the A, D, B and C NAND gates are normally low because both inputs are high. Now if the blanking control input goes high and \bar{Q} of the first flip-flop is high, the blanking control NAND gate output goes low and the outputs of the A, D, B and C NAND gates go high. In actual use, inverters follow the A, D, B and C NAND gates to provide a negative logic BCD output of 1111 (decimal 15) to the decoders which have no gate to accept 1111, so none of the elements in the numerical readout devices are energized.

8-50. BUFFER-STORE. In frequency counters it is necessary to transfer the information stored in the decade counters to display decoders prior to starting the next count. Isolation must also be

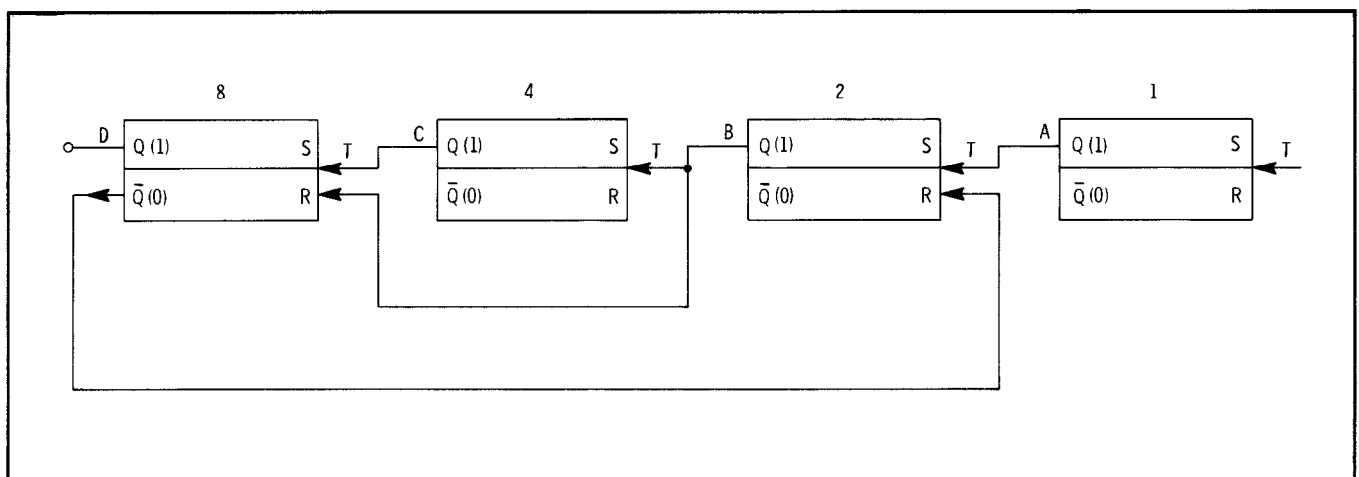

Figure 8-12. 8421 BCD Decade Counter

provided to prevent the display from being affected by a count while it is in progress. Figure 8-14 shows a typical buffer-store circuit.

8-51. The terminals labeled \bar{A} , \bar{B} , \bar{C} and \bar{D} at the bottom of Figure 8-14 are connected to the outputs of the decade counters. Operation of the buffer-store is described below. Normally the input labeled TRANSFER is high, the inverter output is low and all of the AND gates between the BCD inputs and the RS flip-flops are disabled. When the transfer pulse appears one of the two AND gates between the inputs and the RS flip-flops goes high. Assume that when the transfer pulse appears the \bar{A} input is low. The output of the reset AND gate of the first RS flip-flop goes high, the input to the \bar{A} inverter goes high and the inverter output goes low. If the A, B, C and D outputs are to be used, the GATE input must be high in order for the output NAND gates to function. With the \bar{A} input low the input to the A NAND gate from the RS flip-flop will be low and the NAND gate output will be high. When the A input is high the set AND gate output is high, both inputs to the A NAND gate are high

and the A output is low. At the same time the input to the \bar{A} inverter is low, so \bar{A} is high. Operation of the B, C and D circuits is identical to the A circuit. Typically the \bar{A} , \bar{B} , \bar{C} and \bar{D} outputs are used to drive decoders and the A, B, C and D outputs are used to drive recorders, Digital to Analog converters, etc.

8-52. **DECODER-DRIVER.** Decoder-drivers provide a means to "translate" the BCD binary code to a decimal equivalent to drive numerical read-out devices. Figure 8-15 shows ten four-input AND gates connected as a decoder. Each AND gate will respond to one, and only one, of the binary equivalents of decimal numbers 0 through 9. Example: the number 1 gate will provide a high output only when A is low and B, C and D are high.

8-53. **INTEGRATED CIRCUITS.** Many circuits used in counters and other equipment are available as integrated circuits. The last three circuits discussed are all available as integrated circuits. Figure 8-16 shows some of the packages used for integrated circuits.

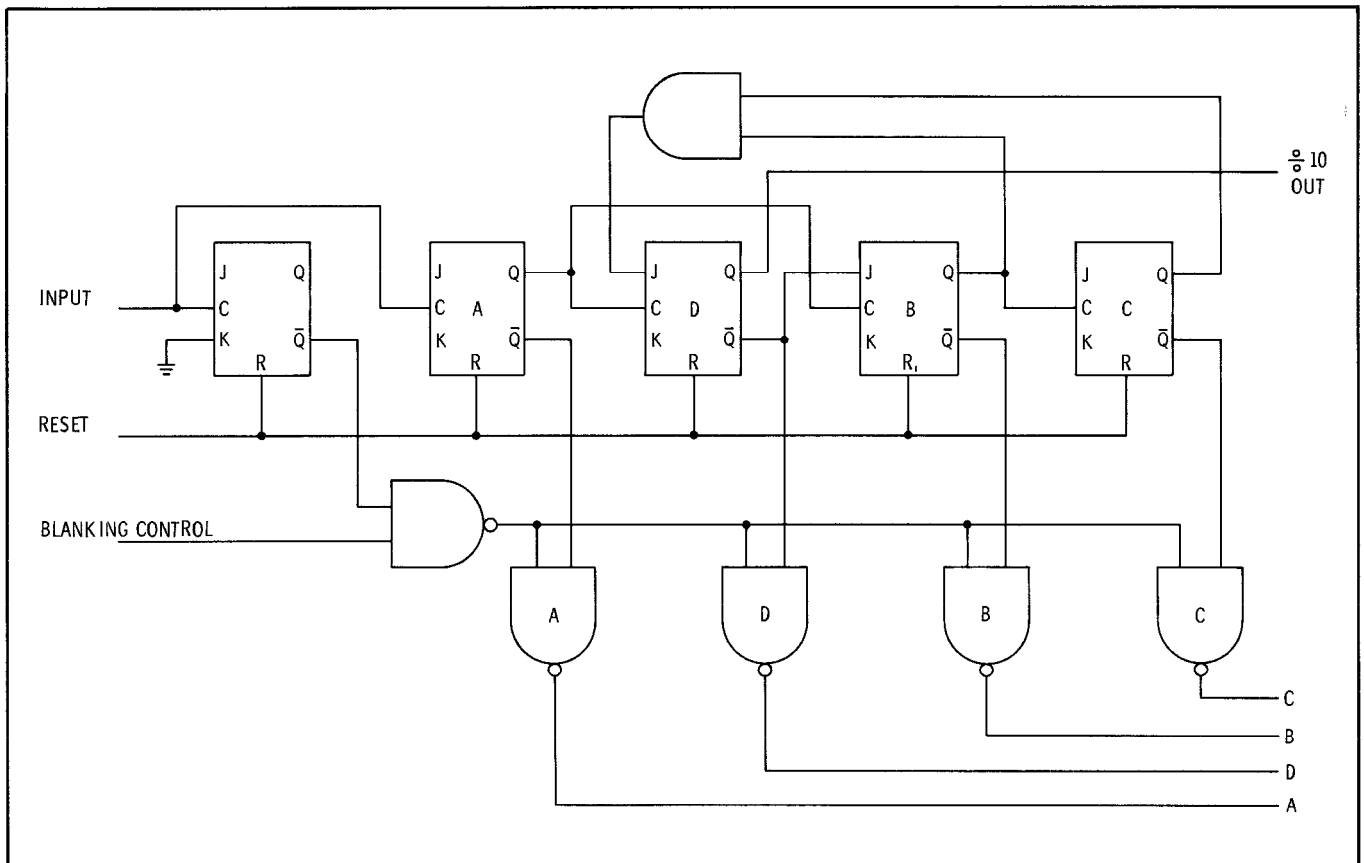

Figure 8-13. Blanking Decade Counter

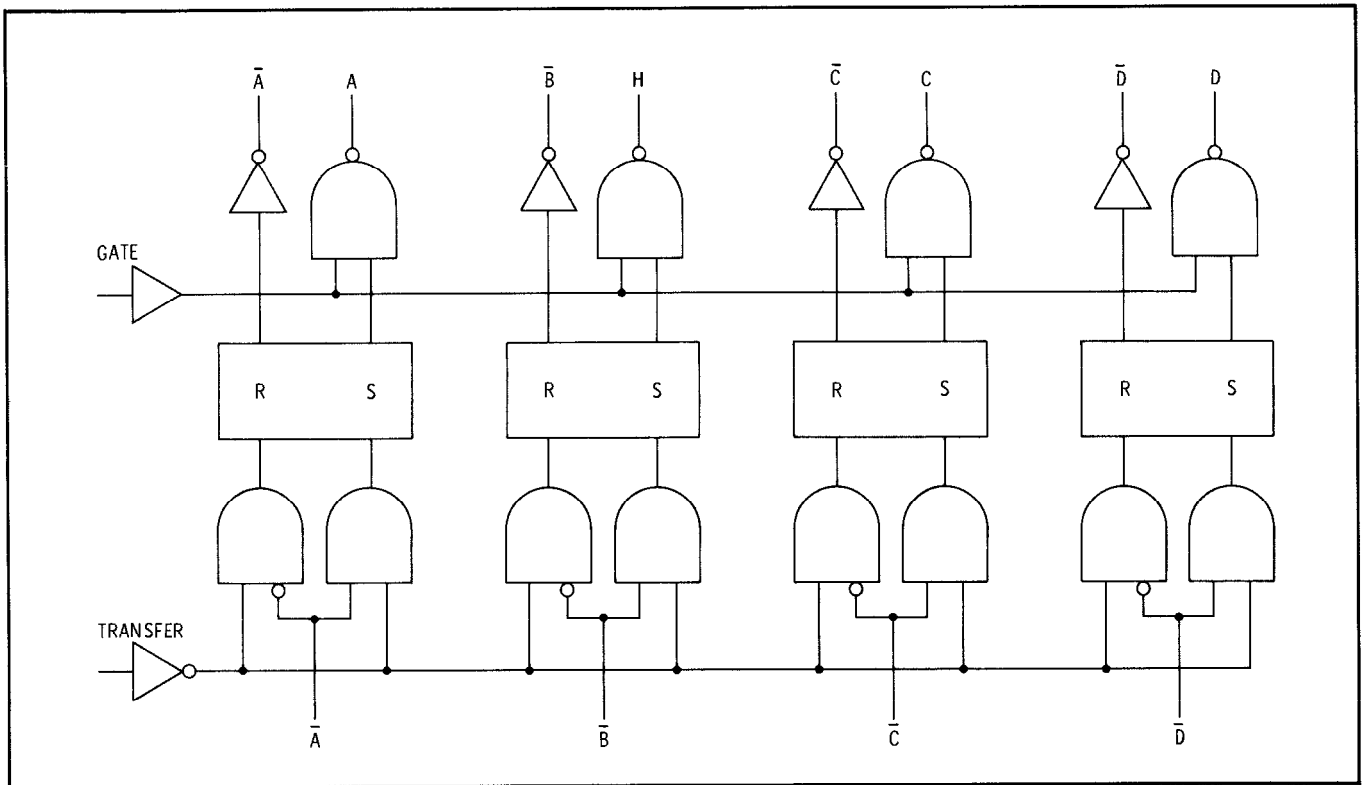

Figure 8-14. Buffer/Store

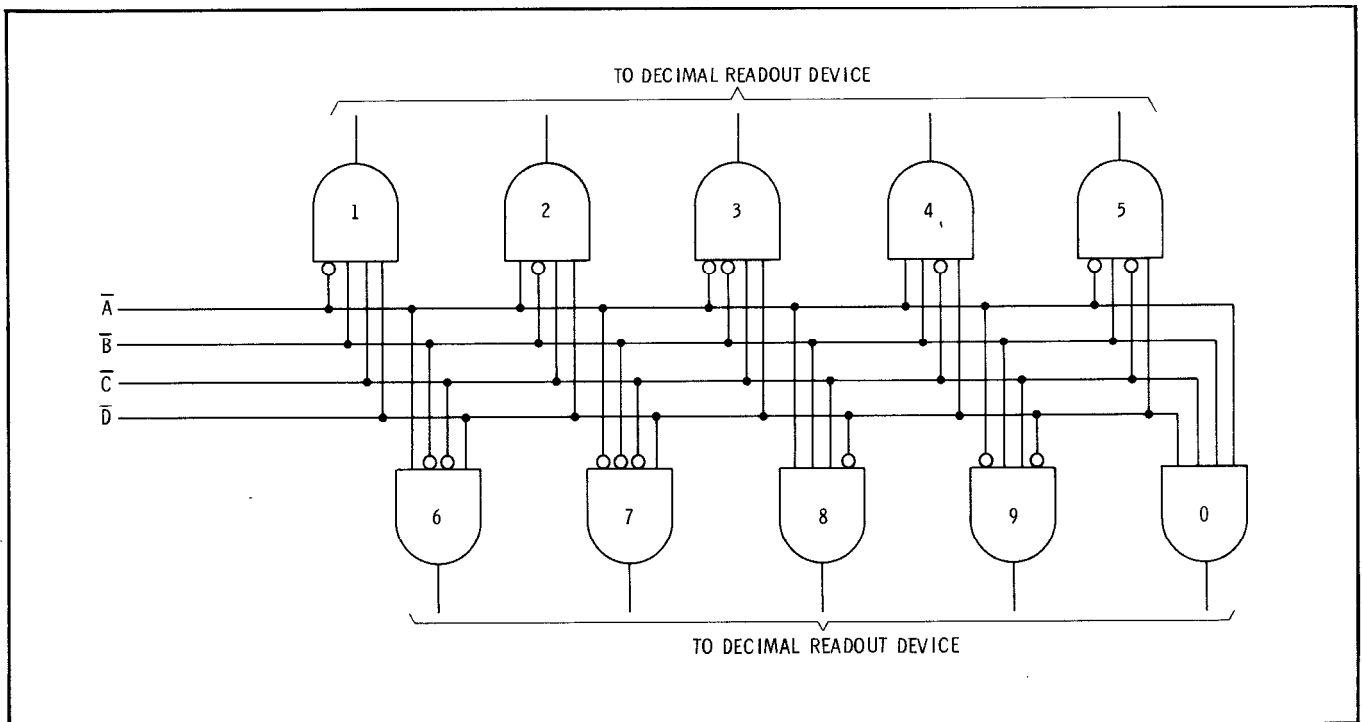

Figure 8-15. Decoder

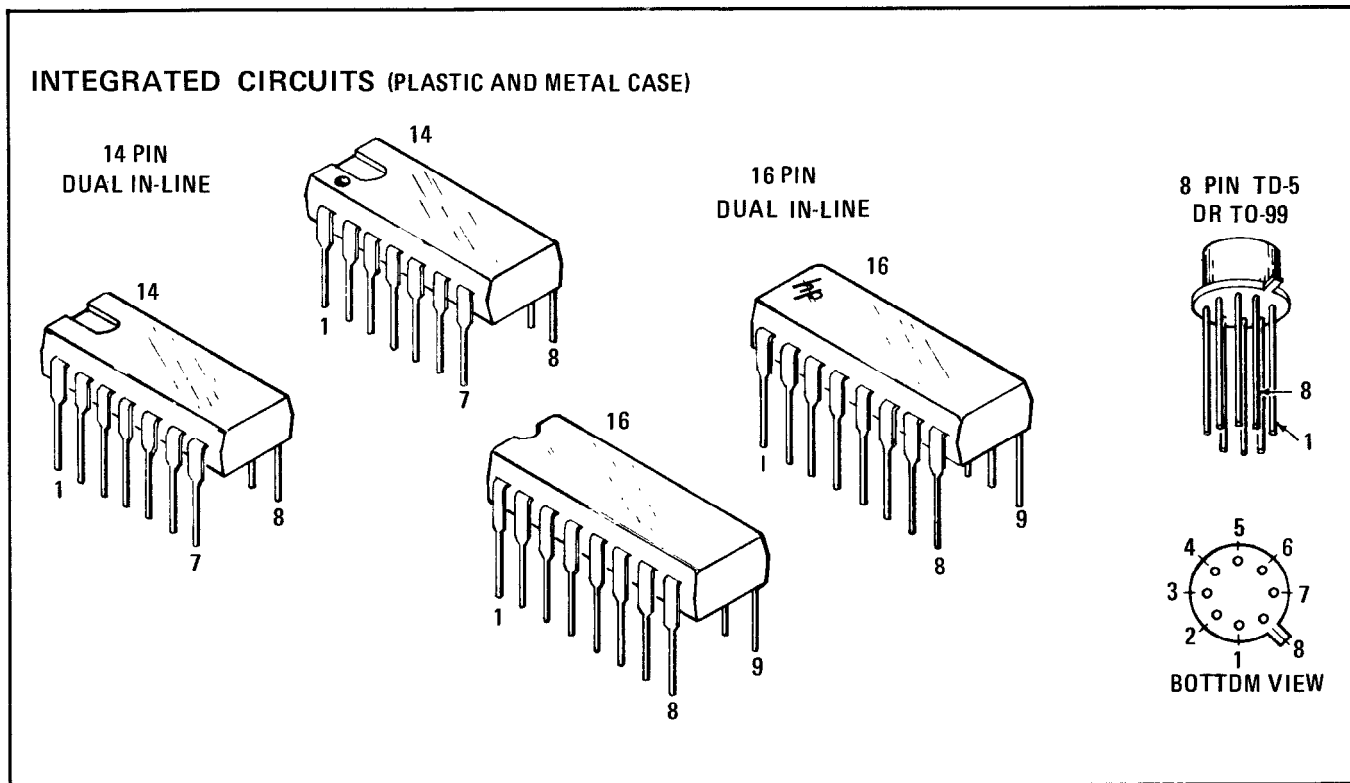

Figure 8-16. Integrated Circuit Packaging

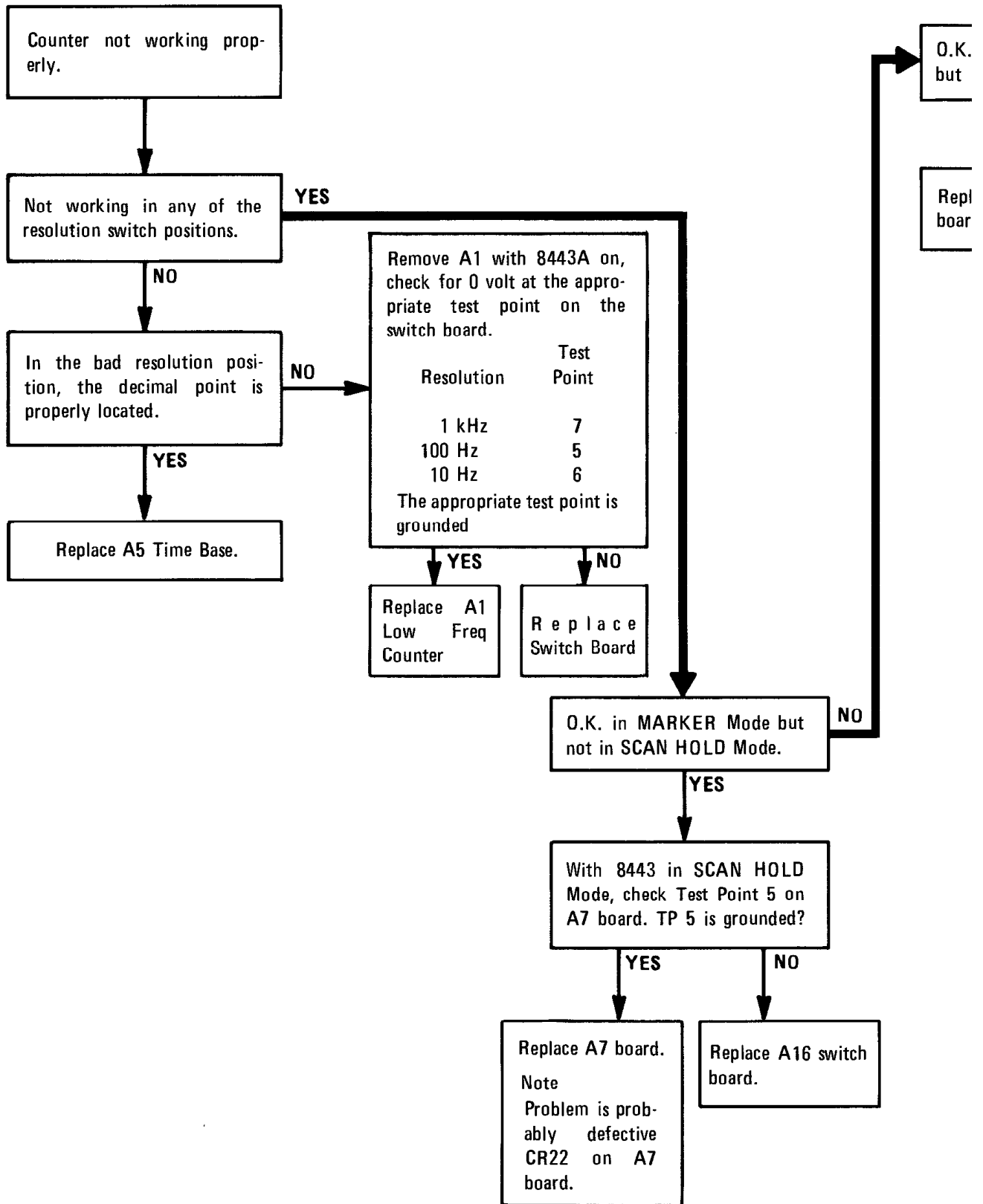
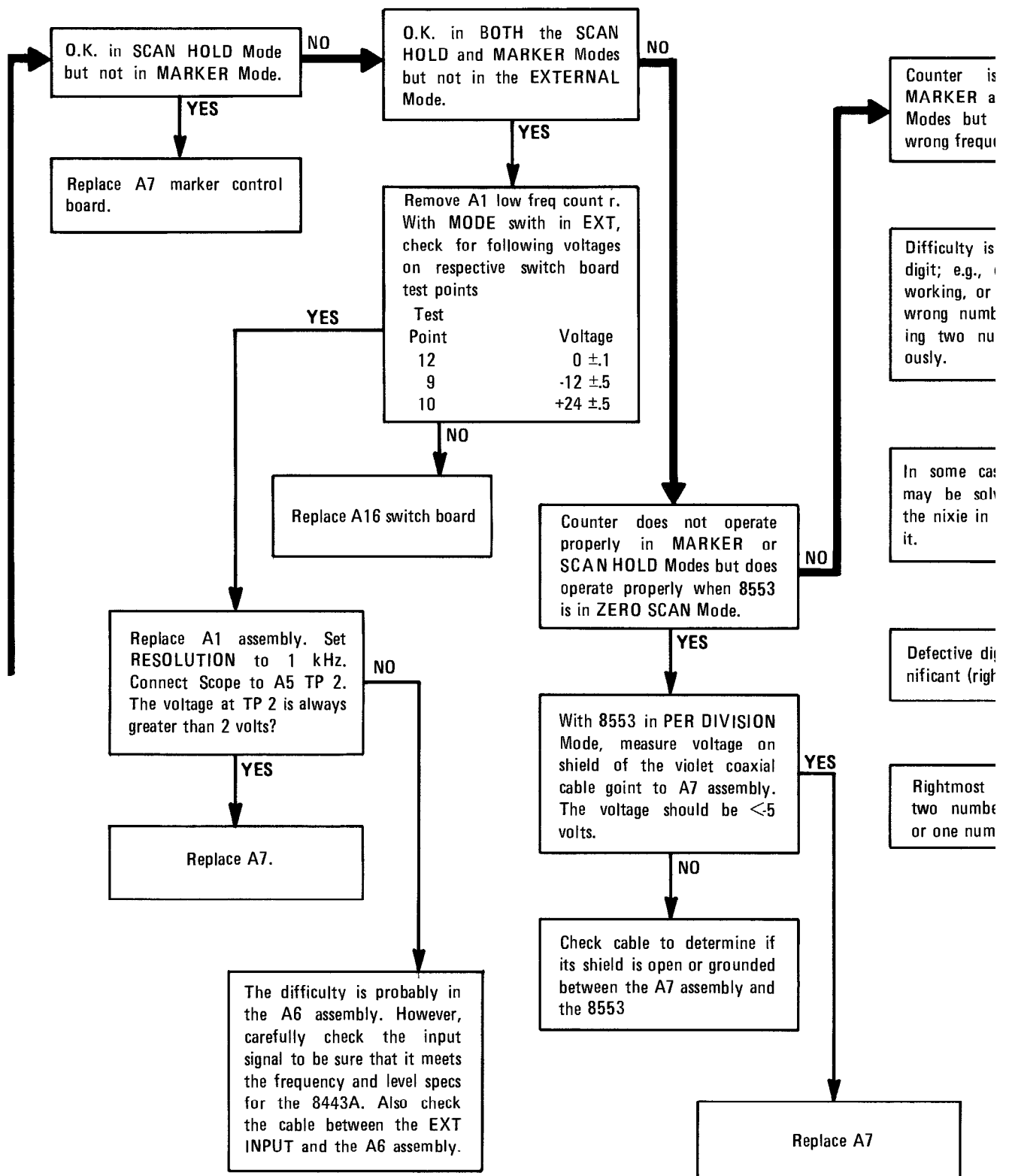
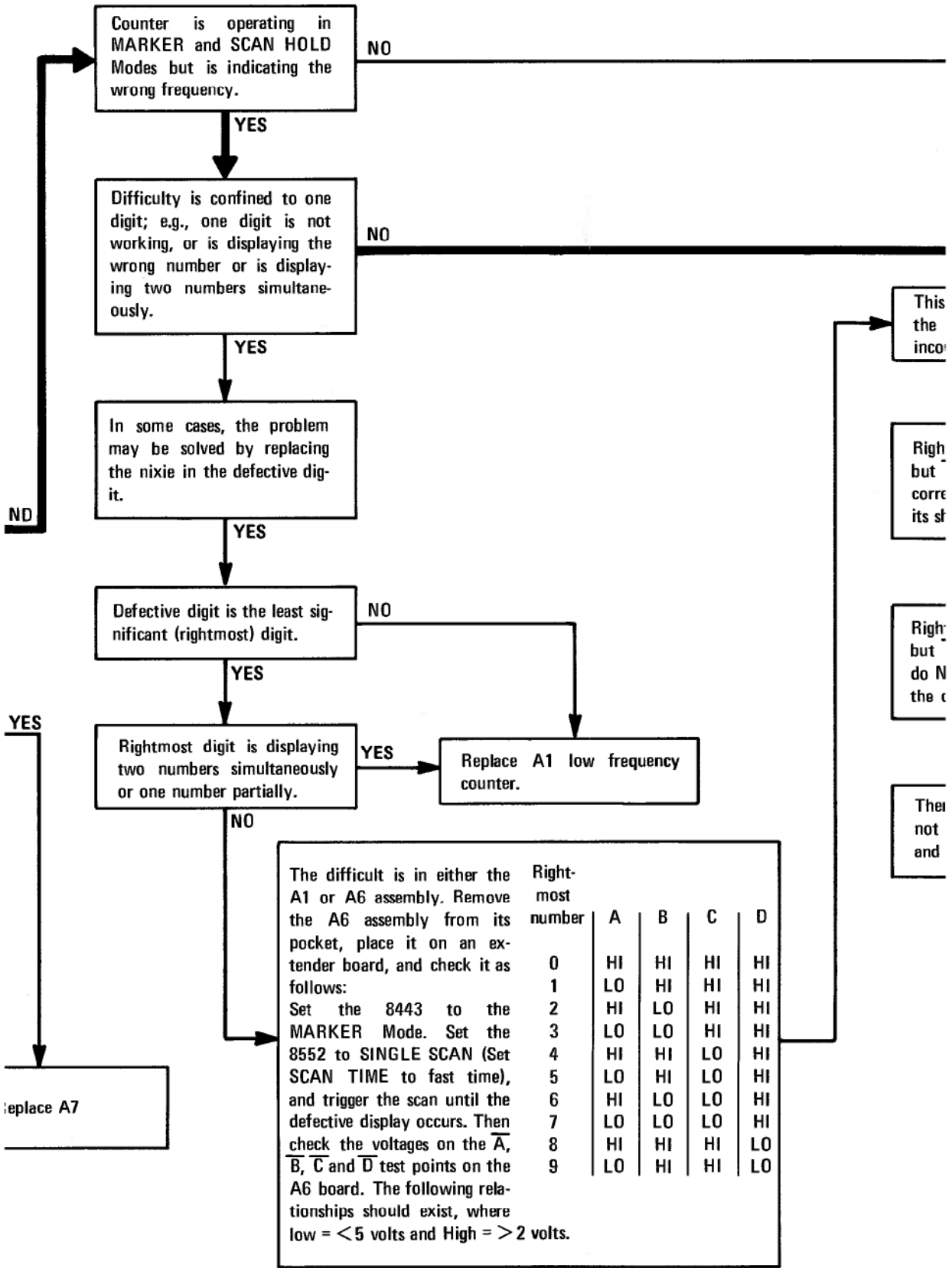

Figure 8-17. Troubleshooting Tree (Sheet 1 of 2)





This the incor

Right but corre its st

Right but do N the c

The not and

The difficult is in either the A1 or A6 assembly. Remove the A6 assembly from its pocket, place it on an extender board, and check it as follows:
 Set the 8443 to the MARKER Mode. Set the 8552 to SINGLE SCAN (Set SCAN TIME to fast time), and trigger the scan until the defective display occurs. Then check the voltages on the \bar{A} , \bar{B} , \bar{C} and \bar{D} test points on the A6 board. The following relationships should exist, where low = < 5 volts and High = > 2 volts.

Right-most number	A	B	C	D
0	HI	HI	HI	HI
1	LO	HI	HI	HI
2	HI	LO	HI	HI
3	LO	LO	HI	HI
4	HI	HI	LO	HI
5	LO	HI	LO	HI
6	HI	LO	LO	HI
7	LO	LO	LO	HI
8	HI	HI	HI	LO
9	LO	HI	HI	LO

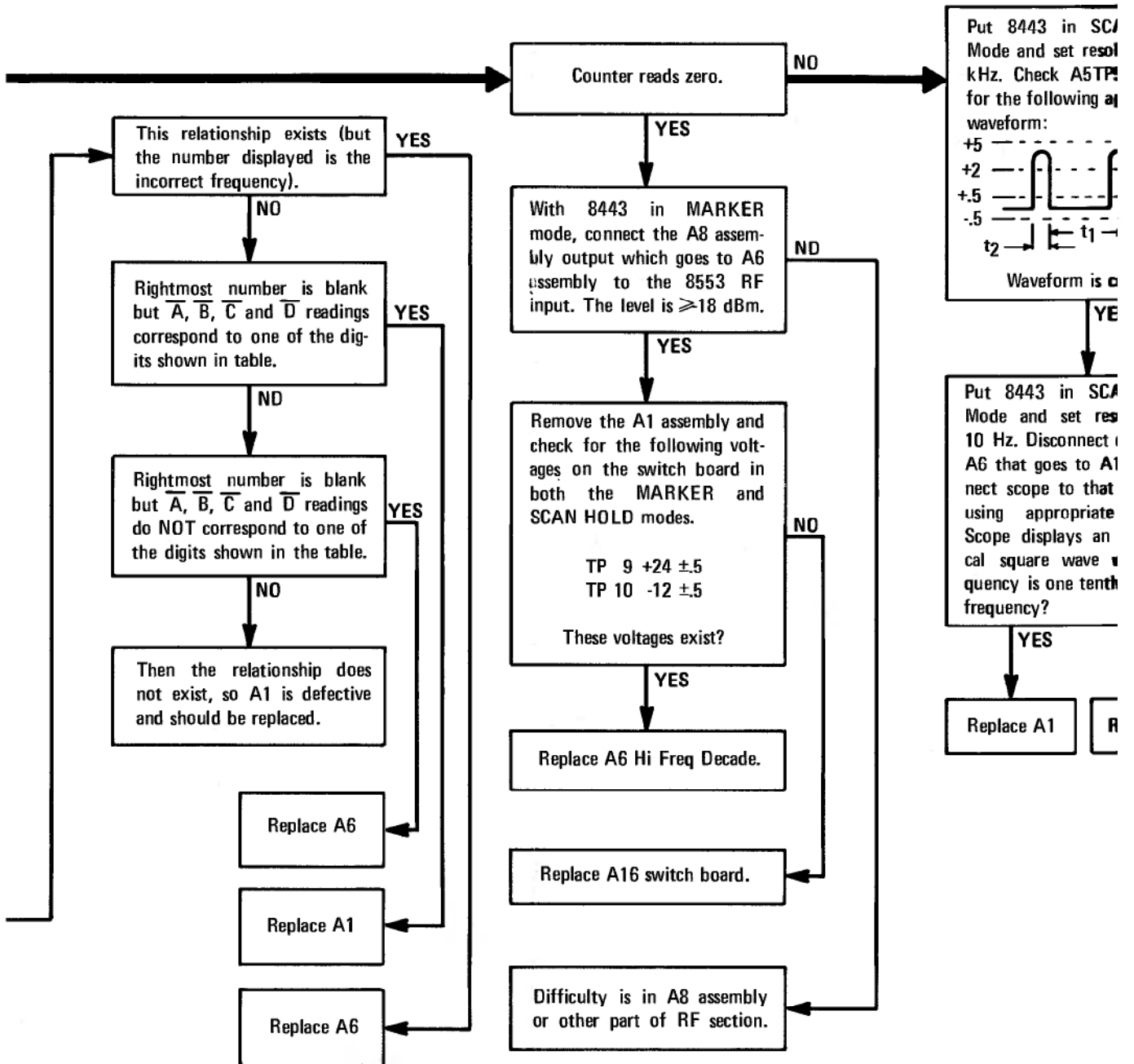

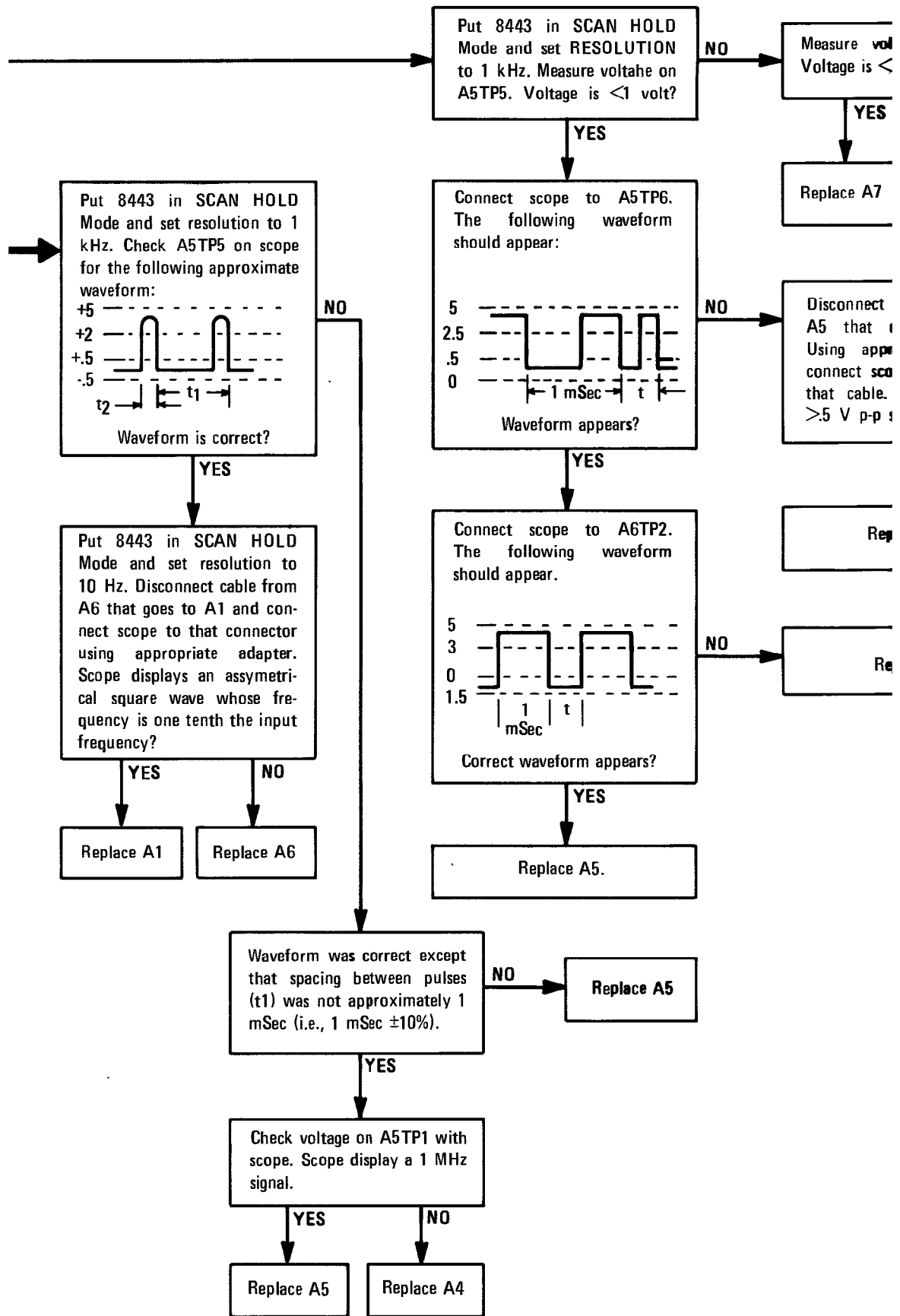

ROUBLESHOOTING TREE

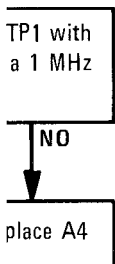
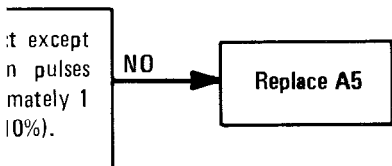
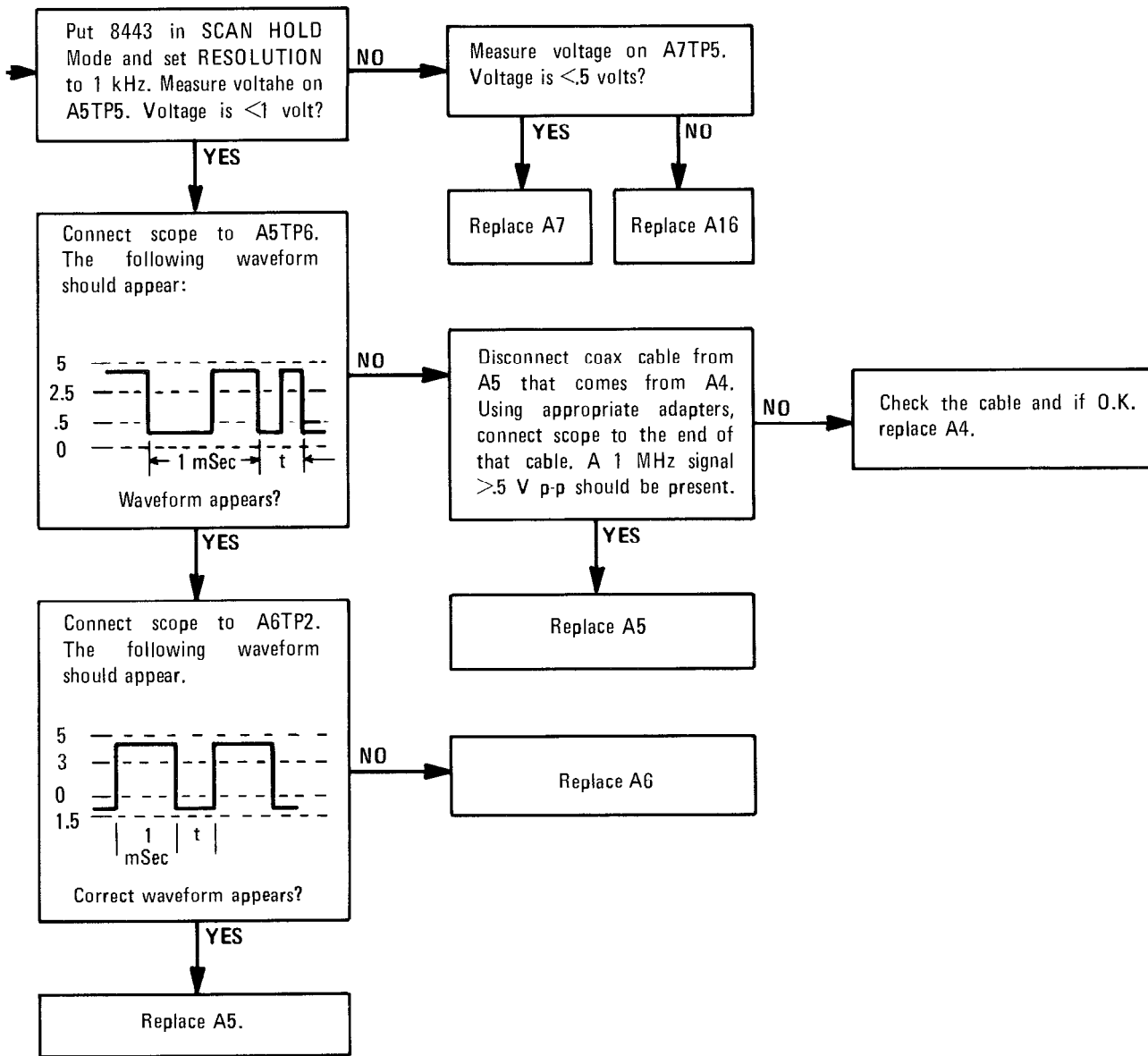

NOTES

1. Controls not mentioned in the following tests need not be adjusted. They are properly set from the previous test, or do not affect the test being made.
2. All tests are based on the model 8443A being interconnected with an analyzer which is known to be operating properly.
3. It is assumed in rf section tests that the rf output is missing or that the level and/or flatness is not as specified.
4. Since the model 8443A rf output level is largely determined by the ALC assembly, a deviation of ± 2 dB or so from that illustrated is permissible in individual tests. However, the minimum signal levels specified in each test must be met.
5. In several of the analyzer CRT displays a signal other than that shown may be observed. Usually these signals may be ignored; they are mixing products which are filtered out in later stages.
6. If the rf output is as specified and the counter section is not operating properly, or if the scan hold function is not operating properly, proceed to the "COUNTER SECTION TROUBLESHOOTING TREE".

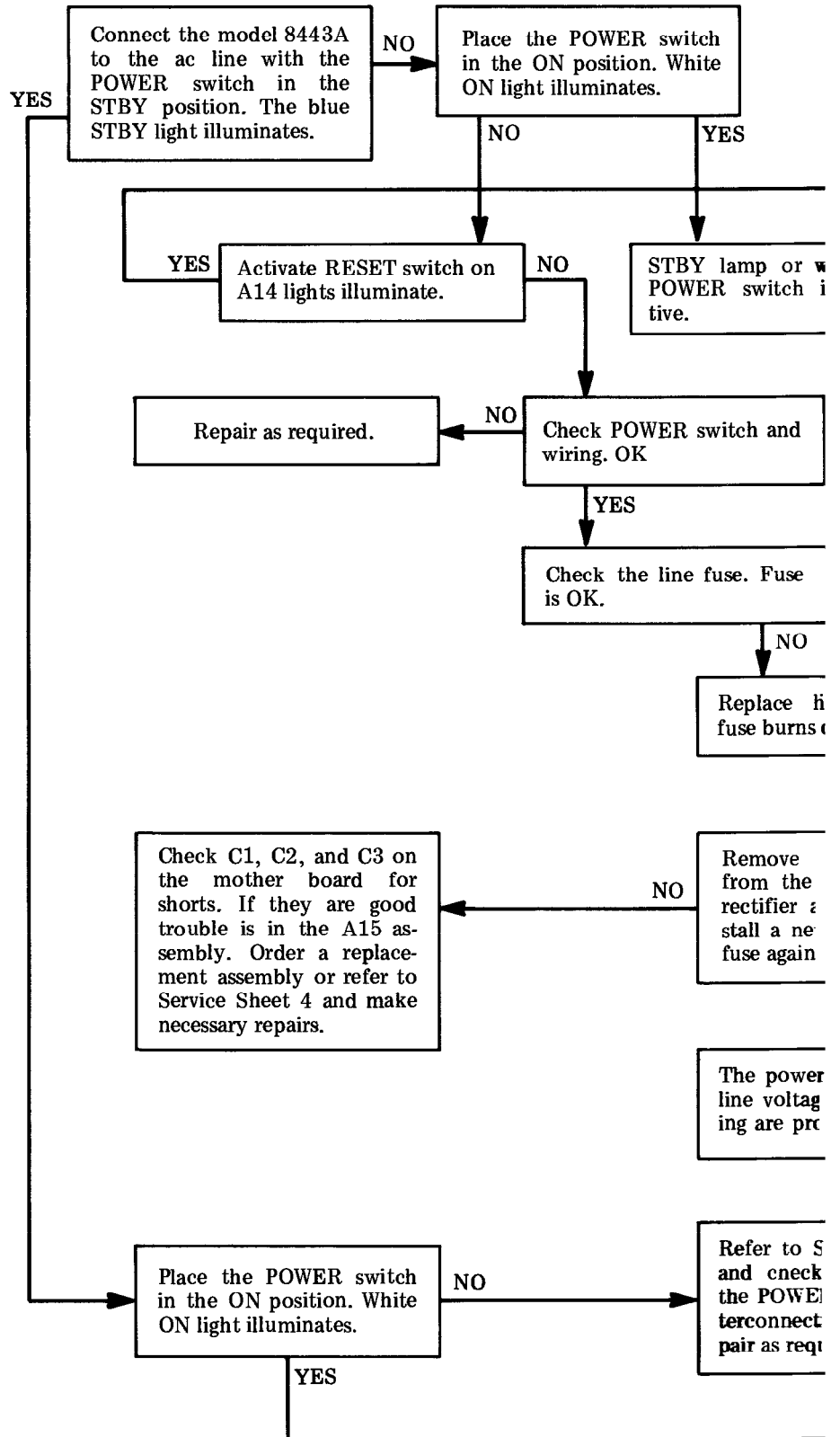

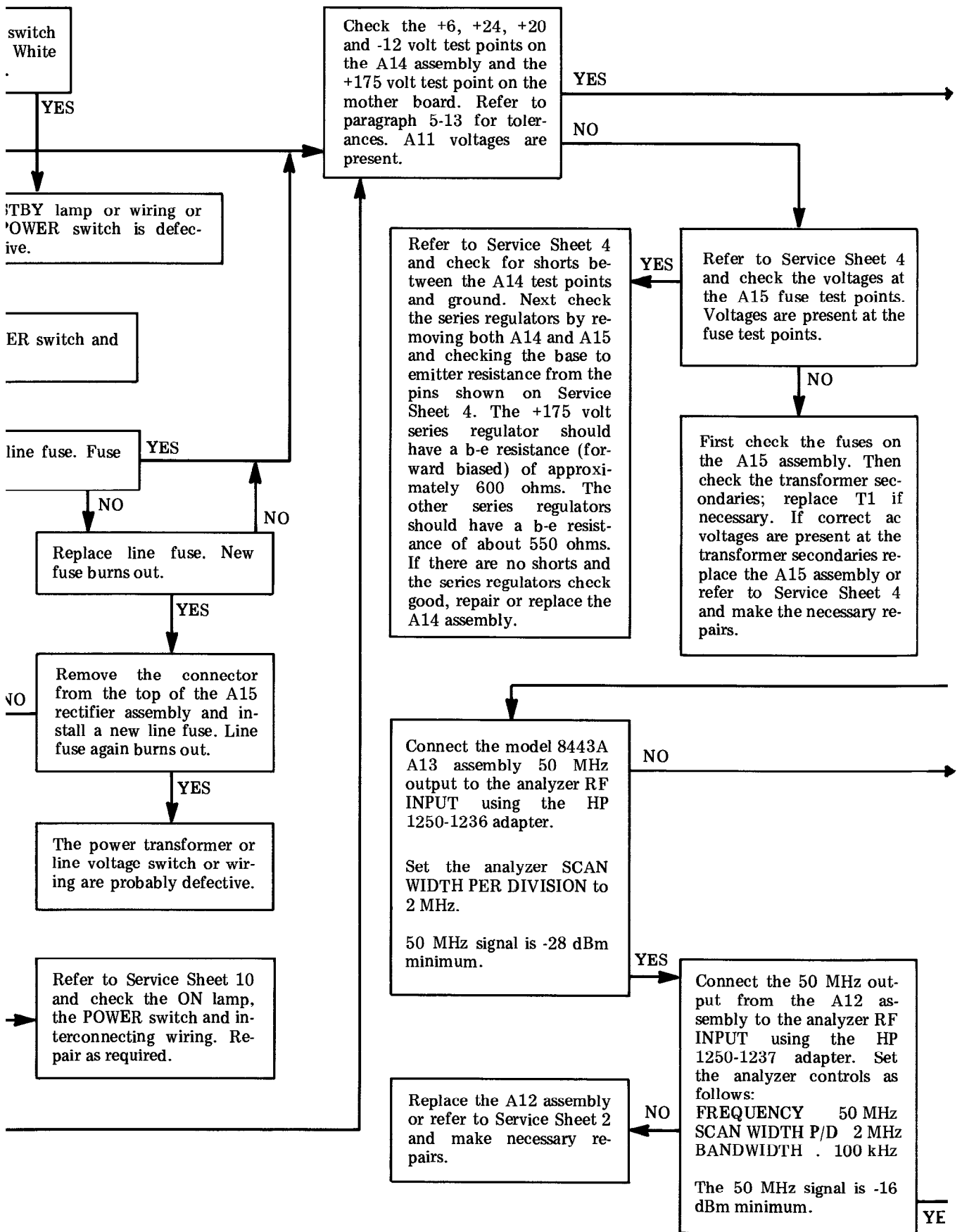

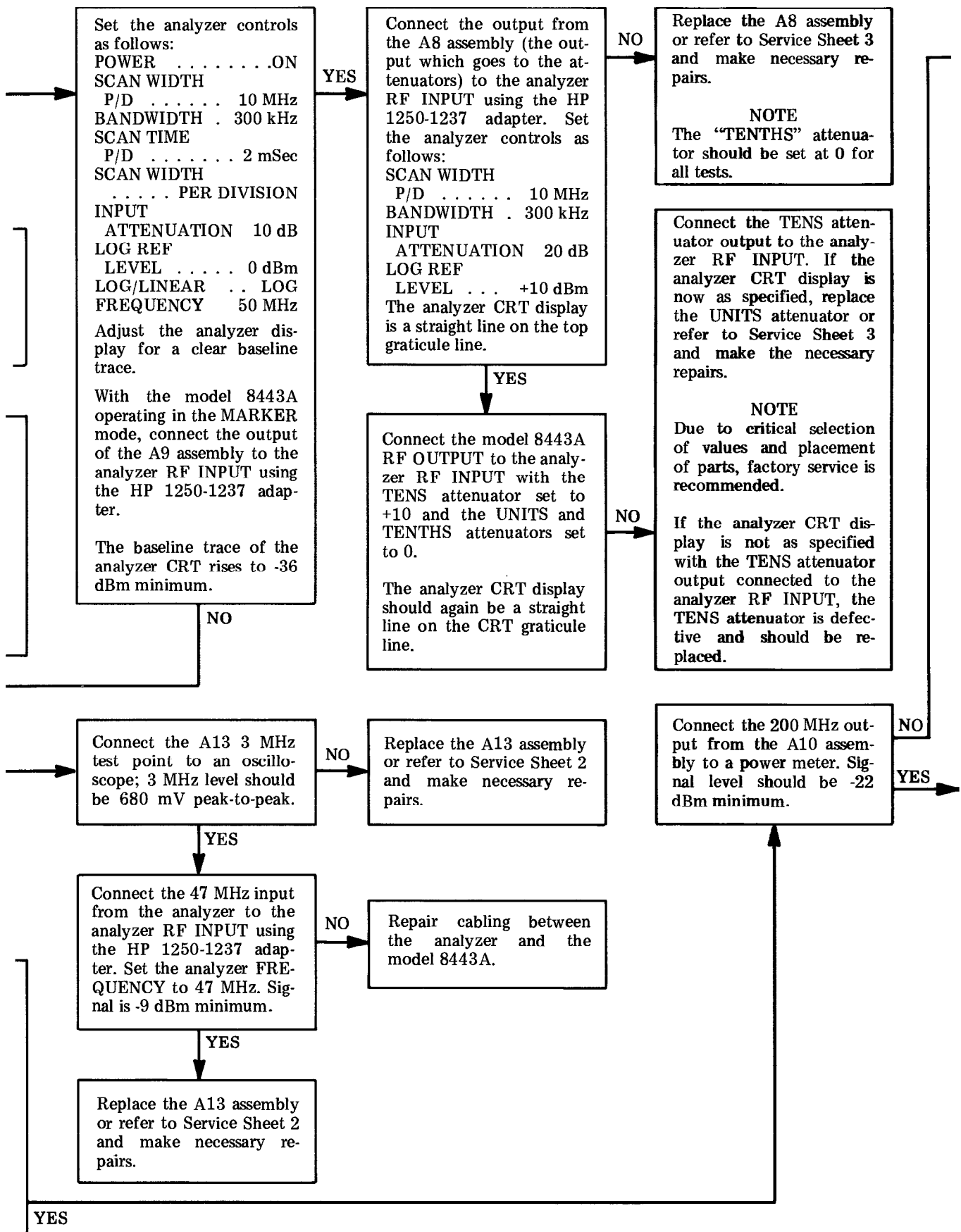

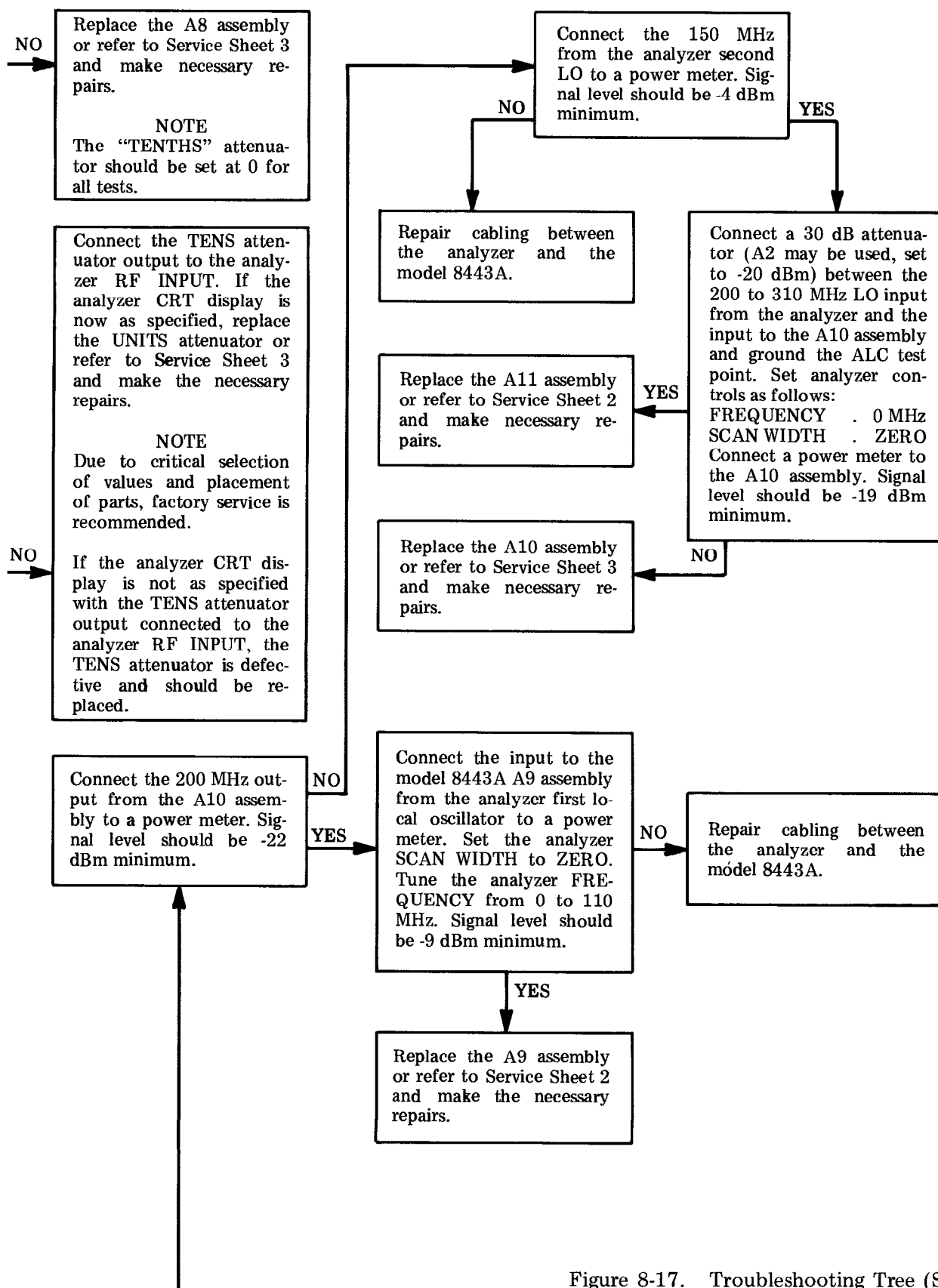

Figure 8-17. Troubleshooting Tree (Sheet 2 of 2)

Table 8-7. Assembly and Component Locations

Assembly	Schematic	Photo
A1 Low Frequency Counter	Service Sheet 9	Service Sheet 9
A2 TENS Attenuator	Service Sheet 3	Figure 8-18
A3 ONES Attenuator	Service Sheet 3	Figure 8-18
A4 Reference Oscillator	None	Figure 8-18
A5 Time Base Assembly	Service Sheet 7	Service Sheet 7
A6 High Frequency Decade	Service Sheet 8	Service Sheet 8
A7 Marker Control	Service Sheet 6	Service Sheet 6
A8 ALC/Video Amplifier	Service Sheet 3	Service Sheet 3
A9 Third Converter	Service Sheet 3	Service Sheet 3
A10 200 MHz IF Amplifier	Service Sheet 3	Service Sheet 3
A11 Second Converter	Service Sheet 2	Service Sheet 2
A12 50 MHz IF Amplifier	Service Sheet 2	Service Sheet 2
A13 First Converter	Service Sheet 2	Service Sheet 2
A14 Sense Amplifiers	Service Sheet 4	Service Sheet 4
A15 Rectifier Assembly	Service Sheet 4	Service Sheet 4
A16 Switch Assembly	Service Sheet 10	Service Sheet 10

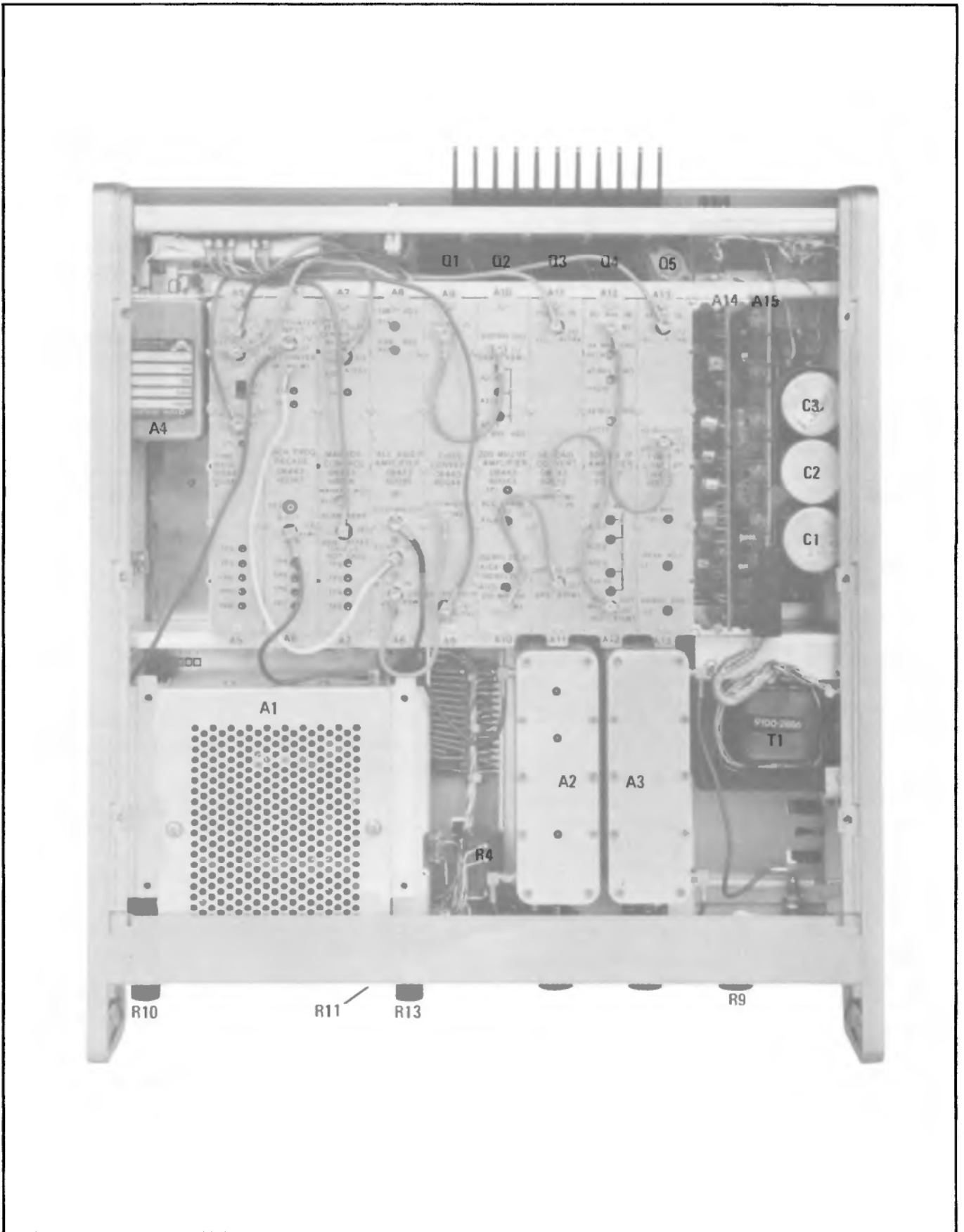

Figure 8-18. Chassis Mounted Parts and Assembly Locations

**Section VIII
Service**

SERVICE SHEET 1

General

The HP 8443A Tracking Generator/Counter was designed for use in conjunction with the HP 8553/8552 Spectrum Analyzer.

The HP 8443A output frequency is swept (or tuned to a fixed frequency) by the three local oscillators in the Spectrum Analyzer. The output frequency of the HP 8443A always tracks the frequency to which the analyzer is tuned.

The HP 8443A counter section provides a means of stopping the Spectrum Analyzer scan and counts the output frequency of the Tracking Generator while the analyzer scan is stopped. The counter may also be used to count the frequency of an external source. BCD information from the frequency counter is available at the rear of the instrument to drive external equipment.

The HP 8443A Counter Section is described in detail on Service Sheet 5.

First Converter (A13)

The first converter assembly consists of a 3 MHz crystal controlled Colpitts oscillator, a 3 MHz buffer amplifier, a 47 MHz buffer amplifier and a diode quad bridge mixer.

The 47 MHz input from the analyzer third local oscillator (approximately -7 dBm) is amplified 14 dB and applied to the bridge mixer. The other input to the bridge is the 3 MHz output of the crystal controlled Colpitts oscillator. The output from the bridge is a 50 MHz fixed frequency or, when the analyzer is operated in the stabilized mode, a swept frequency (up to 200 kHz) centered at 50 MHz. Output signal level is nominally -26 dBm. Detailed operation of the first converter and service instructions appear on Service Sheet 2.

50 MHz Amplifier (A12)

The 50 MHz amplifier consists of a two-stage (approximately 11 dB gain) amplifier and a band-pass filter.

The bandwidth of the bandpass filter at the 3 dB points is approximately 4 MHz.

Traps are provided to suppress the 47 MHz input from the analyzer and 44 MHz image response.

Detailed operation of the 50 MHz amplifier and service instructions appear on Service Sheet 2.

Second Converter (A11)

The second converter assembly consists of a three-stage amplifier and a diode quad bridge mixer.

The amplifier isolates the analyzer second local oscillator from the HP 8443A and provides approximately 20 dB of gain.

The diode quad bridge mixes the 150 MHz signal from the analyzer with the signal from the 50 MHz IF to produce an output IF signal of 200 MHz. The output level is about -38 dBm.

Detailed operation and service information is on Service Sheet 2.

200 MHz Amplifier (A10)

The 200 MHz amplifier contains a two-stage variable-gain amplifier and a bandpass filter.

The gain of the amplifier is controlled by the ALC signal from the Video Amplifier/Automatic Level Control Assembly.

The maximum gain of the 200 MHz amplifier is about 20 dB.

Detailed operation and service information appears on Service Sheet 3.

Third Converter (A9)

The third converter consists of a three-stage fixed-gain 200 to 310 MHz amplifier, a diode quad mixer and a low pass filter.

The amplifier isolates the HP 8443A from the analyzer first local oscillator and provides approximately 20 dB of gain.

The bandwidth of the frequencies processed through the amplifier is determined by the position of the SCAN WIDTH switch on the Spectrum Analyzer RF section.

When the analyzer is operated in narrow scan widths (20 kHz per division or less) in the stabilized mode, the analyzer first local oscillator output is a fixed frequency. (The analyzer third local oscillator is swept when the first local oscillator is not.)

The diode quad mixer mixes the input from the analyzer first local oscillator and the output from the 200 MHz amplifier to produce a 0 to 110 MHz signal or any portion of this range of frequencies. When the analyzer is operated in the ZERO scan mode the output from the mixer is a fixed frequency.

The 120 MHz low pass filter provides approximately 75 dB rejection to frequencies above 200 MHz. The 3 dB cutoff point is at 120 MHz. Detailed operation and service information appears on Service Sheet 3.

Video Amplifier/ALC (A8)

The Video Amplifier/ALC (automatic level control) circuit consists of two amplifiers and a comparator. The input video amplifier provides 32 dB of gain and the second amplifier provides 20 dB of gain.

The comparator is referenced to a fixed level which is controlled by the 0 to 1.2 dB vernier to provide the automatic level control signal to the 200 MHz amplifier.

When the 0 to 1.2 dB vernier is set to 0 the RF output to the 0 to 120 dB attenuator is a constant +10 dBm. The 0 to 1.2 dB vernier may be used to attenuate the RF output linearly from 0 to 1.2 dB. Detailed operation and service information appears on Service Sheet 3.

RF Attenuators (A2 and A3)

There are two precision step attenuators connected in series with the RF output. The first is a

0 to 120 dB, 10 dB per step attenuator. The second is a 0 to 12 dB, 1 dB per step attenuator. These attenuators, in conjunction with the 0 to 1.2 dB vernier provide accurate control of the output signal at any level between +10 dBm and -123.2 dBm. Detailed operation and service information appears on Service Sheet 3.

Power Supplies and Regulators (A14 and A15)

All dc power supplies use a common power transformer and all are referenced to the +24 volt supply.

When the instrument is in the standby mode the +24 volt supply functions to maintain crystal oven temperature and avoid long warmup periods when the instrument is placed in service. In the standby mode all other power supplies are disabled.

The regulated power supplies provide +170, +24, +20, +6 and -12 volts. A zener circuit in the high frequency decade (A5) reduces the -12 volt level to -6 volts for use in counter circuits.

Silicon controlled rectifier "crowbar" protection is provided for the +24, +20, +6 and -12 volt regulators. A reset feature is provided to reset the "crowbar" should it be tripped by a transient.

Current limiting circuits provide further protection for the 8443A circuits. Detailed operation and service information appears on Service Sheet 4.

Counter Circuits

The counter circuits are discussed on Service Sheet 5 and Service Sheets for the individual counter section circuits.

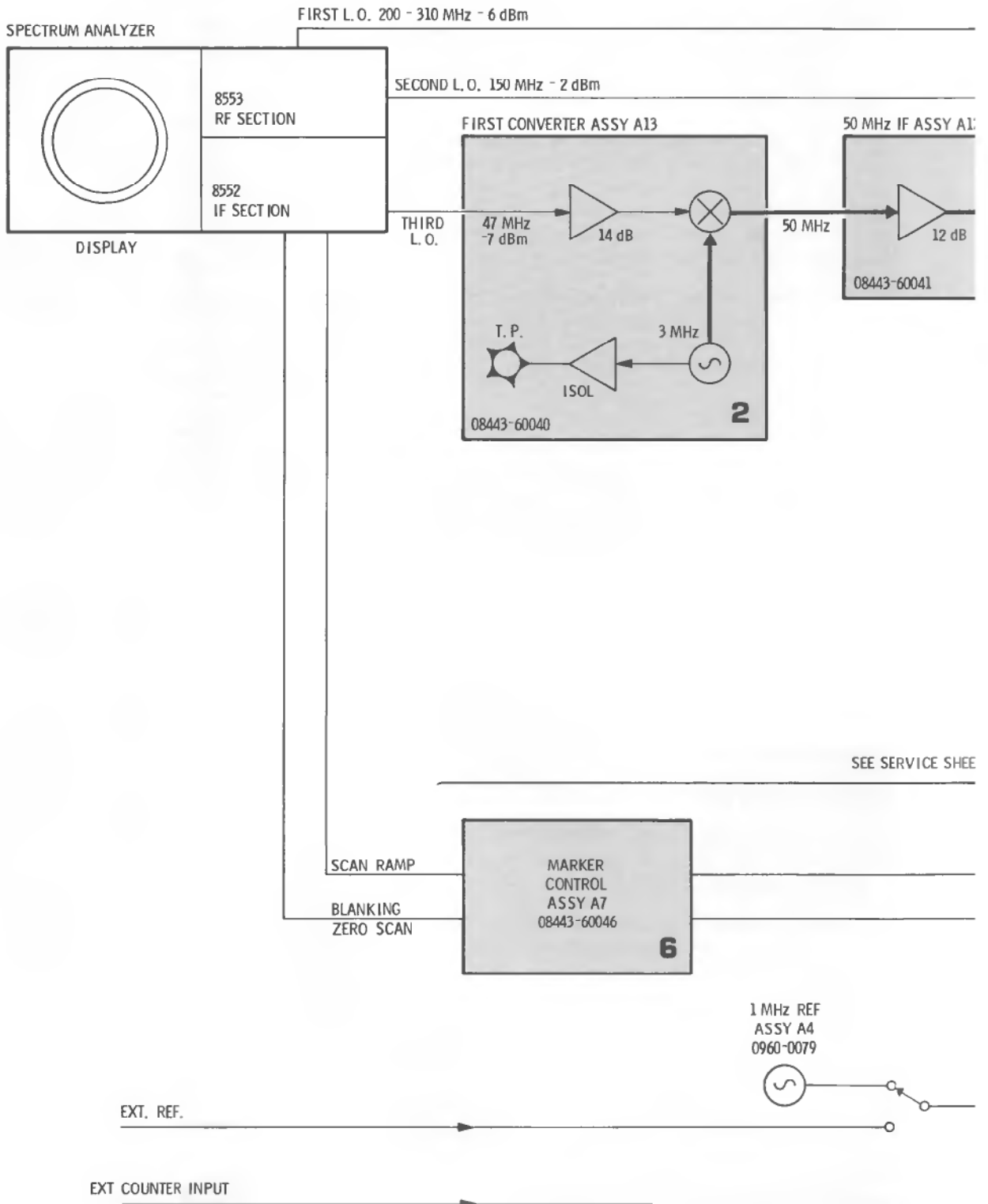

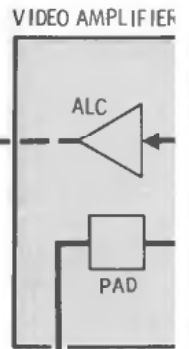
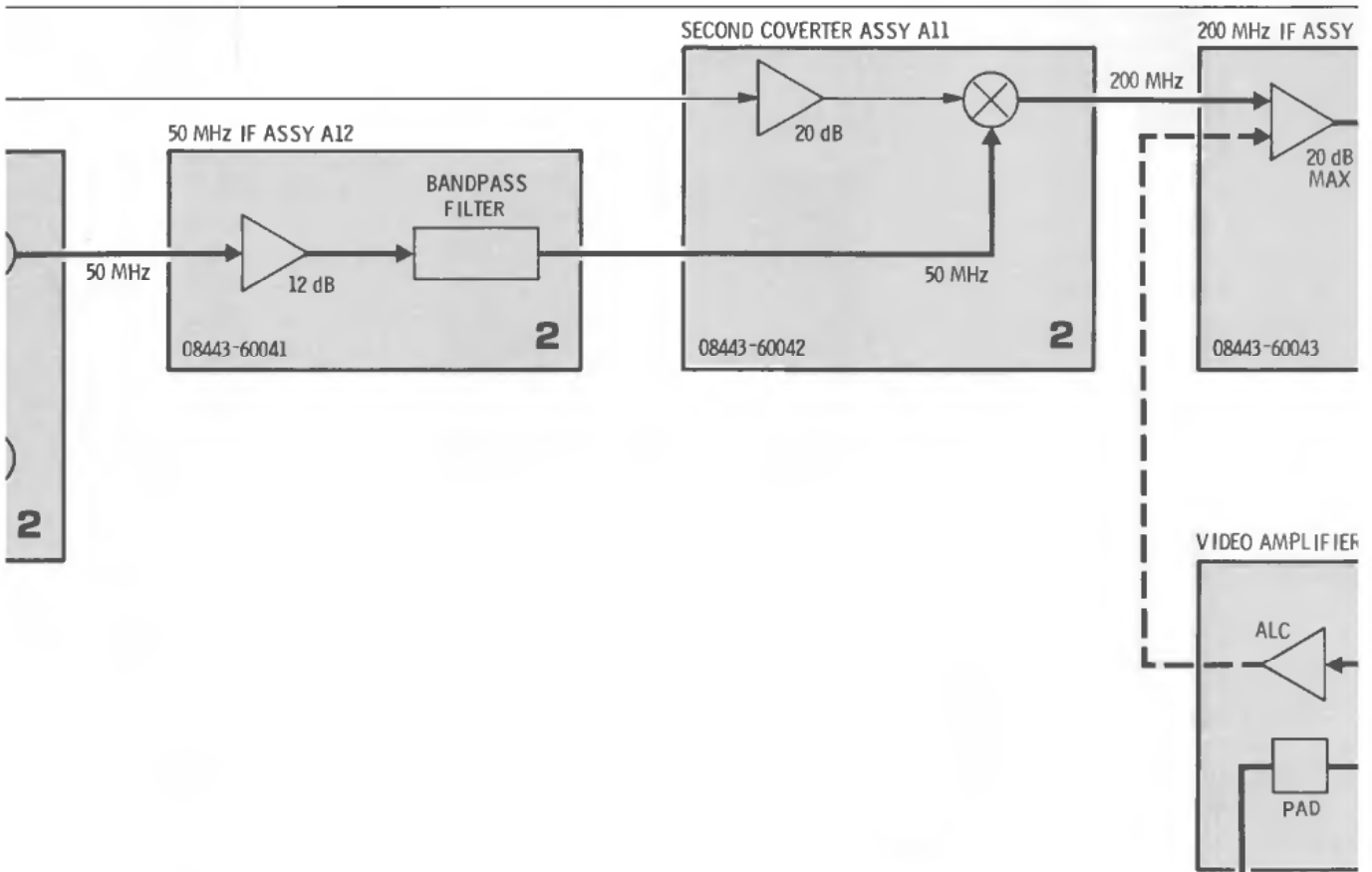

SEE SERVICE SHEET 5 FOR COUNTER LOGIC

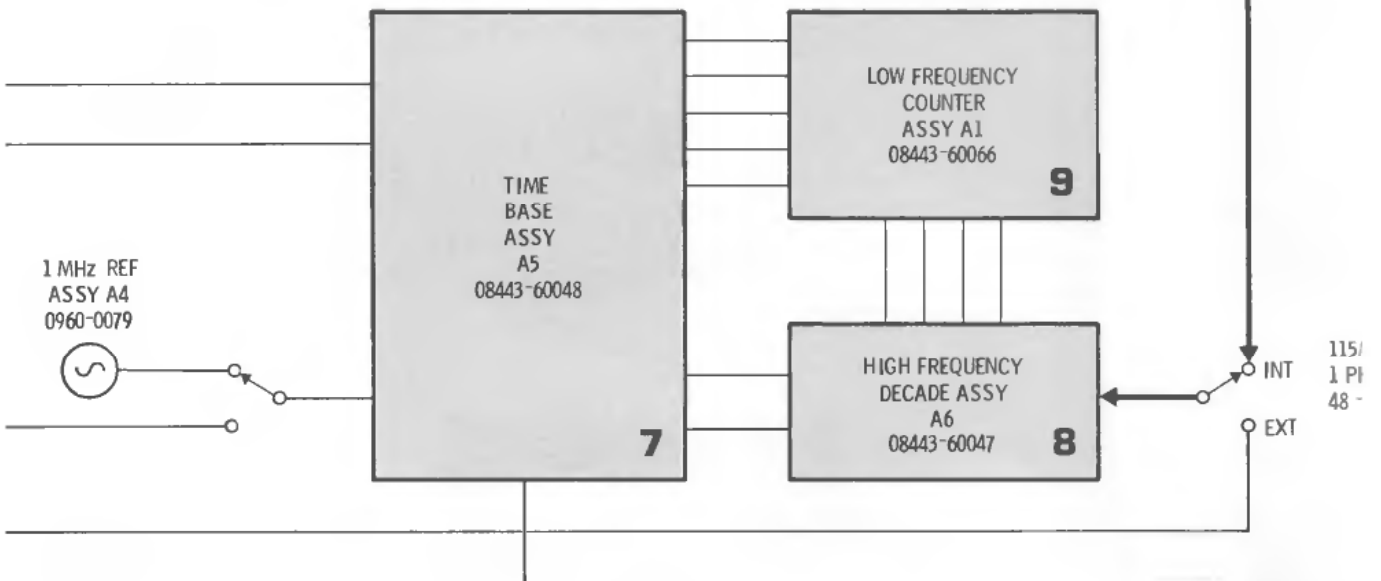

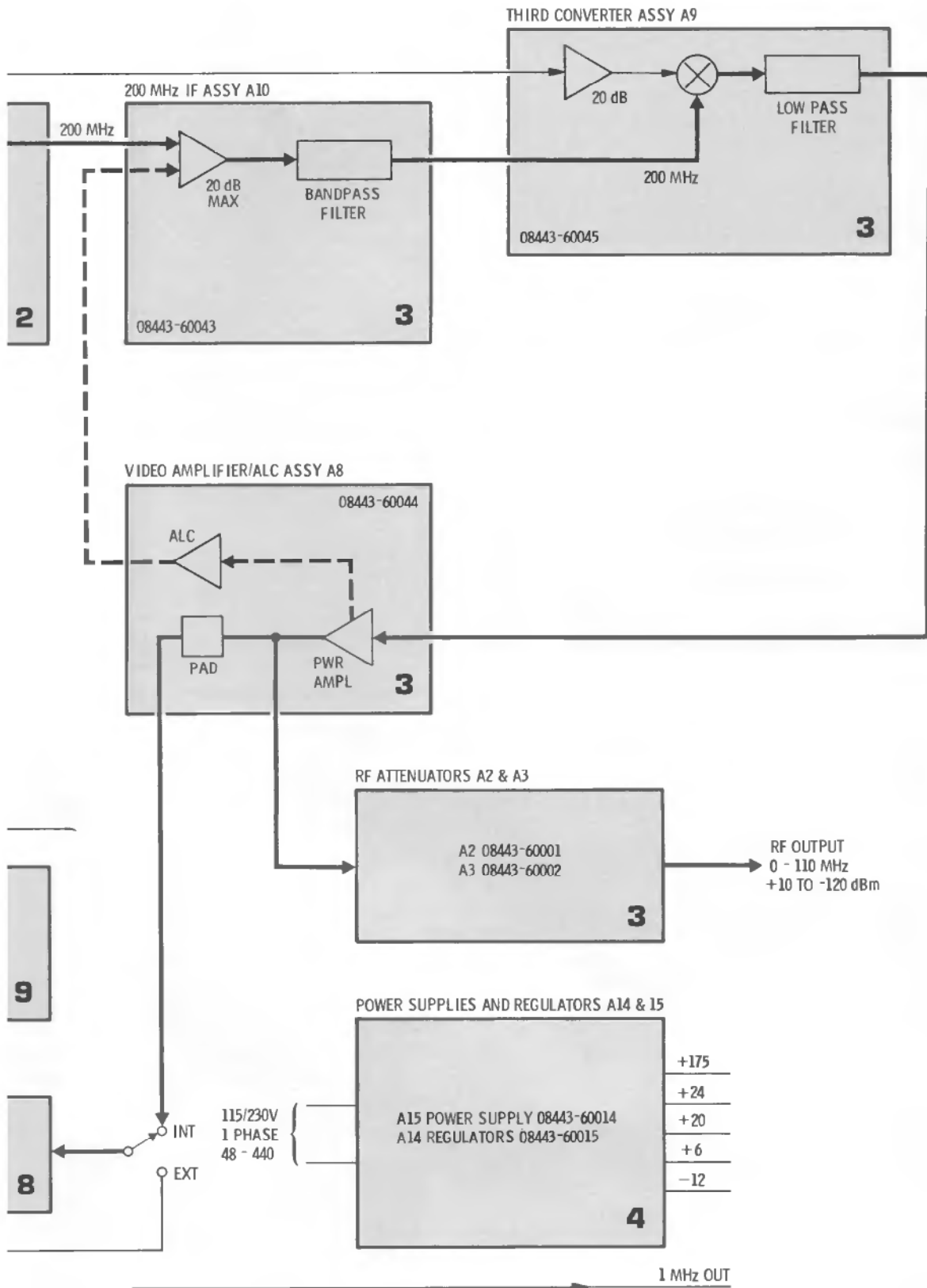

1

Figure 8-19. Overall Block Diagram

SERVICE SHEET 2

Normally, the cause of a malfunction in the model 8443A will be isolated to a circuit board or assembly as a result of performing the tests specified in the Troubleshooting Tree.

When trouble has been isolated to a specific circuit, the circuit board should be removed and re-installed using an extender board, to provide easy access to test points and components.

All tests are based on the assumption that the model 8443A is interconnected with an 8553/8552/140 Spectrum Analyzer which is known to be operating properly.

Equipment Required:

- | | |
|---------------------------------|------------------|
| Digital Voltmeter | Service Kit |
| Shielded Probe | BNC Tee |
| Dummy Load | BNC to BNC Cable |
| 0 to 1250 MHz Spectrum Analyzer | |

Spectrum Analyzer Control Settings:

- | | |
|-------------------|-----------------------|
| Power | ON |
| DISPLAY CONTROLS | Set for clear display |
| SCAN WIDTH | |
| PER DIVISION | 2 MHz |
| SCAN WIDTH | PER DIVISION |
| BANDWIDTH | 300 kHz |
| INPUT ATTENUATION | 10 dB |
| LOG REF LEVEL | 0 dBm |
| LOG/LINEAR | LOG |
| SCAN TIME | |
| PER DIVISION | 20 MILLISECONDS |
| VIDEO FILTER | OFF |

Tracking Generator/Counter Control Settings:

- | | |
|------------|-----------------------|
| POWER | ON |
| MODE | MARKER |
| RESOLUTION | ANY |
| RF OUTPUT | |
| LEVEL dBm | All controls set to 0 |

Note

In individual tests only those controls mentioned need to be changed. Other control settings are compatible with previous tests.

1 First Converter Assembly A13

The first converter assembly consists of a 3 MHz crystal controlled oscillator, a 47 MHz buffer amplifier, a diode quad bridge and a 3 MHz buffer amplifier.

The 3 MHz oscillator is a Colpitts crystal controlled oscillator with a varactor as a fine fre-

quency control element. Since a decrease in the capacity of the varactor results in an increase in oscillator frequency, inductor L4 is tuned as required to lower the frequency and center the range of the varactor control. The frequency is variable by the varactor approximately 400 Hz. The 3 MHz oscillator supplies approximately 12 mVolts to one side of the diode quad mixer. A buffer stage is provided which isolates the 3 MHz test point to prevent loading the circuit when measurements are taken during maintenance.

The 47 MHz buffer isolates the spectrum analyzer third local oscillator from the model 8443A and provides about 14 dB of gain. When the analyzer is operated in wide scan modes (unstabilized) the 47 MHz signal from the analyzer is a fixed frequency. When the analyzer is operated in narrow scan width modes (stabilized) the 47 MHz signal is swept in frequency.

The diode quad mixer is a conventional mixer which accepts the 3 MHz and 47 MHz signals and produces a 50 MHz output. (When the analyzer is operated in narrow scan stabilized modes the bridge output is swept, in frequency, by an amount determined by the setting of the SCAN WIDTH control on the analyzer.)

Test Procedure 1

Test 1-a. Use the digital voltmeter to verify the presence of -12 volts and +20 volts at terminals shown on the schematic diagram.

Test 1-b. Connect the 50 MHz output from the A13 assembly to the analyzer RF INPUT. Pull the model 8443A MARKER POSITION control knob away from the front panel to center the marker. Tune the analyzer to a center frequency of 50 MHz and center the 50 MHz signal on the CRT. A CRT presentation similar to waveform SS2-1 should be observed. If the correct waveform is observed the assembly is operating properly. If the CRT presentation is not correct, proceed to test 1-c.

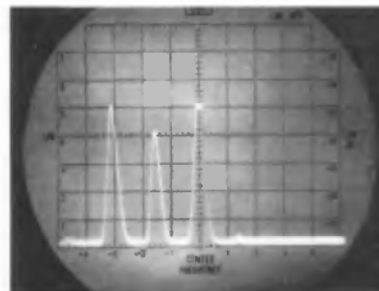

Waveform SS2-1

Note

When a malfunction is found and corrected in any of the following steps, repeat test 1-b.

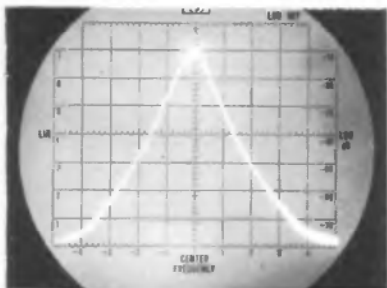

Waveform SS2-2

Test 1-c. Connect the 47 MHz input to the A13 assembly from the analyzer to the analyzer RF INPUT. Tune the analyzer to 47 MHz. Set analyzer SCAN WIDTH to .2 MHz. A presentation similar to SS2-2 should be observed on the analyzer CRT. If the CRT presentation is correct, proceed to test 1-d. If not, check the wiring to the analyzer.

Test 1-d. Connect Test Point 2 (Q2-c) to the analyzer RF INPUT and monitor the analyzer CRT for a display similar to that shown in waveform SS2-3. If the CRT display is correct, proceed to test 1-f. If not, proceed to test 1-e.

Test 1-e. Connect Test Point 3 (Q1-c) to the analyzer RF INPUT and monitor the analyzer CRT for a display similar to, but about 10 dB less than, waveform SS2-3. If the display is correct check Q2 and associated components. If the display is not correct check Q1 and associated components.

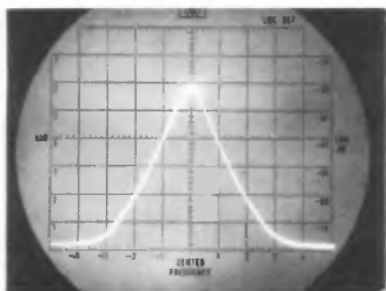

Waveform SS2-3

Test 1-f. Connect Test Point 1 to the analyzer RF INPUT and tune the analyzer to display the 3 MHz signal. The CRT display should be similar to waveform SS2-3. Proceed to test 1-g.

Test 1-g. Connect Test Point 4 to the analyzer RF INPUT. The analyzer CRT display should be similar to waveform SS2-3. If the display is not present check Q4 and associated components. If the display is present, but was not present in test 1-f, check Q3 and associated components.

If the cause of the malfunction has not been found in any of the preceding tests, trouble is probably T1, T2 or the diode quad. Repair as required and repeat test 1-b.

Note

After repairing the first converter assembly it should be adjusted in accordance with instructions in paragraph 5-14 of this manual to assure reliable operation of the instrument.

2 50 MHz IF Amplifier Assembly A12

The 50 MHz amplifier assembly consists of a two-stage amplifier and a bandpass filter. Gain of the amplifier is approximately 12 dB. The bandwidth of the 50 MHz bandpass filter at the 3 dB points is about 4 MHz. L3/C6/C8 and L6/C15/C17 are 44 MHz traps. L5/C9/C10 is a 47 MHz trap.

Test Procedure 2

Test 2-a. Use the digital voltmeter to verify the presence of +20 volts at terminals shown on the schematic diagram. Proceed to test 2-b.

Test 2-b. Connect the 50 MHz output from the A12 assembly to the analyzer RF INPUT and tune the analyzer to 50 MHz. Set the analyzer SCAN WIDTH to .2 MHz/DIV. The analyzer CRT display should be similar to that of waveform SS2-2. If the display is correct the assembly is functioning properly. If not, proceed to test 2-c.

Test 2-c. Connect Test Point 1 to the analyzer RF INPUT (be sure to ground the coax shield at the A12 assembly). The analyzer CRT display should be similar to that of waveform SS2-2 (about -14 dB). If the analyzer display is correct, proceed to test 2-d. If not, the bandpass filter is probably defective.

Test 2-d. Connect Test Point 2 (Q1-c) to the analyzer RF INPUT. A waveform similar to that shown in waveform SS2-3 should appear on the analyzer CRT (about -27 dB). If the waveform is not present check Q1 and associated components.

If the waveform is present but was not in test 2-c, check Q2 and associated components. Repeat test 2-b.

Note

After repairing the 50 MHz amplifier assembly it should be adjusted in accordance with instructions in paragraph 5-15 of this manual to assure reliable operation of the instrument.

3 Second Converter Assembly A11

The second converter assembly contains a three-stage amplifier and a diode quad bridge mixer. The amplifier isolates the analyzer second local oscillator from the model 8443A and provides about 20 dB of gain. The diode quad bridge mixes the 150 MHz signal from the analyzer with the 50 MHz signal from the 50 MHz amplifier to produce an output rf signal of 200 MHz.

Test Procedure 3

Test 3-a. Use the digital voltmeter to verify the presence of +20 volts at terminals shown on the schematic diagram.

Test 3-b. Connect the 200 MHz output from the A11 assembly to the 0 to 1250 MHz analyzer RF INPUT. Be sure that coax shield is grounded at the A11 assembly. Set the 0 to 1250 MHz analyzer controls to the same positions as the controls on the 8553/8552/140 except set SCAN WIDTH to .5 MHz/DIV. The 0 to 1250 MHz analyzer CRT should be similar to SS2-4. If the correct display is observed, the A11 assembly is functioning properly. If not, proceed to test 3-c.

Test 3-c. Connect Test Point 1 (Q3-c) to the 0 to 1250 MHz analyzer RF INPUT and tune the analyzer to 150 MHz. The analyzer display should be similar to waveform SS2-5. If the correct display is observed trouble is probably in the

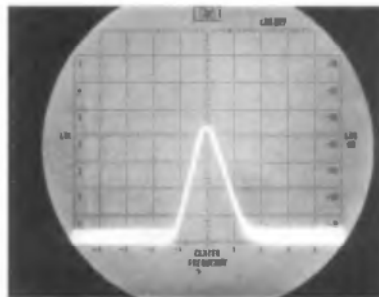

Waveform SS2-4

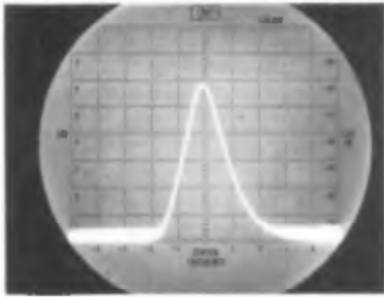

Waveform SS2-5

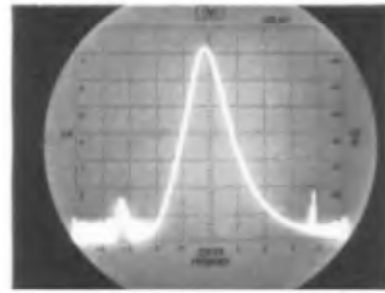

Waveform SS2-6

diode quad bridge mixer or associated components. Repair and repeat test 3-b. If the correct display is not observed, proceed to test 3-d.

Test 3-d. Connect Test Point 2 (Q2-c) to the 0 to 1250 MHz analyzer RF INPUT. The analyzer display should be similar to waveform SS2-6. If the display is correct, check Q3 and associated components and repair as required. After repairs perform test 3-b. If the correct waveform is not observed, proceed to test 3-e.

Test 3-e. Connect Test Point 3 (Q1-c) to the 0 to 1250 MHz analyzer RF INPUT. The analyzer display should be similar to waveform SS2-5 (about 3 dB lower). If the display is correct, check Q2 and associated components. After re-

pairs repeat test 3-b. If the display is not correct proceed to test 3-f.

Test 3-f. Connect the 150 MHz input from the analyzer to the RF INPUT of the 0 to 1250 MHz analyzer. The CRT display should be similar to that shown in waveform SS2-6. If the waveform is correct check Q1 and associated components. If the waveform is not correct check the wiring to the analyzer. After repairs repeat test 1-b.

Note

After repairing the second converter it should be checked in accordance with paragraph 5-16 of this manual to assure reliable operation of the instrument.

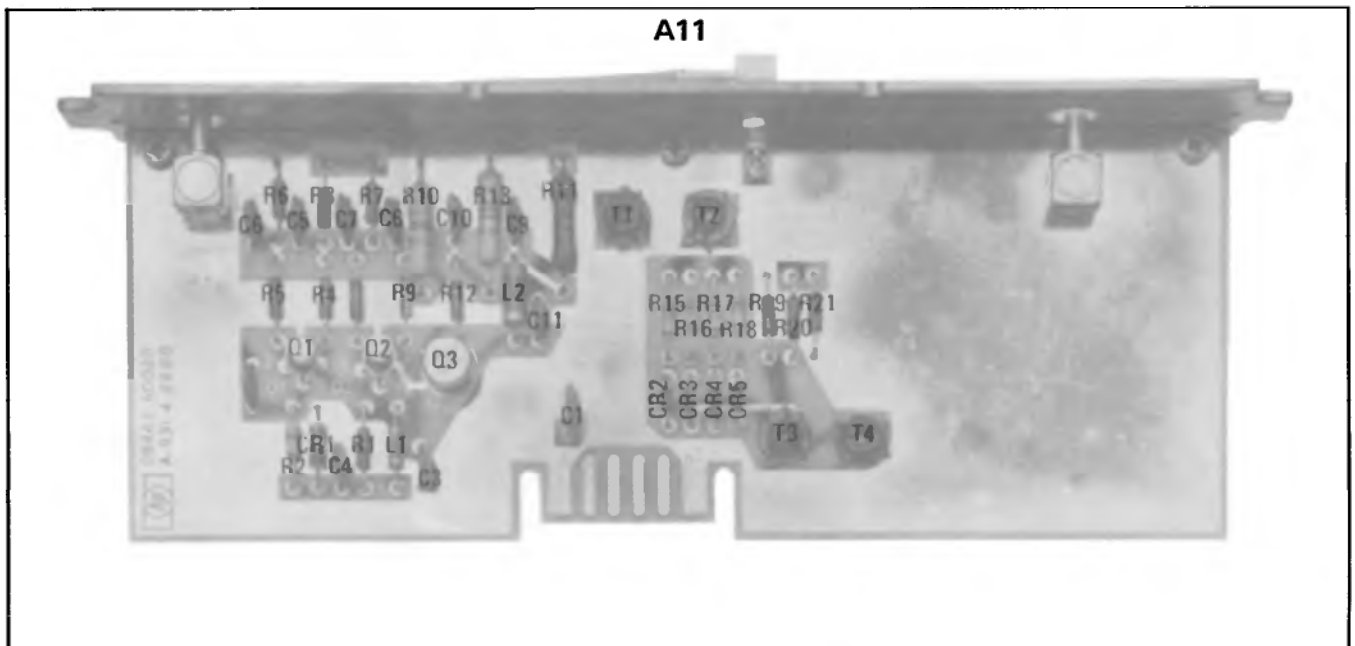
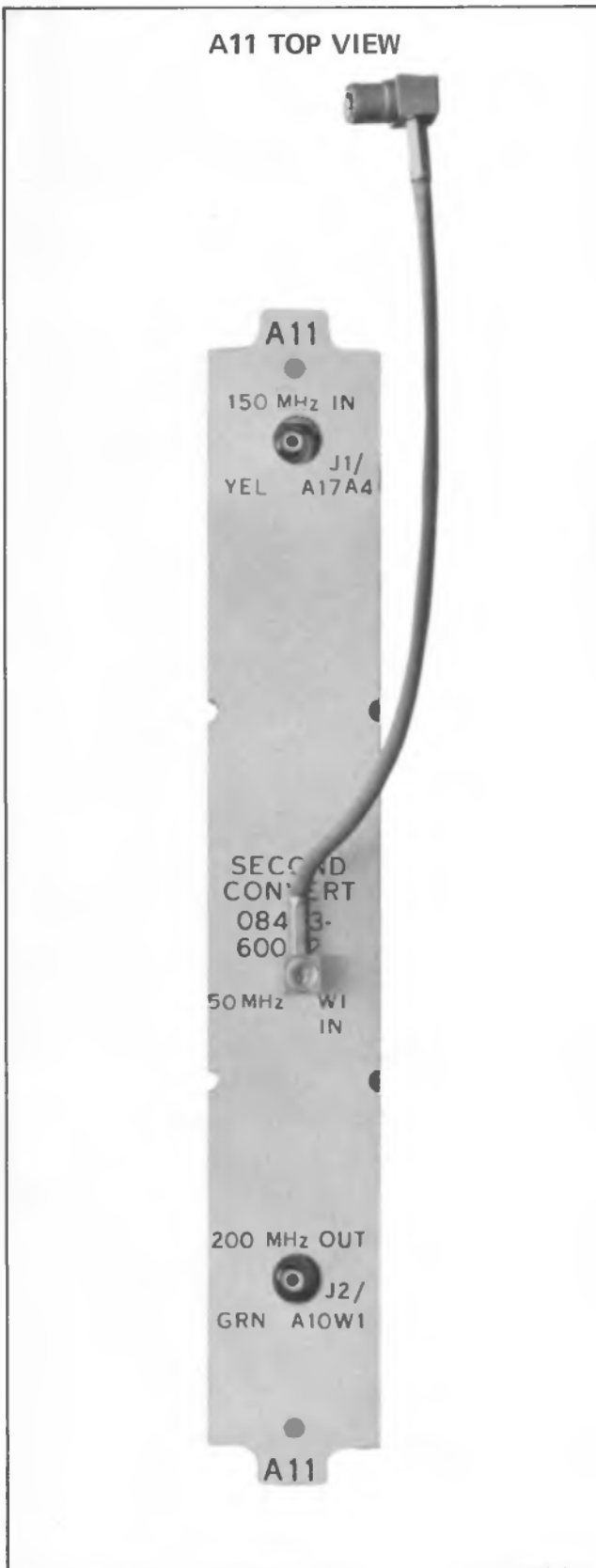

Figure 8-20. A11 Second Converter, Cover and Components

◀ **SERVICE SHEET 1**
Overall Block Diagram

A11 TOP VIEW



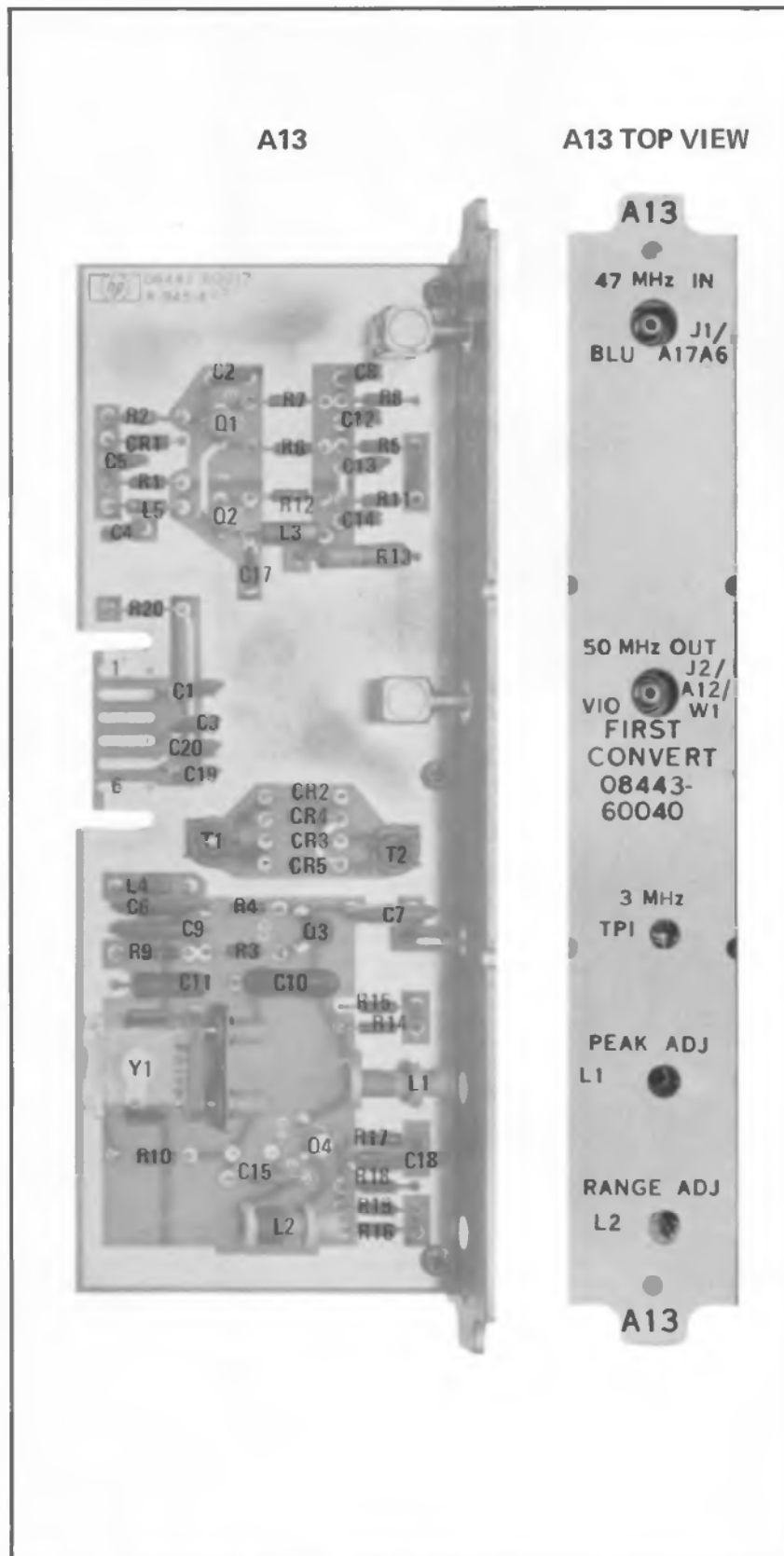

Figure 8-21. A13, First Converter, Cover and Components

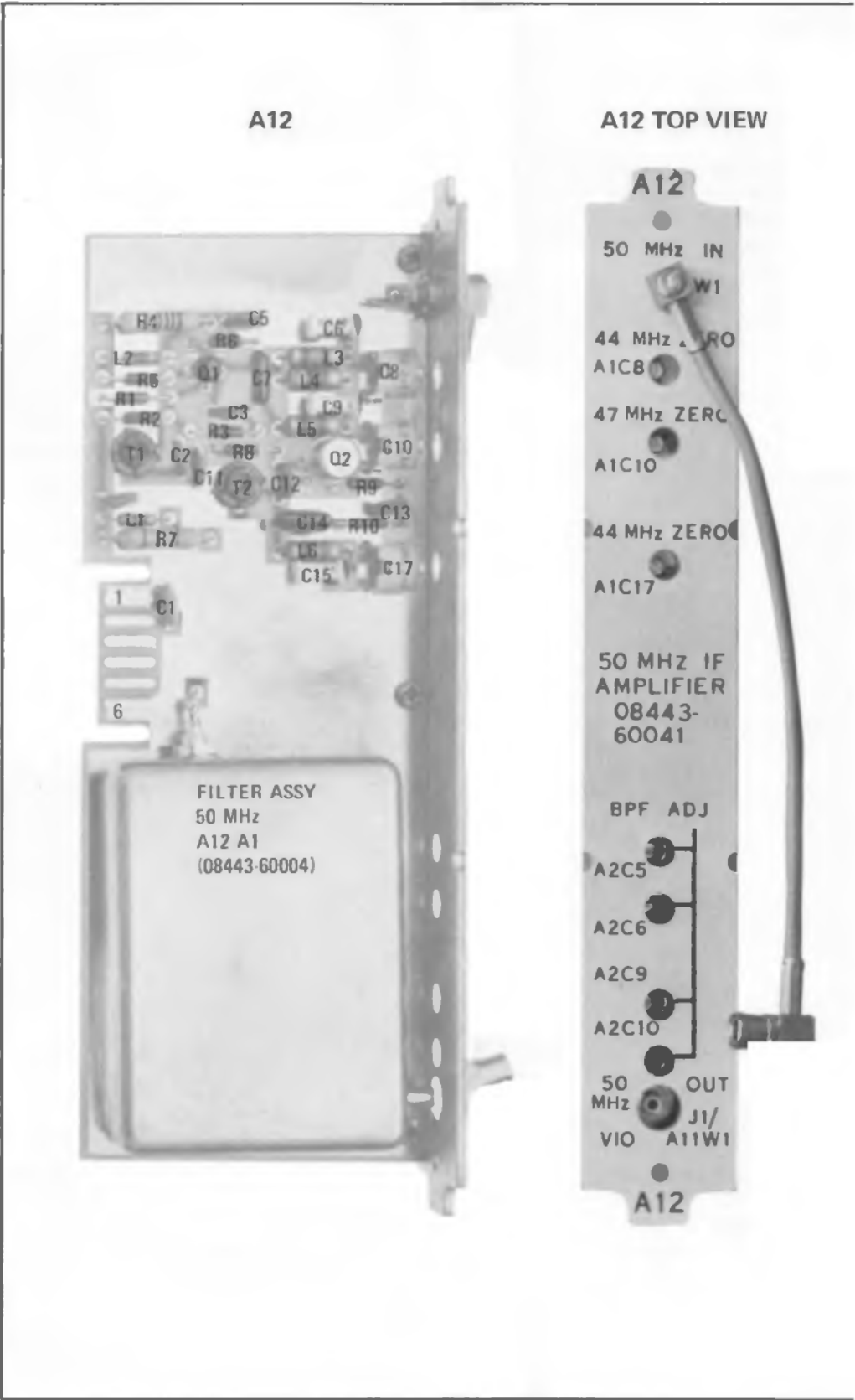
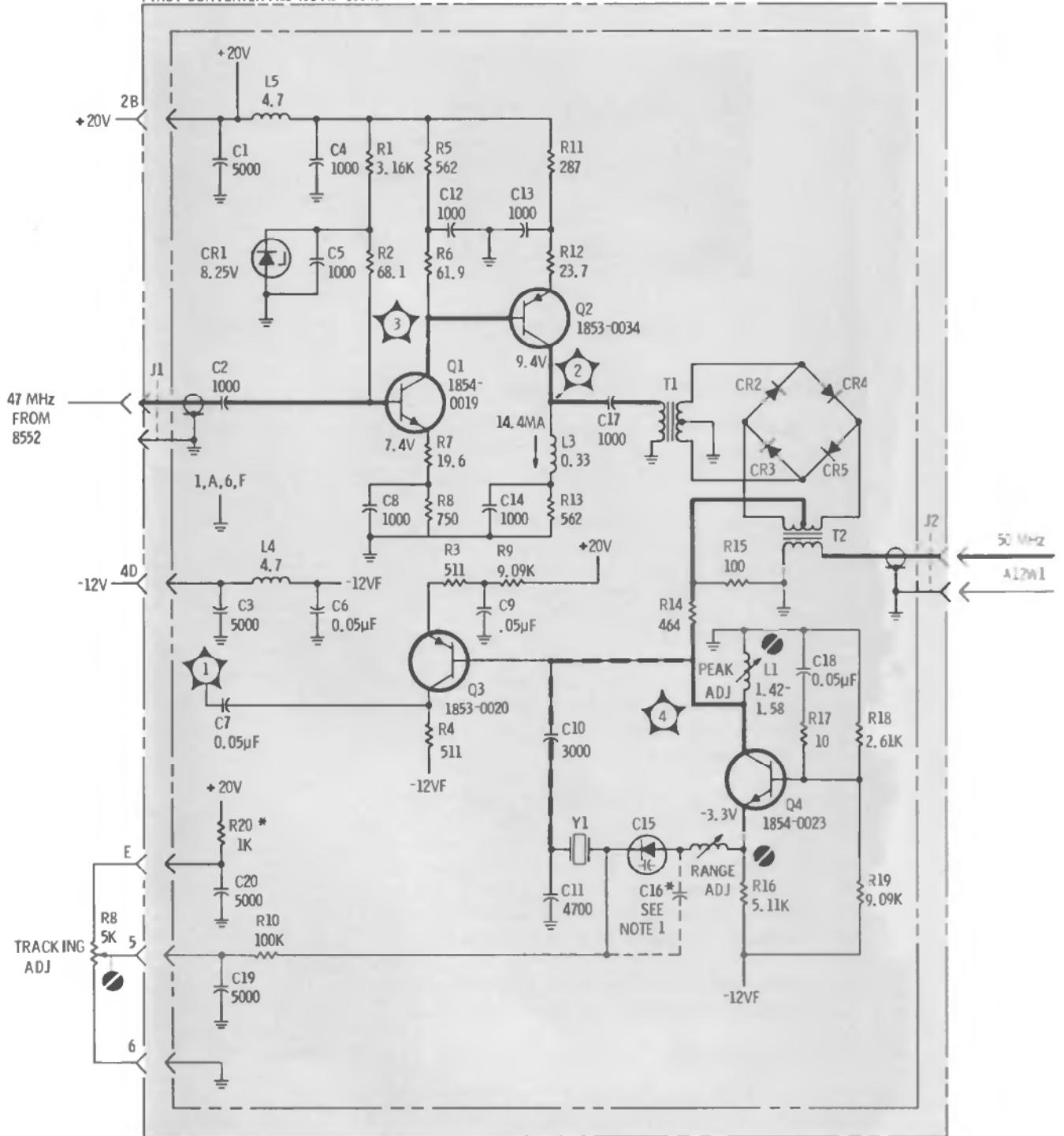

Figure 8-22. A12, 50 MHz Amplifier, Cover and Components



FIRST CONVERTER A13 (08443-60040)



REFERENCE DESIGNATORS

A13	A12	A12A1	A11	CHASSIS
Q1-Q4	Y1	C1-C17	L1-L2	Q1-Q3
L1-L5	Q1-Q2	L1-L2	C1.3-12	L1-L2
R1-R20	R1-R10			R1-R21
T1-T2	L1-L6			CR1-CR5
C1-C18	T1-T2			C1-C11
CR1-CR5				T1-T4
				R8

REFERENCE DESIGNATIONS WITHIN OUTLINED (---) ASSEMBLIES ARE ABBREVIATED. FULL DESIGNATION INCLUDES ASSEMBLY NUMBER. E.G., R1 OF ASSEMBLY A1 IS A1R1. DESIGNATIONS OF OTHER COMPONENTS ARE COMPLETE AS SHOWN.

50 MHz IF AMPLIFIER A12 (08443-60041)

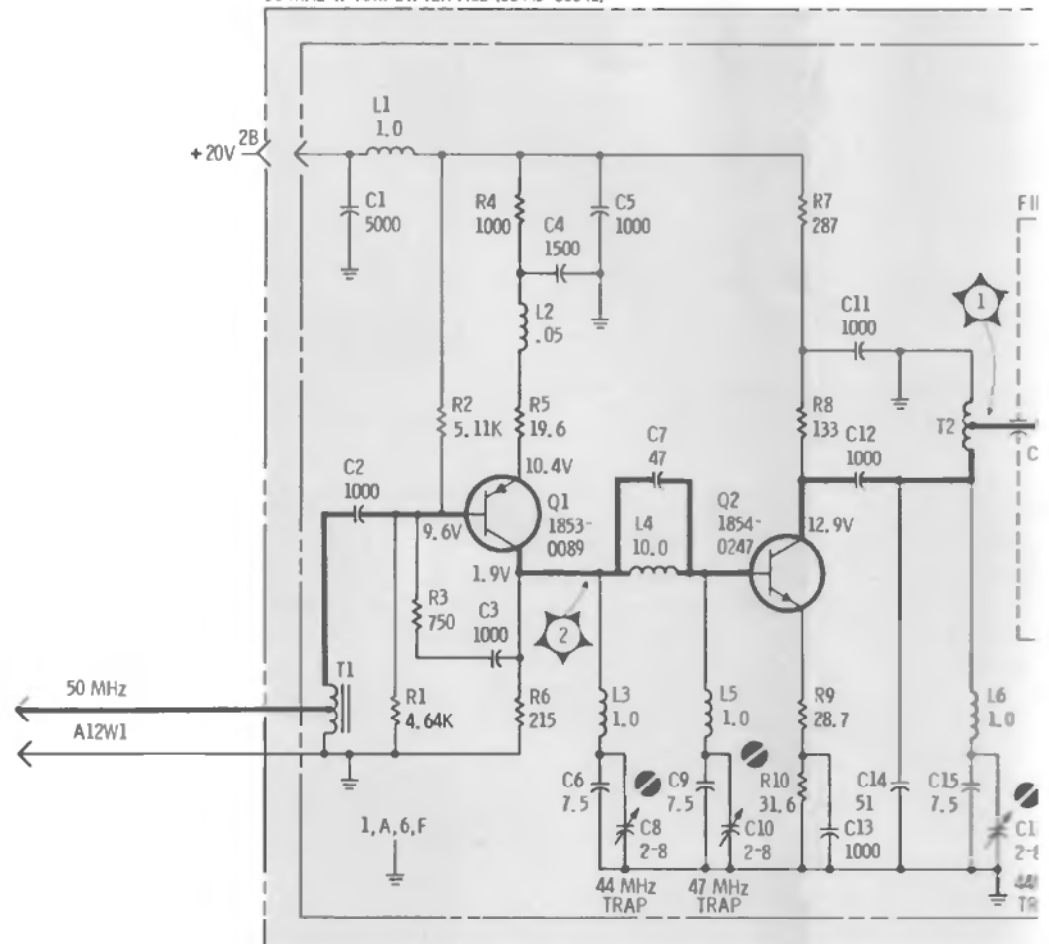

SECOND CONVERTER A11 (08443-60042)

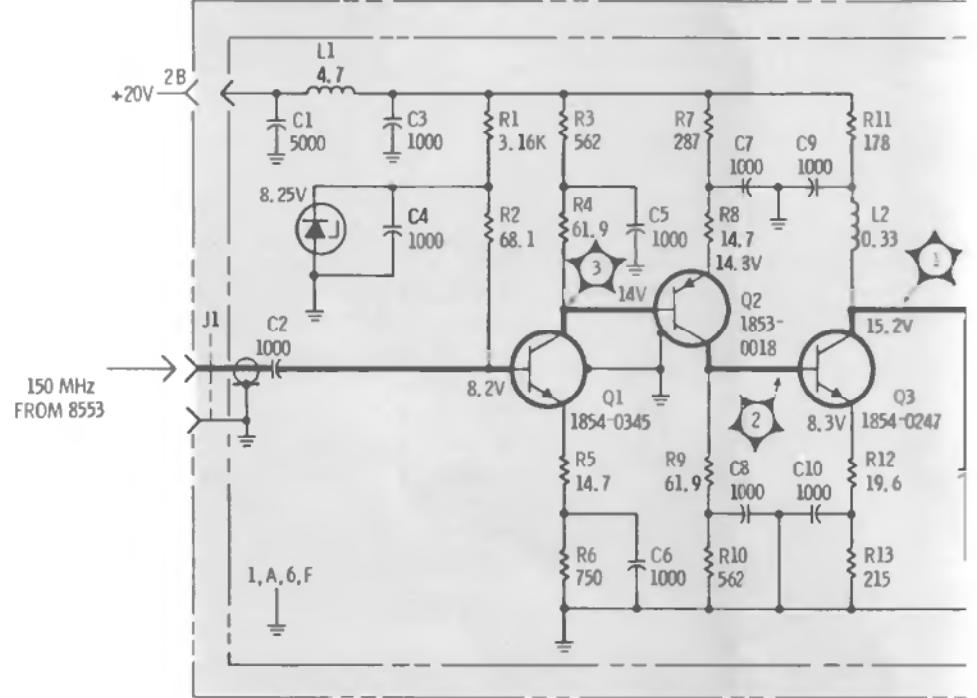

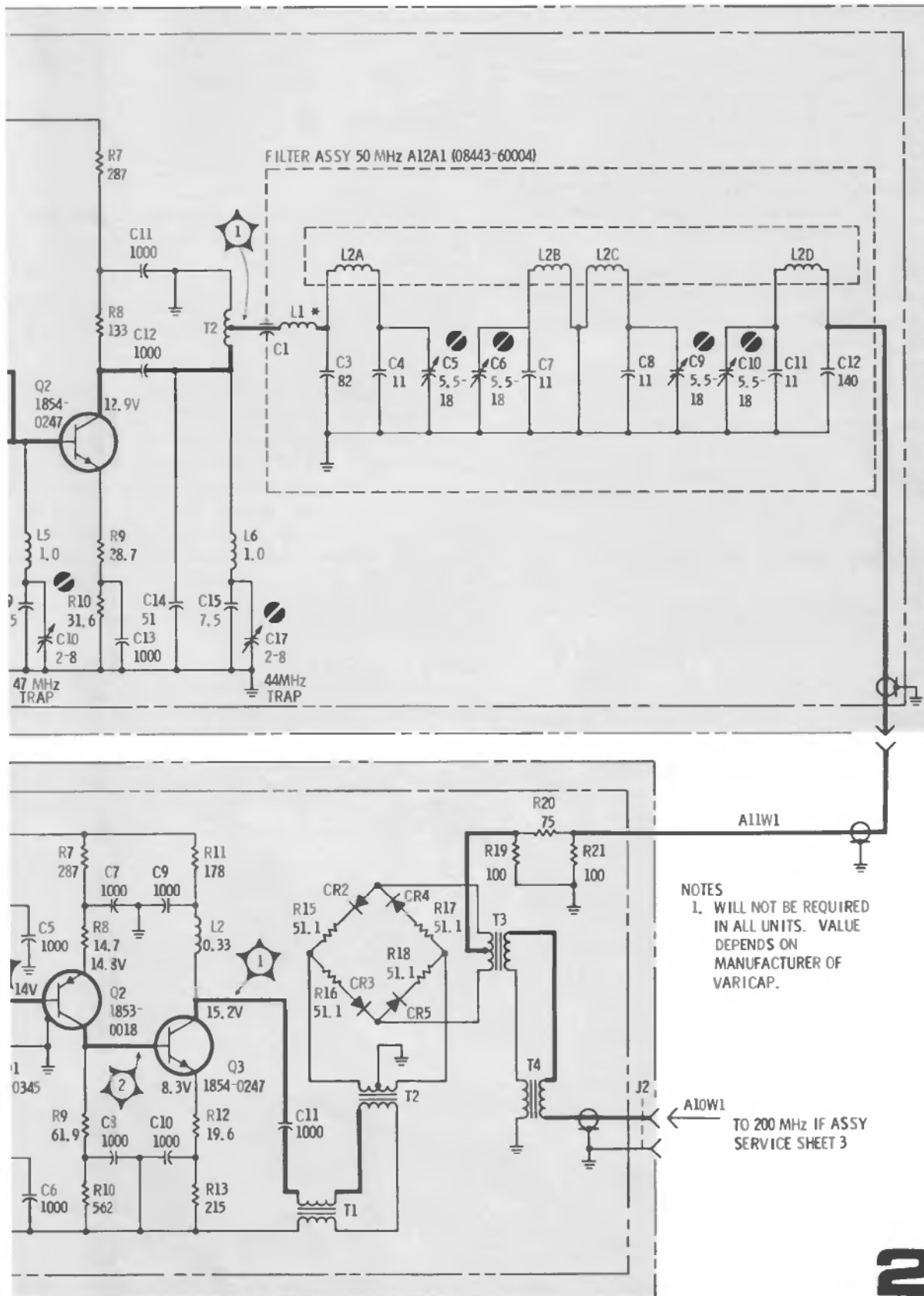

2

Figure 8-23. First and Second Converter and IF Amplifier, Schematic Diagram

Section VIII
Service

SERVICE SHEET 3

Normally, the cause of a malfunction in the model 8443A will be isolated to a circuit board or assembly as a result of performing the tests specified in the Troubleshooting Tree.

When the trouble has been isolated to a specific circuit, the circuit board should be removed and reinstalled using an extender board to provide easy access to test points and components.

All tests are based on the assumption that the model 8443A is interconnected with a HP 8553/8552/140 Spectrum Analyzer which is known to be operating properly.

Equipment Required:

Digital Voltmeter	Service Kit
Shielded Probe	0 – 1250 MHz
Variable Voltage	Spectrum Analyzer
Power Supply	BNC to BNC coaxial Cable

Spectrum Analyzer Control Settings:

POWER	ON
DISPLAY CONTROLS	Set for clear display
SCAN WIDTH PER DIVISION	10 MHz
SCAN WIDTH	PER DIVISION
BANDWIDTH	300 kHz
INPUT ATTENUATION	10 dB
LOG REF LEVEL	0 dBm
SCAN TIME	
PER DIVISION	20 MILLISECONDS
VIDEO FILTER	OFF

Tracking Generator/Counter Control Settings:

POWER	ON
MODE	MARKER
RESOLUTION	ANY
RF OUTPUT LEVEL dBm	All controls set to 0

Note

In individual tests only those controls mentioned need to be changed. Other control settings are compatible with previous tests.

1 200 MHz IF Amplifier A10

The 200 MHz IF amplifier assembly contains a two-stage variable-gain amplifier and a bandpass filter. The gain of the amplifier is controlled by the ALC signal from the Video Amplifier/Automatic Level Control Assembly, A8. L10/C17 is a 250 MHz trap. L2/C3 is a 150 MHz trap. L3/C5 is a 100 MHz trap. The gain of the 200 MHz amplifier is about 20 dB.

The bandwidth of the 200 MHz IF Bandpass Filter is ± 2 MHz. Insertion loss is about 2 dB.

Test Procedure 1

Note

Before proceeding with tests disable the ALC signal by lifting the A8 assembly out of its socket.

Test 1-a. Use the Digital Voltmeter to verify the presence of -12 volts at terminals shown on the schematic diagram.

Test 1-b. Connect the 200 MHz output from the A10 assembly to the RF INPUT of the 0 – 1250 MHz Spectrum Analyzer and tune the CENTER FREQUENCY MHz to 200 MHz. 0 – 1250 Spectrum Analyzer controls are set the same as the 8553/8552 except SCAN WIDTH is set to .5 MHz/Div. Center the signal on the analyzer CRT. The CRT display should be similar to that shown in waveform SS3-1. If the correct display is present, the A10 assembly is functioning properly. If it is not, proceed to test 1-c.

Test 1-c. Connect the input of the bandpass filter (Test Point 2) to the RF INPUT of the 0 – 1250 Spectrum Analyzer. The waveform should be similar to that shown in SS3-1. If the correct waveform is present, but was not present in test 1-b, trouble is probably in the bandpass filter. Repair as required and repeat test 1-b. If the correct display is not present, proceed to test 1-d.

Test 1-d. Connect Test Point 3 (junction of C8/C9) to the RF INPUT of the 0 – 1250 Spectrum Analyzer. The CRT display should be similar to that shown in waveform SS3-2. If the correct display is present, but was not present in test 1-c, check Q2 and associated components. If the display is not present proceed to test 1-e.

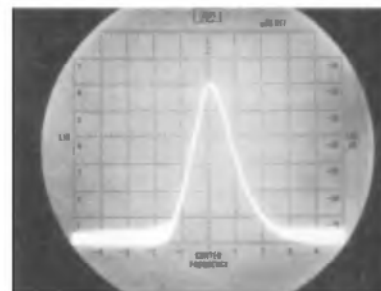

Waveform SS3-1

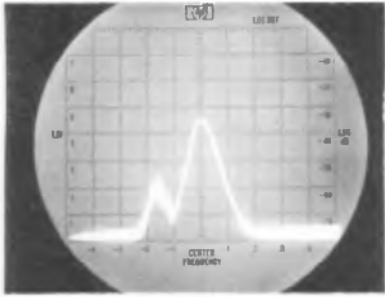

Waveform SS3-2

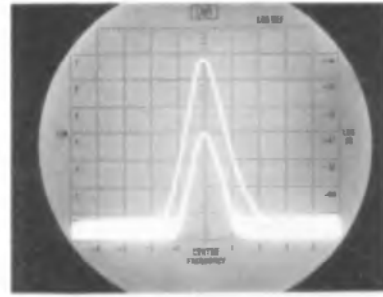

Waveform SS3-4

Test 1-e. Connect Test Point 4 (Q1-b) to the RF INPUT of the 0 – 1250 MHz Spectrum Analyzer. The CRT display should be similar to that shown in waveform SS3-3. If the correct display is present, but was not in test 1-d, check Q1 and associated components. If the display is not present, check the traps for a short and the cabling to the A11 assembly. Proceed to test 1-f.

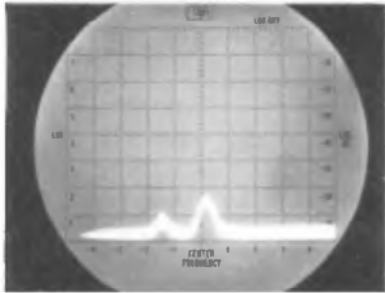

Waveform SS3-3

Test 1-f. Connect the 200 MHz output from the A10 assembly to the RF INPUT of the 0 – 1250 MHz Spectrum Analyzer and tune the CENTER FREQUENCY MHz to 200 MHz. Center the signal on the CRT display. Connect the variable voltage power supply to TP 1 and vary the voltage from 0 to +20 volts. Waveform SS3-4 shows the upper and lower levels of output. The lower level is with +20 volts applied; the higher level is with 0 volts applied. If the signal level does not vary; or if the levels are not approximately as shown, check C1, R4, C8, C9, C10, L6 and adjustment of L6 as specified in paragraph 5-17.

NOTE

After repairing the 200 MHz amplifier assembly it should be adjusted in accordance with paragraph 5-17 of this manual to assure reliable operation of the instrument.

2 Third Converter Assembly A9

The third converter assembly consists of a three-stage, fixed-gain 200 to 310 MHz amplifier, a diode quad balanced mixer and a low pass filter.

The amplifier isolates the model 8443A from the first local oscillator in the analyzer and provides about 20 dB of gain. The bandwidth of the frequencies processed through the amplifier is determined by the position of the SCAN WIDTH switch on the analyzer. When the analyzer is operated at narrow scan width (20 kHz per division or less) in the stabilized mode, the analyzer first local oscillator output is a fixed frequency. (The frequency is still swept, but now by the third local oscillator.)

The diode quad balanced mixer accepts the outputs from the 200 to 310 MHz amplifier and from the 200 MHz amplifier (A10), and mixes them to provide a 0 to 110 MHz signal, or any portion of this range of frequencies. When the analyzer is operated in the ZERO scan mode the output from the mixer is a fixed frequency.

The 120 MHz low-pass filter provides about 75 dB rejection to frequencies above 200 MHz.

Test Procedure 2

Test 2-a. Use the Digital Voltmeter to verify the presence of -12 volts at terminals shown on the schematic diagram.

Test 2-b. Connect the output from the A9 assembly to the RF INPUT of the 8553 analyzer, and set the analyzer frequency to 80 MHz. The analyzer CRT display should be similar to that shown in waveform SS3-5. If the display is as shown, the assembly is functioning properly. If not, proceed to test 2-c.

Test 2-c. Connect Test Point 3 (LO IN to the mixer) to the RF INPUT of the 0 – 1250 MHz

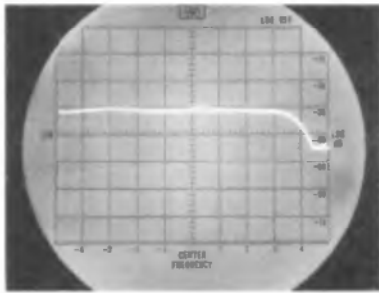

Waveform SS3-5

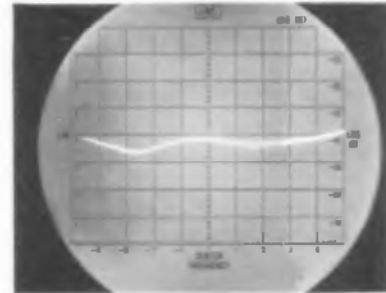

Waveform SS3-7

Spectrum Analyzer and tune to 250 MHz. Controls of both analyzers are set as they were initially except that the 8553/8552 SCAN TIME PER DIVISION is set to .5 MILLISECOND per division and the 0 - 1250 MHz Spectrum Analyzer INPUT ATTEN to -20 dB, LOG REF LEVEL set to 1 on linear scale. The 0 - 1250 MHz CRT should show a display similar to waveform SS3-6. If the display is correct, proceed to test 2-d. If not, proceed to test 2-e.

Test 2-e. Connect Test Point 2 (Q2-c) to the RF INPUT of the 0 - 1250 MHz Spectrum Analyzer, with all controls set as in test 2-c. The CRT display should be similar to that shown in waveform SS3-8. If the display is correct, but was not in test 2-c, check Q1 and associated components. If the display is not present, proceed to test 2-f.

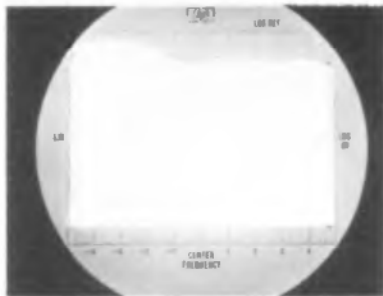

Waveform SS3-6

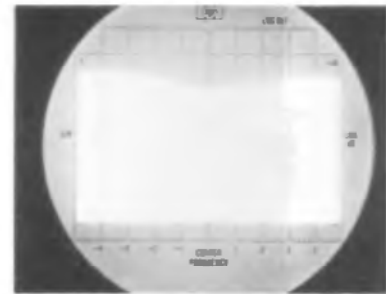

Waveform SS3-8

Test 2-d. Remove the cover from the third mixer and connect the output to the low pass filter to the 8553 RF INPUT. (Be sure to ground the coax shield close to the pickup point.) Set the 8553/8552 SCAN TIME PER DIVISION to 20 MILLISECONDS. The CRT display should be similar to that shown in waveform SS3-7. (It should be noted that with the mixer cover removed, the mixer circuit may be affected by radiation from nearby devices. This may cause the CRT display to differ considerably from that shown. If the CRT display shows that the output frequency goes from 0 to 100 MHz, the test is successfully completed.) If the CRT shows that the output is being swept from 0 to 100 MHz, the low pass filter is probably defective. If the mixer output is not present, repair or replace the mixer and repeat test 2-b.

Test 2-f. Connect Test Point 1 (Q3-c) to the RF INPUT of the 0 - 1250 MHz Spectrum Analyzer, with all controls set as in test 2-c. The CRT display should be similar to that shown in waveform SS3-9. If the display is correct, but was not in test 2-e, check Q2 and associated components. If

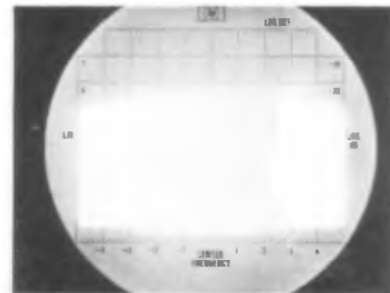

Waveform SS3-9



the display is not present, check Q3, associated components and cabling to the analyzer. After repairs repeat test 2-b.

NOTE

After repairing the third converter assembly it should be adjusted in accordance with paragraph 5-18 of this manual to assure reliable operation of the instrument.

3 Video Amplifier/ALC Assembly (A8) and Attenuators

The Video Amplifier/ALC (automatic level control) contains two amplifiers and a comparator. The input video amplifier provides 32 dB of gain and the second amplifier provides 20 dB of gain.

The comparator is referenced to a fixed level which is controlled by the 0 to 1.2 dB vernier to provide the automatic level control signal to the 200 MHz amplifier.

When the 0 to 1.2 dB vernier is set to 0 the RF output to the 0 to 120 dB attenuator is a constant +10 dBm. The 0 to 1.2 dB vernier may be used to attenuate the RF output linearly from 0 to 1.2 dB.

There are two precision step attenuators connected in series with the RF output. The first is a 0 to 120 dB step attenuator. The second is a 0 to 12 dB, 1 dB per step, attenuator. These attenuators, in conjunction with the 0 to 1.2 dB vernier provide accurate control of the output signal at any level between +10 dBm and -123.6 dBm.

Test Procedure 3

Test 3-a. Use the Digital Voltmeter to check dc input voltages shown on the schematic diagram.

Test 3-b. Connect the Model 8443A RF OUTPUT to the analyzer RF INPUT. A straight line should appear along the LOG REF (top graticule) line on the analyzer CRT. If the correct display is observed, the Tracking Generator portion of the model 8443 is functioning properly. If the CRT display is not correct proceed to test 3-c.

Test 3-c. Connect the 0 – 110 MHz OUT from the A8 assembly to the analyzer RF INPUT and increase the analyzer INPUT ATTENUATION to 20 dB. The analyzer CRT display should be as in test 3-b. If the CRT display is correct, but was not in test 3-b, check the attenuators.

NOTE

Component selection and placement in the attenuators is extremely critical, factory service is recommended.

If the CRT display is incorrect proceed to test 3-d.

Test 3-d. Connect the A8 output to the HF Decade to the analyzer RF INPUT and reset the analyzer INPUT ATTENUATION to 0 dB. The analyzer CRT display should show a straight line across the CRT about -14 dB from the top graticule line. If the display is correct, but was not in test 3-c, U2 is probably defective. After repairs, repeat test 3-b. If the CRT display is not correct, proceed to test 3-e.

Test 3-e. Connect Test Point 1 (R6) to the analyzer RF INPUT. The analyzer CRT display should be similar to waveform SS3-10. If the correct display is observed, but was not in test 3-d, U2 is probably defective. If the display is not correct, U1 is probably defective. Replace and repeat test 3-b. If the assembly is still not functioning properly, proceed to test 3-f.

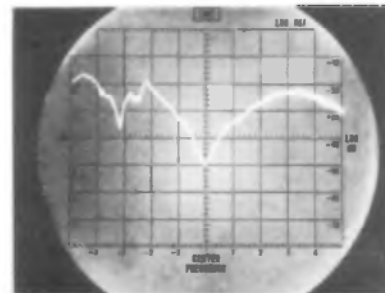

Waveform SS3-10*

Test 3-f. Connect the analyzer RF INPUT to Test Point 2 (Q1A-b). The analyzer CRT display should be similar to waveform SS3-11. If the waveform is not correct, U2 is probably defective. Repair as required and repeat test 3-b. If the waveform is correct and the assembly still does not function properly, proceed to test 3-g.

Test 3-g. Connect the analyzer RF INPUT to TP 3. The analyzer CRT display should be similar to that shown in waveform SS3-12. If the display is incorrect, check Q1, Q2, Q3, Q4 and associated components. After repairs, repeat test 3-b.

NOTE

Component selection and placement in the attenuators is extremely critical, factory service is recommended.

If the CRT display is incorrect proceed to test 3-d.

Test 3-d. Connect the A8 output to the HF Decade to the analyzer RF INPUT and reset the analyzer INPUT ATTENUATION to 0 dB. The analyzer CRT display should show a straight line across the CRT about -14 dB from the top graticule line. If the display is correct, but was not in test 3-c, U2 is probably defective. After repairs, repeat test 3-b. If the CRT display is not correct, proceed to test 3-e.

Test 3-e. Connect Test Point 1 (R6) to the analyzer RF INPUT. The analyzer CRT display should be similar to waveform SS3-10. If the correct display is observed, but was not in test 3-d, U2 is probably defective. If the display is not correct, U1 is probably defective. Replace and repeat test 3-b. If the assembly is still not functioning properly, proceed to test 3-f.

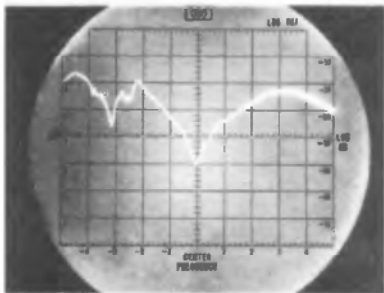

Waveform SS3-10*

Test 3-f. Connect the analyzer RF INPUT to Test Point 2 (Q1A-b). The analyzer CRT display should be similar to waveform SS3-11. If the waveform is not correct, U2 is probably defective. Repair as required and repeat test 3-b. If the waveform is correct and the assembly still does not function properly, proceed to test 3-g.

Test 3-g. Connect the analyzer RF INPUT to TP 3. The analyzer CRT display should be similar to that shown in waveform SS3-12. If the display is incorrect, check Q1, Q2, Q3, Q4 and associated components. After repairs, repeat test 3-b.

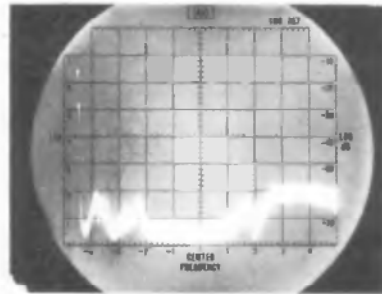

Waveform SS3-11*

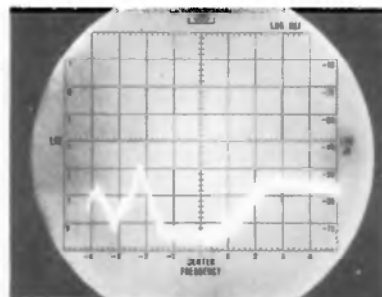

Waveform SS3-12*

NOTE

After repairs the Video Amplifier/ALC assembly should be adjusted in accordance with paragraph 5-19 to assure reliable operation of the instrument.

*These waveforms are typical and may vary greatly between instruments.

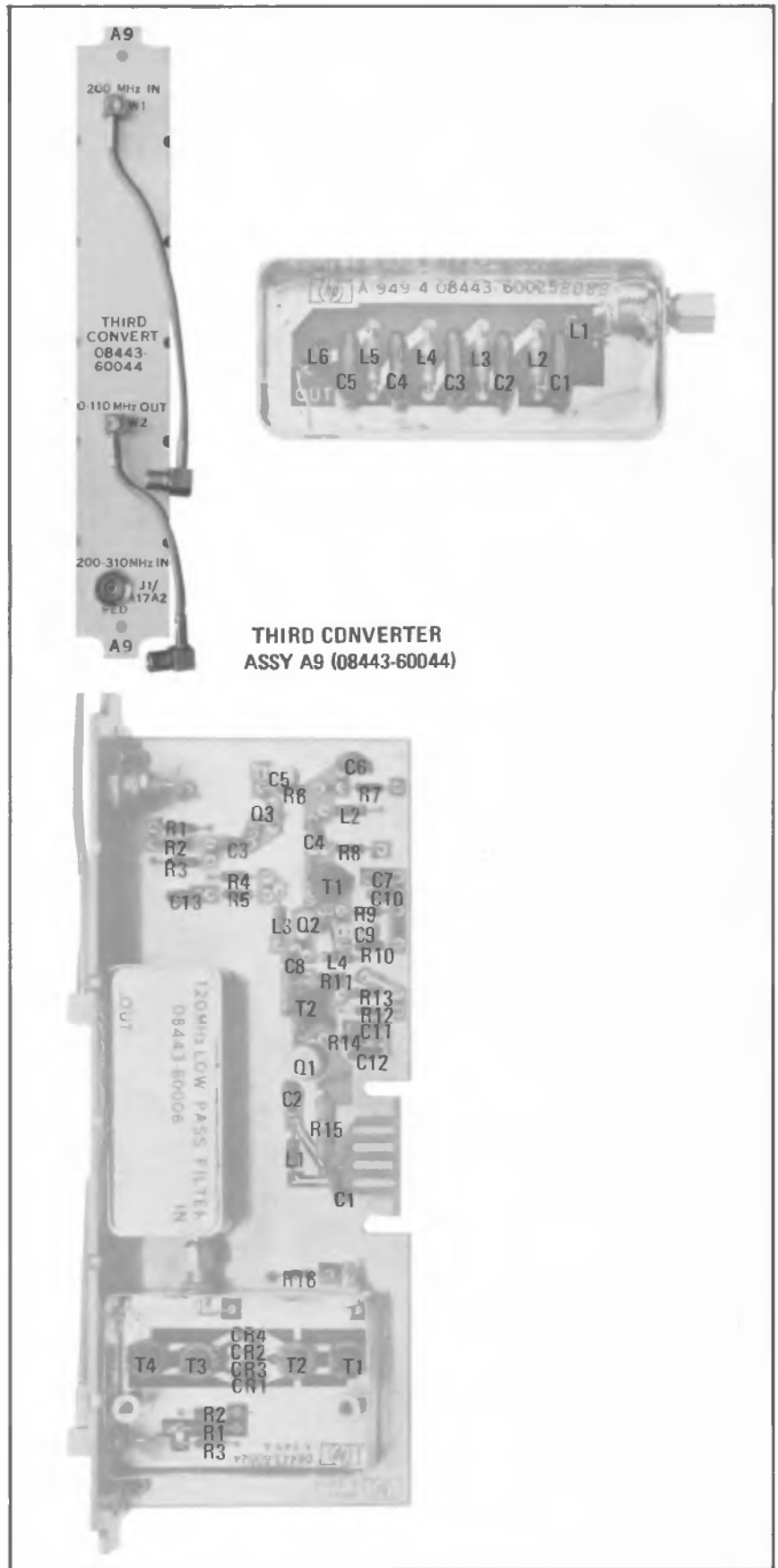
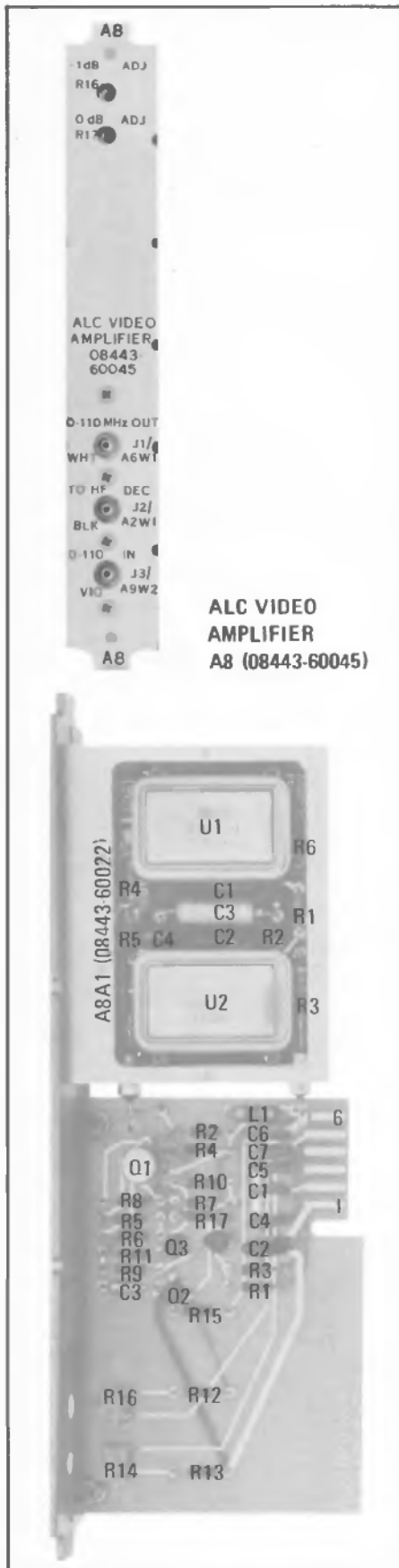
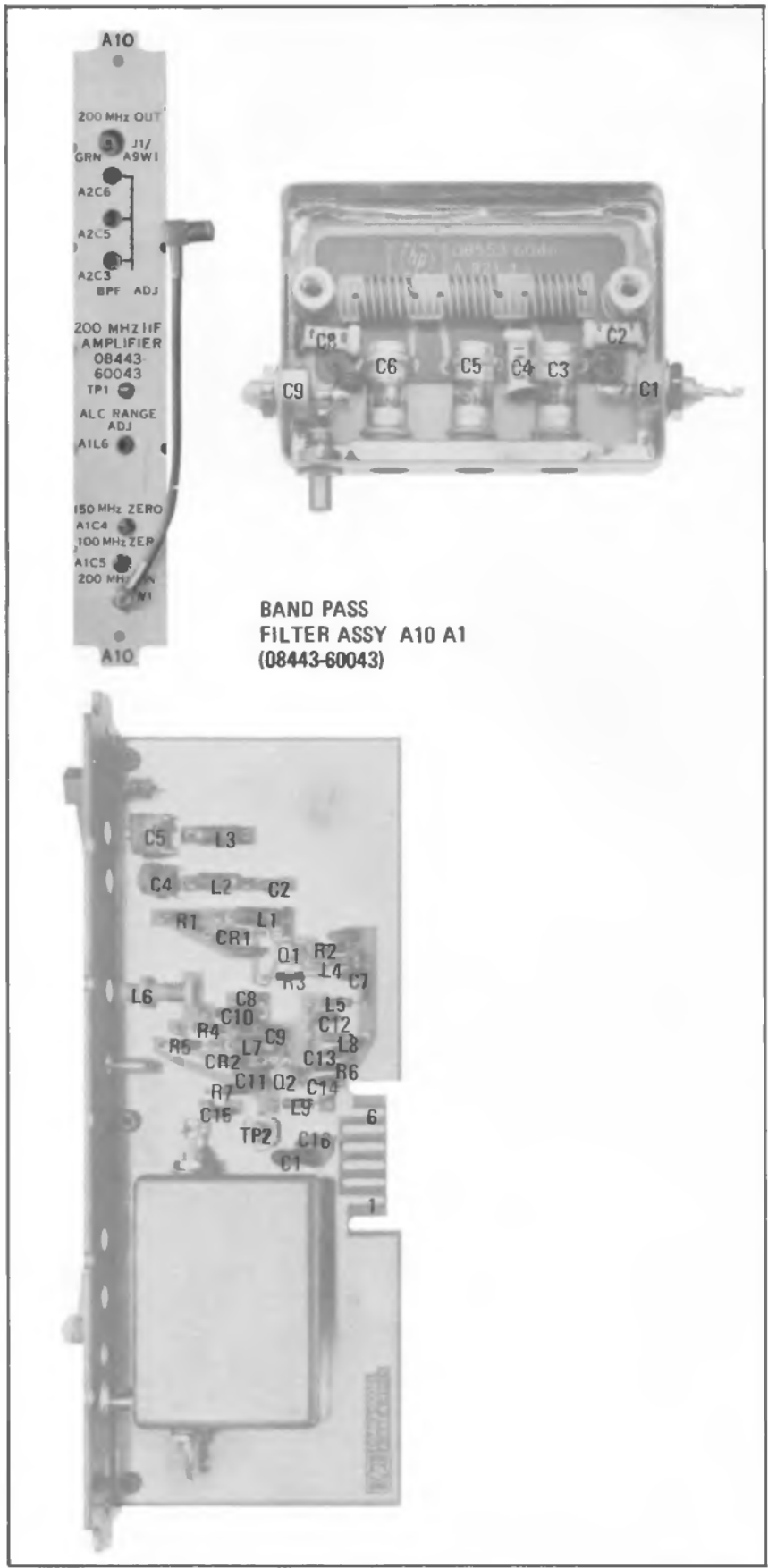

Figure 8-24. A8, ALC Video Amplifier

Figure 8-25. A9, Third Converter Assembly



**BAND PASS
FILTER ASSY A10 A1
(08443-60043)**

Figure 8-26. A10, Bandpass Filter Assembly

200 MHz IF ASSY A10 (08443-60043)

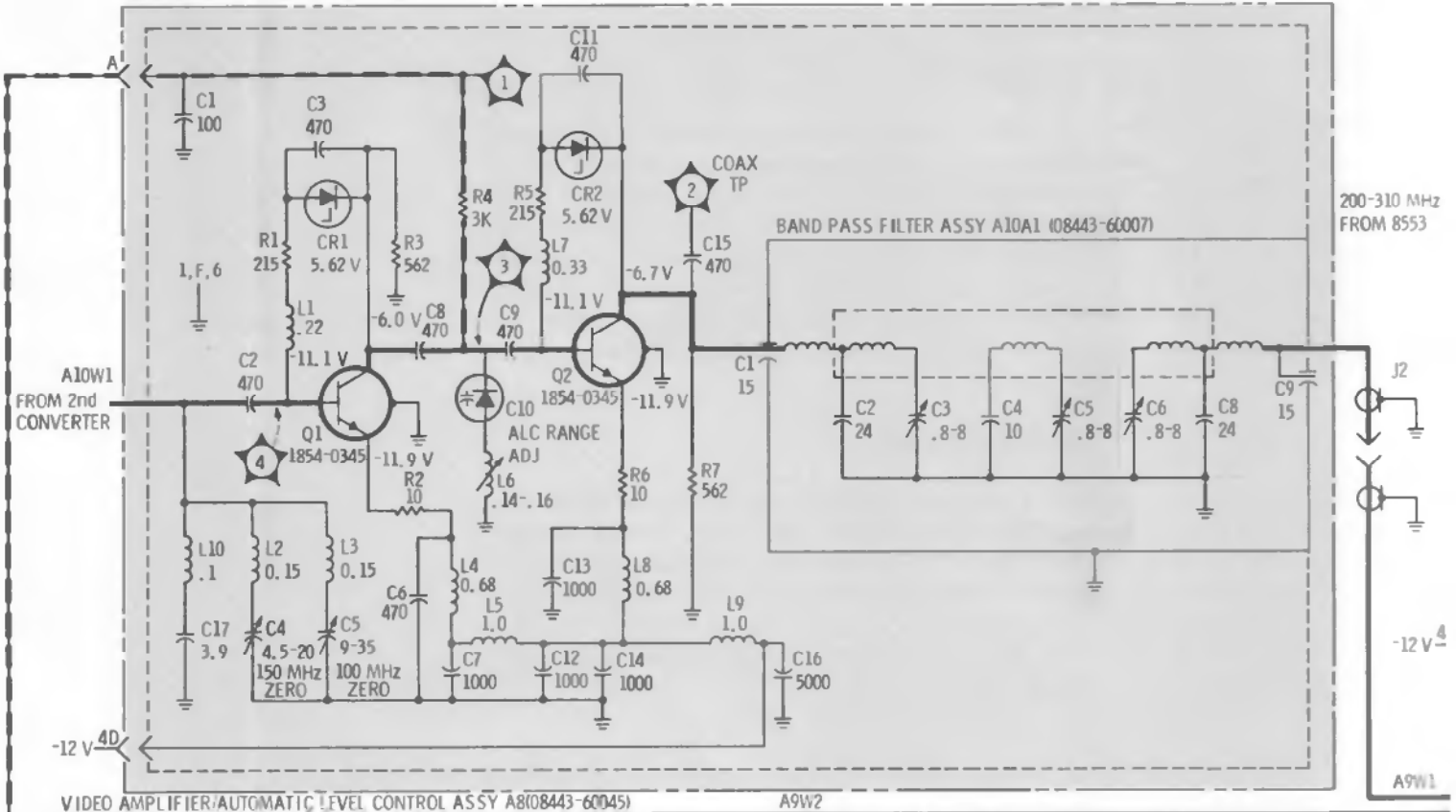

VIDEO AMPLIFIER/AUTOMATIC LEVEL CONTROL ASSY A8(08443-60045)

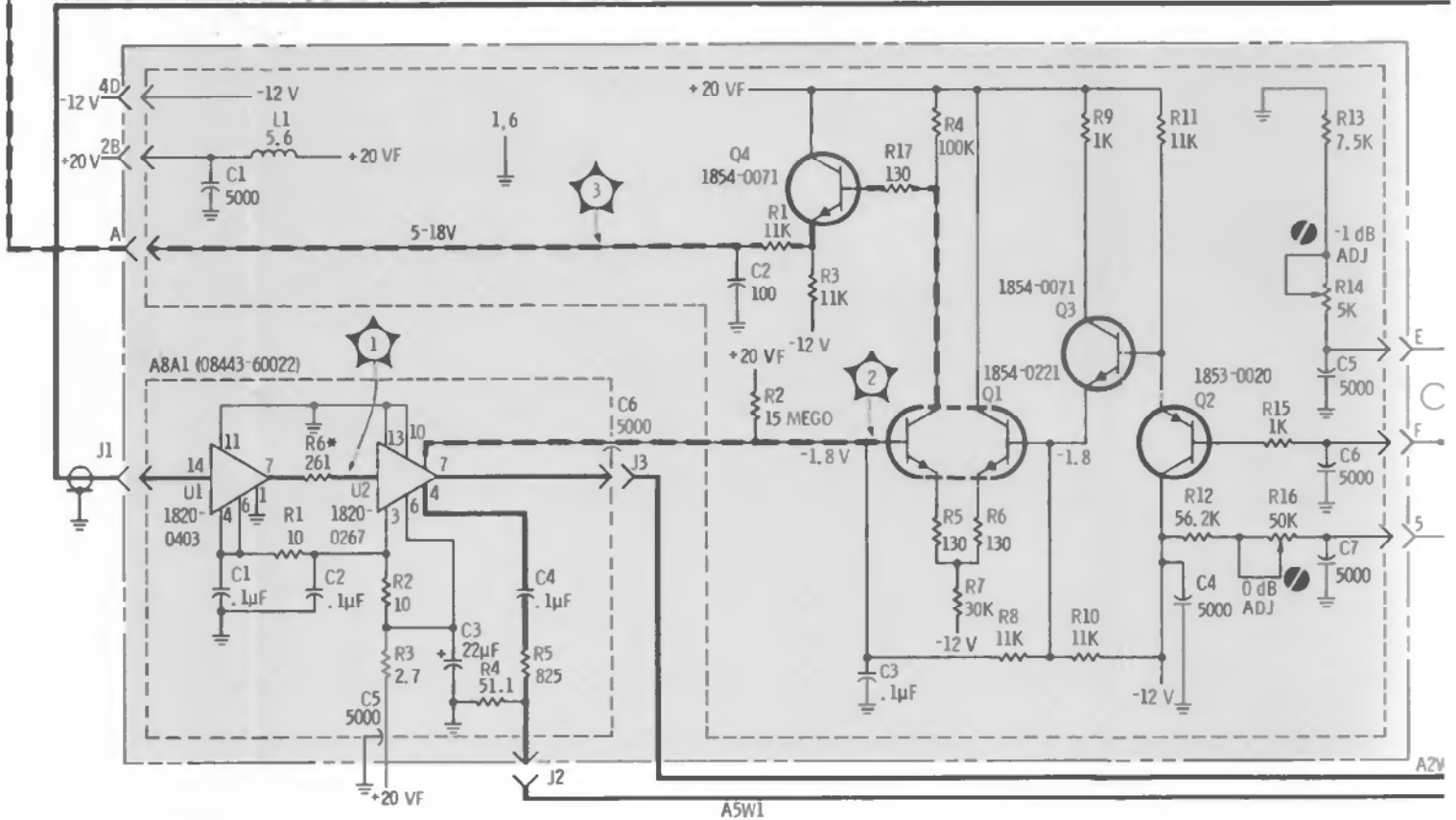

THIRD CONVERTER ASSY A9 (08443-60044)

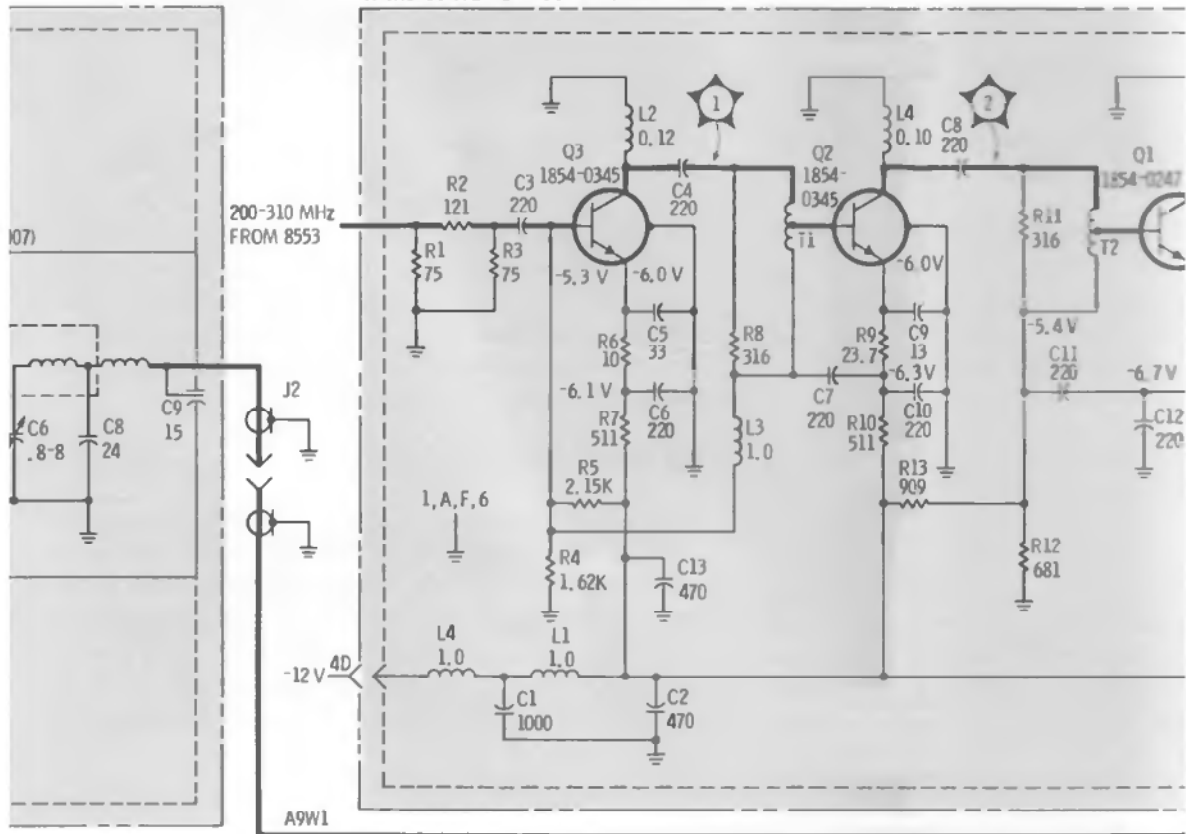

0-120 dB ATTENUATOR ASSY A2 (08443-60001)

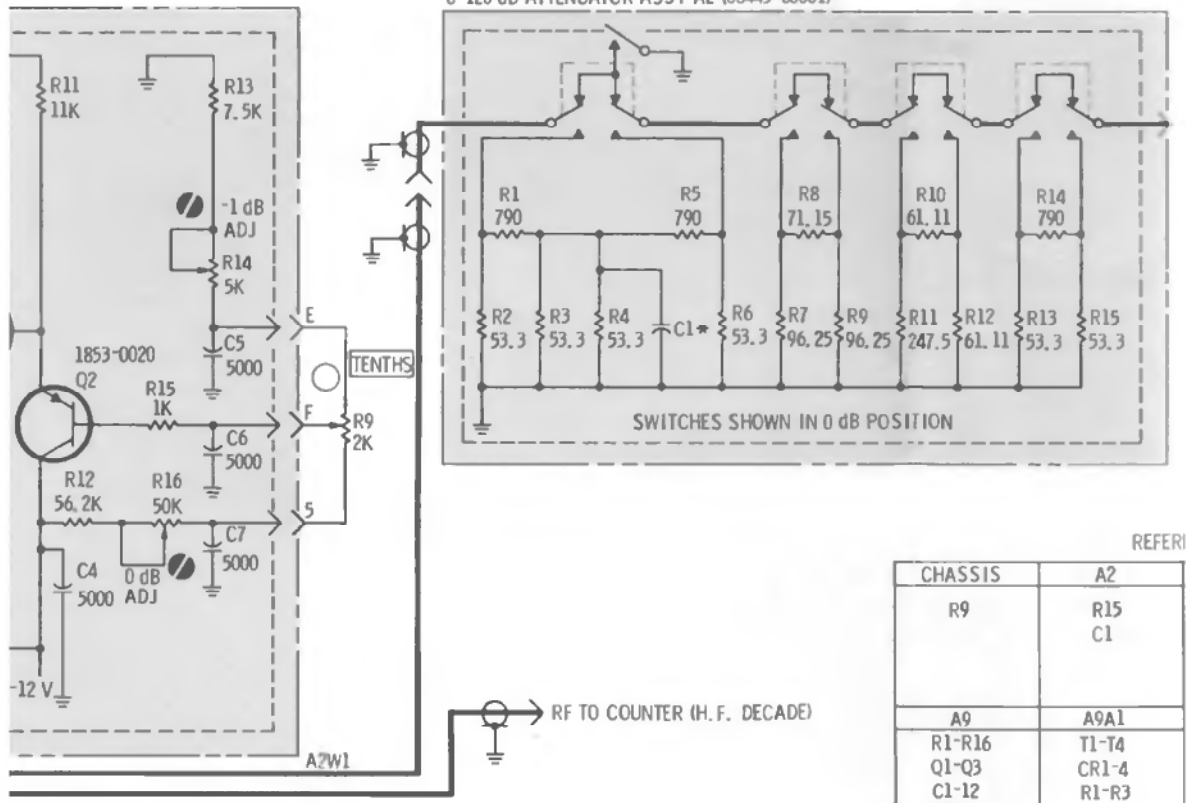

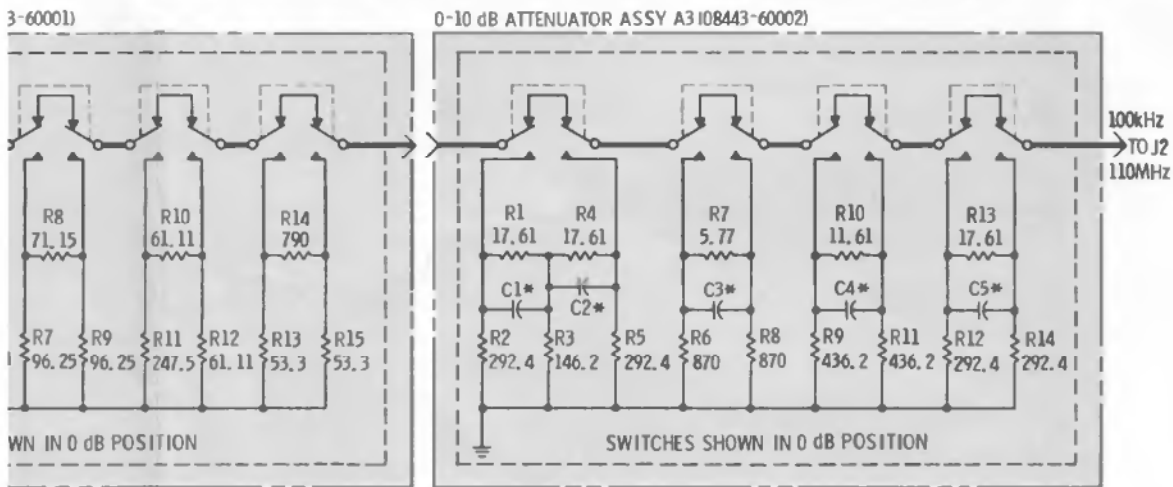
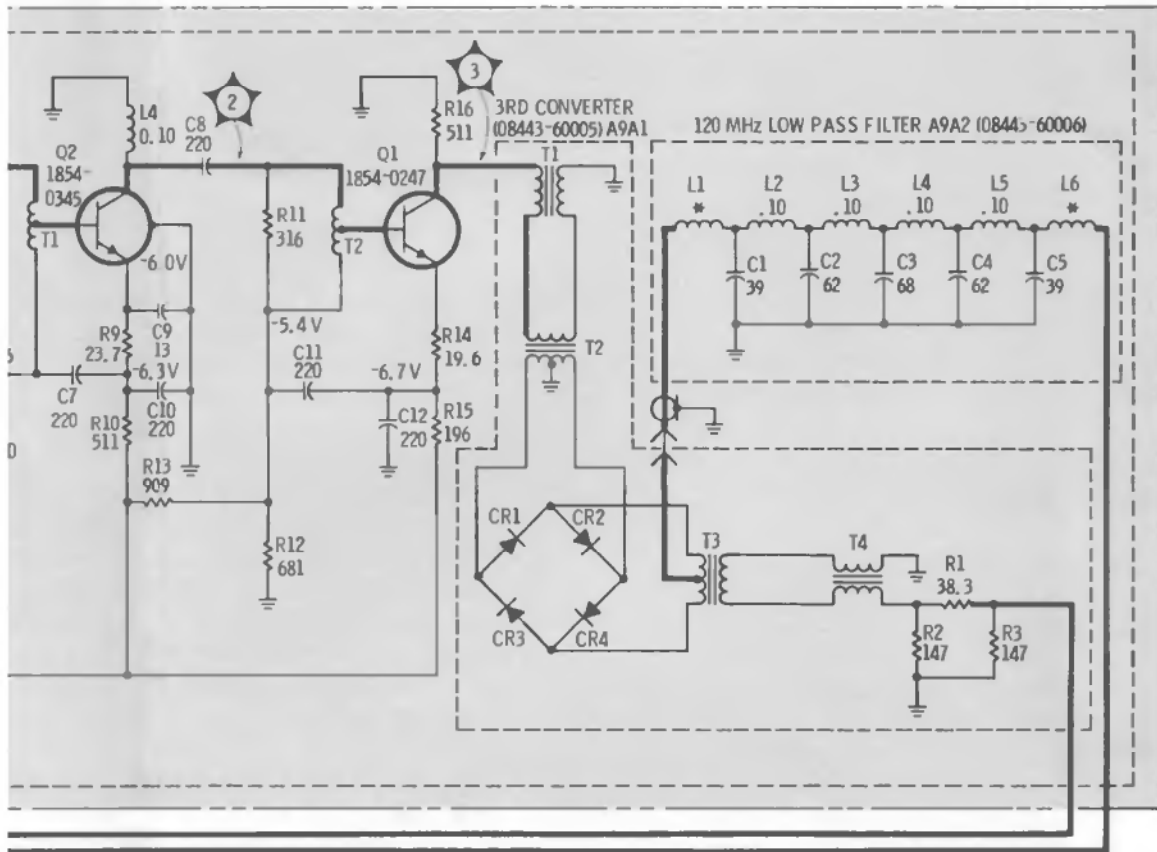

REFERENCE DESIGNATIONS

CHASSIS	A2	A3	A8	A8A1
R9	R15 C1	R14 C5	R1-17 C1-C7 Q1-Q4 L1	U1, U2 R1-R6 C1-C6
A9	A9A1	A9A2	A10	A10A1
R1-R16 Q1-Q3 C1-C12 L1-L4 T1, T2	T1-T4 CR1-4 R1-R3	L1-L6 C1-C5	C1-C16 R1-R7 L1-L9 Q1, Q2 CR1, CR2	L1 C1-C9

CADET

3

Figure 8-27. 200 MHz IF Amplifier, Third Converter, ALC/Video Amplifier and Attenuator, Schematic Diagram

Section VIII Service

SERVICE SHEET 4

Normally, the cause of a malfunction in the model 8443A will be isolated to a circuit board or assembly as a result of performing the tests specified in the Troubleshooting Tree.

Equipment Required

Digital Voltmeter	Spectrum Analyzer
Volt-ohm-ammeter	AC Voltmeter
Service Kit	

1 Rectifier Assembly A14

AC power for the four rectifier circuits in the model 8443A is supplied by a single transformer with four secondary windings.

When the model 8443A is in the standby mode all of the power supplies except the 24 volt (switched) are disabled. The +175 volt, +20 volt, +5.8 volt and -12 volt supplies are all referenced to the 24 volt supply. Placing the model 8443A in standby removes the +24 volt reference from the sense amplifiers and disables all of the series regulators except the +24 volt regulator. The +24 volts is used in standby to maintain temperature control in the crystal oscillator assembly A4.

A full wave bridge type rectifier is used to provide the +175 volts required to drive the numerical readout devices in the counter section.

The +24 volt and +20 volt outputs are derived from a single full wave rectifier and two regulator circuits.

The +6 volt and -12 volt outputs are provided by separate full wave rectifiers and regulators.

Test Procedure **1**

Test 1-a. Turn the model 8443A on and before removing the circuit board, check the voltage levels at the upper end of the fuses mounted on the rectifier board. Check fuse(s) where voltage is not present. If new fuses placed in the +24 volt, +20 volt, +5.8 volt or -12 volt supplies burn out, trouble is probably not in the power supply circuit; proceed to test procedure **2**. If correct voltages are not present at the +24 volt, +20 volt, +5.8 volt or -12 volt fuses and the fuses are good, proceed to test 1-b. If the +175 volts is not present at Test Point 6 on the mother board proceed to test 1-d.

Test 1-b. Remove the rectifier board and reconnect it using an extender board.

WARNING

Remove the power cord from the model 8443A before removing the board. Voltages are still present when the instrument is placed in standby.

Use the AC voltmeter to measure the ac voltages across the primary and secondary windings of the transformer. If any of the secondary windings do not have voltage present and the primary voltage is present, the transformer is defective. If the transformer primary voltage is not present check the line fuse, the line switch, the line filter and the line cord. If ac voltage is present at all windings proceed to test 1-c.

Test 1-c. If the ac voltages are present, use the digital voltmeter to check for dc voltages shown on the schematic. Check components associated with the power supply that is not functioning and repair as required. (Do not overlook C1, C2 and C3 on the mother board.) After making repairs if the model 8443A is still not functioning properly, proceed to Test Procedure **2**.

Test 1-d. If the +175 volt supply is not working remove the rectifier board and reinstall it using the extender board. If the 1/4 amp fuse, F1, is not burned out check CR1 through CR4 and associated components. If the fuse is burned out check Q1, Q2, Q3 and associated components. If the cause of the trouble is not found, or if trouble is found and the instrument still does not function properly, proceed to Test Procedure **2**.

2 Series Regulators

The series regulators are all located on a flange mounted on the inside of the rear panel adjacent to a heat sink located on the outer side of the rear panel.

Series regulators function as a variable resistance in series with the power supply and the load. If the regulated output rises, the series regulators conduct less and cause the output to be lowered. If the regulated output drops, the series regulators conduct more and cause the output voltage to rise. The control circuits for these regulators are discussed in **3** Sense Amplifiers.

Test Procedure 2

Since the series regulator connections are difficult to reach when installed, it is recommended that when one is suspected of being defective, it be removed and checked with an ohmmeter. An alternate method is to remove both the rectifier and sense amplifier circuit boards and make measurements from the connectors.

2 Sense Amplifiers A15

The sense amplifier assembly contains circuits to control the operation of the +24 volt, +20 volt, +5.8 volt and -12 volt series regulators. The +175 volt, +20 volt, +5.8 volt and -12 volt sense amplifiers are all referenced to the +24 volt power supply. Only one adjustable component, R50, is required to set the level of all power supplies.

Each of the sense amplifiers contains a comparator circuit. In the comparator the voltage to be controlled is compared to a fixed reference level derived from the +24 volt supply. The output from the comparator controls the conduction of the series regulators. Two crowbar circuits protect the power supplies from damage in the event of an overvoltage. Current limiting provides additional protection.

Test Procedure 2

When a malfunction has been traced to the sense amplifier circuit board, the board should be removed from the frame and reinstalled using an extender board. Checking for the voltages shown on the schematic diagram should enable the technician to quickly isolate the defective component or components.



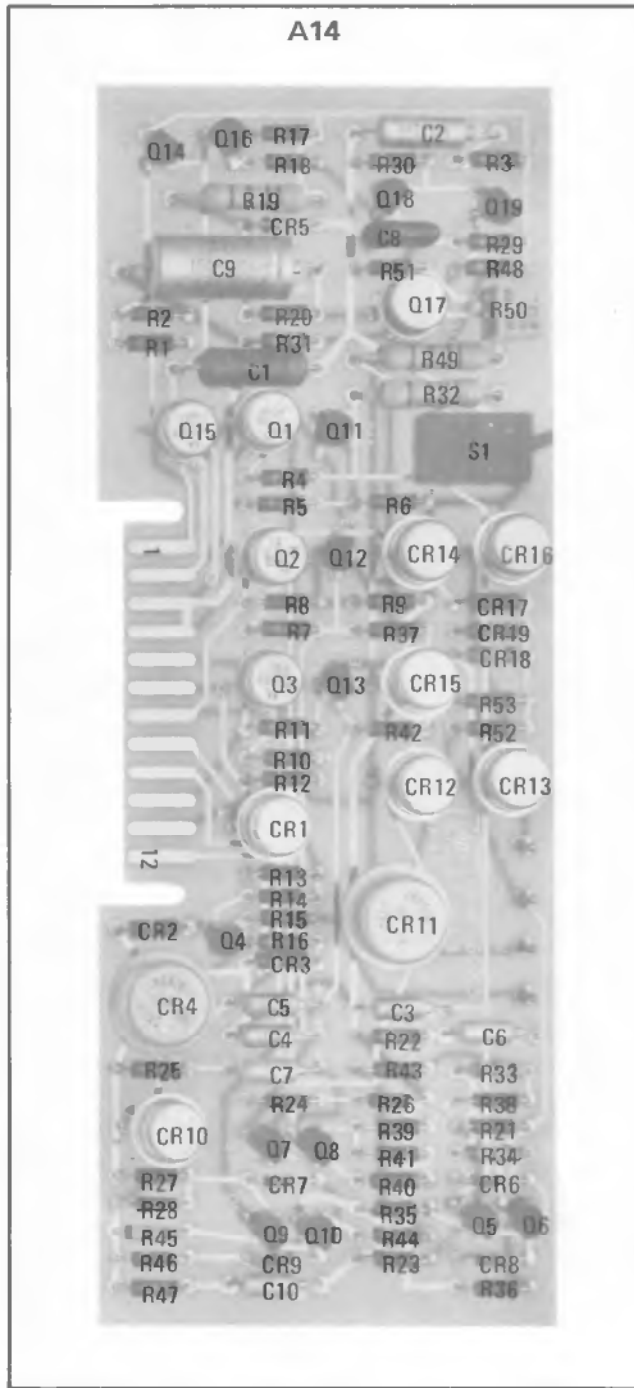

Figure 8-28. A14, Sense Amplifier Assembly, Components

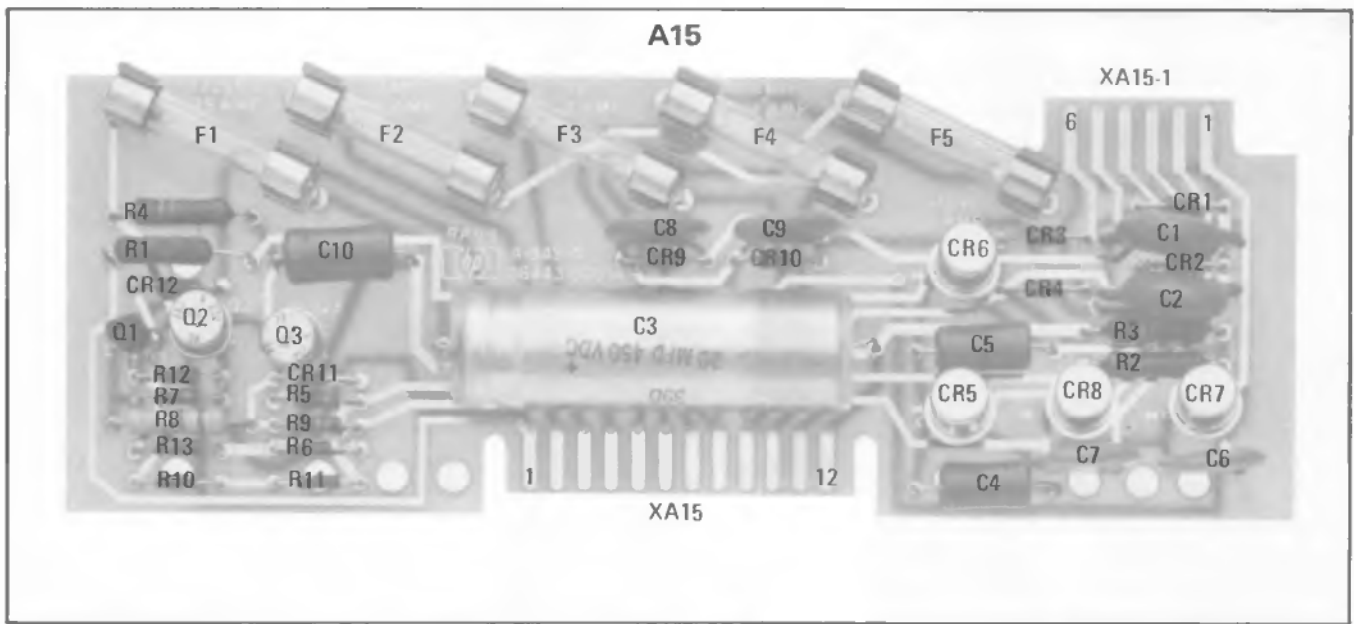
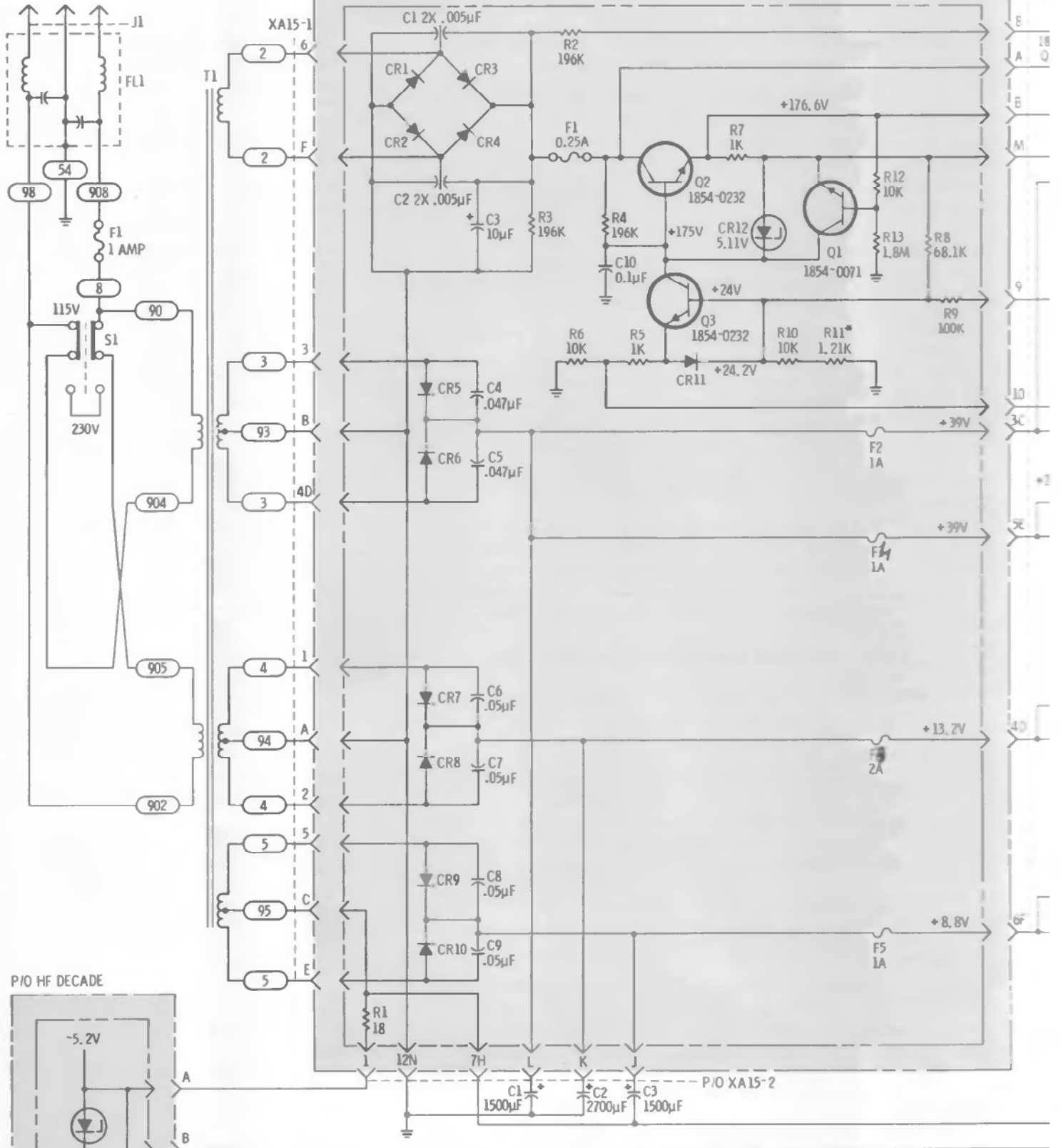

Figure 8-29. A15, Rectifier Assembly, Components

RECTIFIER ASSY A15 (08443-60014)



REFERENCE DESIGNATIONS WITHIN OUTLINED (---) ASSEMBLIES ARE ABBREVIATED. FULL DESIGNATION INCLUDES ASSEMBLY NUMBER, e.g., R1 OF ASSEMBLY A1 IS A1R1. DESIGNATIONS OF OTHER COMPONENTS ARE COMPLETE AS SHOWN.

P/O MOTHER BD ASSY A18 SENSE AMPLIFIER ASSY A14 (08443-6001)

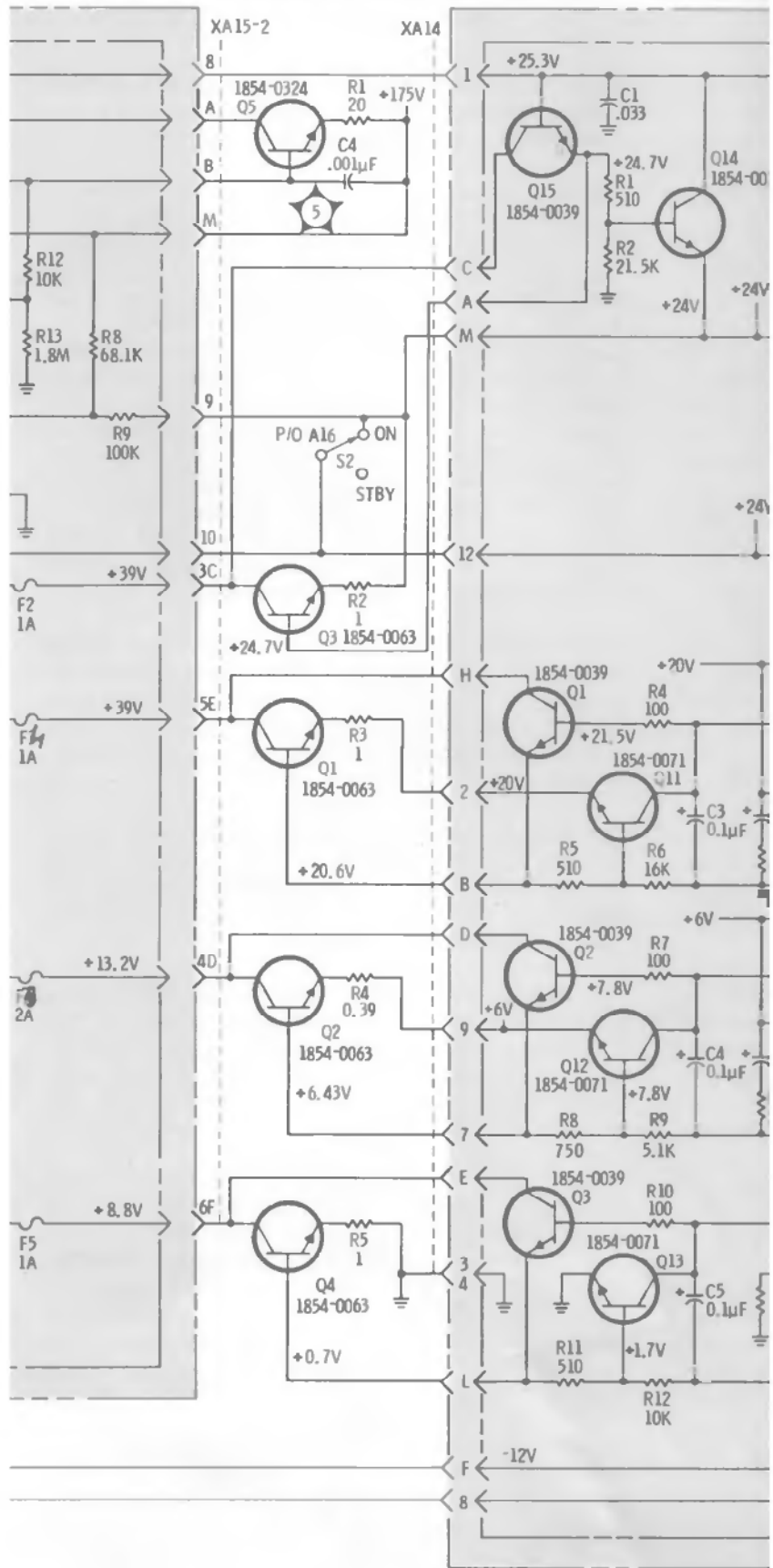

ASSY A14 (08443-60015)

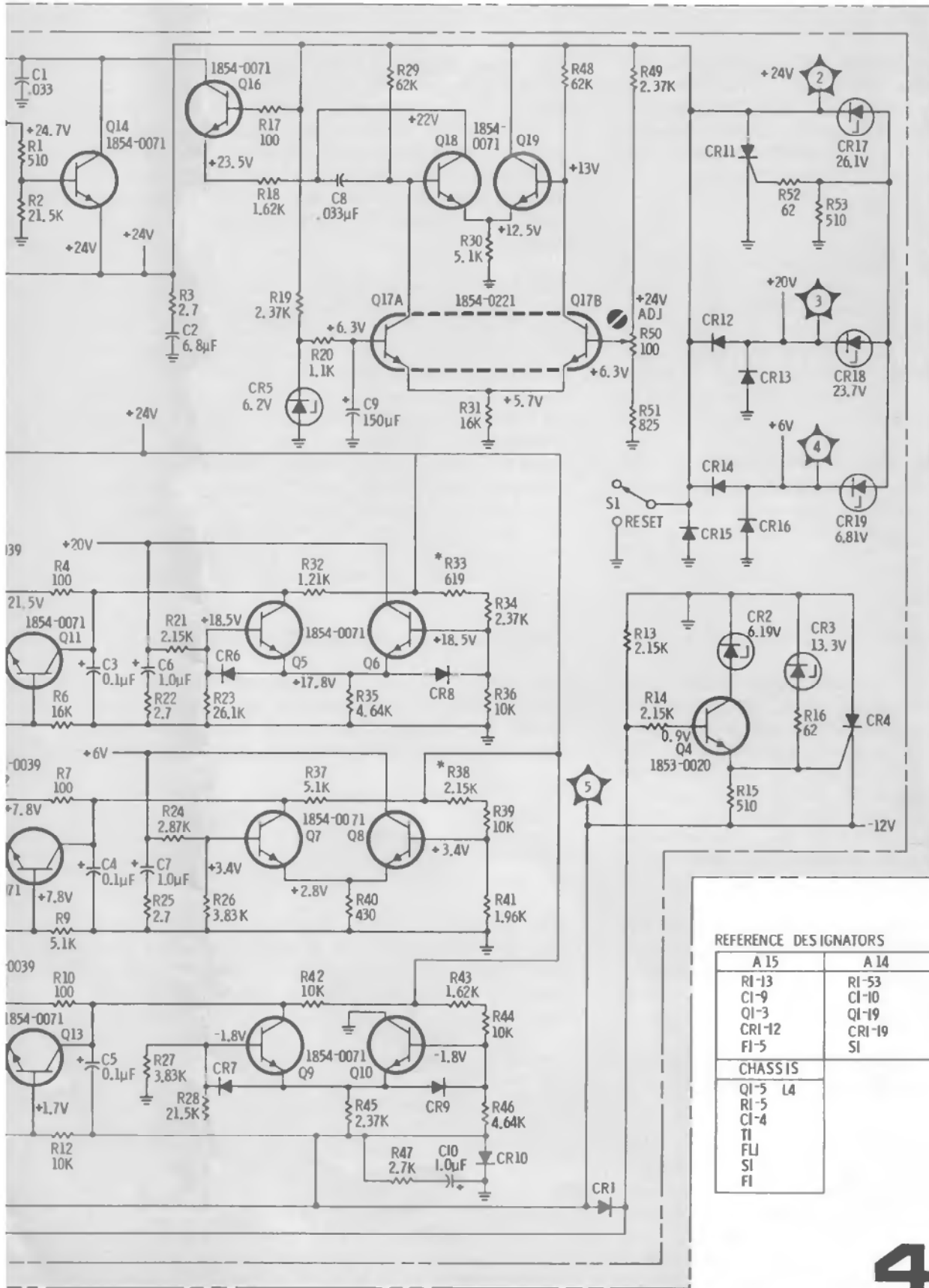

4

Figure 8-30. Power Supplies and Regulators, Schematic Diagram

Section VIII Service

SERVICE SHEET 5

The counter section of the HP Model 8443A consists of five major assemblies. These are the Marker Control assembly A7, the Time Base assembly A5, the High Frequency Decade assembly A6, the Low Frequency Counter assembly A1 and the Reference Oscillator assembly A4.

General

The marker control circuit stops the scan ramp in the model 8552 IF section when the model 8443A is operated in the MARKER and SCAN HOLD modes. The marker control circuit also provides blanking to the analyzer and, when operated in the MARKER or SCAN HOLD modes, a signal to the time base circuit which is used to initiate the count cycle.

When the model 8443A is operated in the MARKER mode the active clamp in the marker control assembly causes the scan ramp of the analyzer to stop at a point determined by the MARKER POSITION control. Usually, the scan is stopped for a period of time determined by the position of the RESOLUTION control. The scan stop period may be extended, for short count periods, by the MARKER INTENSITY control.

When the model 8443A is operated in the SCAN HOLD mode the active clamp in the marker control assembly again causes the scan ramp of the analyzer to stop at a point determined by the MARKER POSITION control. In this mode the scan remains stopped until the mode of operation is changed. The operator can manually position the marker to any point on the scan with the MARKER POSITION control. In the SCAN HOLD mode the counter counts continually.

When the model 8443A is operated in the EXTERNAL mode, the counter section is used to count signals applied to the COUNTER INPUT, J1. The marker control function is not used and the counter counts continually.

When the analyzer is operated in ZERO scan the marker is not used; the counter counts continually.

The time base may be referenced to an internal crystal-controlled oscillator or to an external 1 MHz source. The time base controls the main gate flip-flop, in the high frequency decade, which enables the counter. The time base also generates the transfer and reset pulses. These pulses transfer the information from the decade counters to the numerical readout device drivers and reset the decade counters in both the high frequency decade and the low frequency counter.

The signal is gated to the high frequency decade by the main gate flip-flop which is toggled by the decade divider circuits in the time base assembly. In addition to dividing the input frequency by ten, the high frequency decade provides BCD information to the buffer store in the low frequency counter for the least significant digit and provides the drive for following decade counter stages.

The low frequency counter receives the \bar{A} , \bar{B} , \bar{C} and \bar{D} outputs from the high frequency decade. The \bar{A} , \bar{B} , \bar{C} and \bar{D} outputs are all used to drive the buffer store for the least significant digit. The \bar{D} signal (0 to 11 MHz) also drives the blanking decade counter for the 10^1 readout. The following decade counters are all triggered by the divide-by-ten output of the preceding decade counter. The blanking decade counters drive the numerical readout devices (through buffer store and decoder stages) to provide a visual readout of the input frequency. The buffer store stages also provide BCD information to a rear panel connector for use in equipment external to the model 8443A.

Marker Control Assembly A7 (Service Sheet 6)

The marker control circuit has three inputs from the analyzer IF section. These are the scan ramp input, the blanking input and the ZERO scan input. The analyzer provides a ground reference.

The following paragraphs describe the marker control circuit operation when the model 8443A is operated in the MARKER mode. Differences in circuit operation for other modes of operation are described later in this marker control text.

The scan ramp (a 0 to approximately 8 volt signal) is developed across a capacitor in the spectrum analyzer by current from a constant current source. A comparator in the marker control circuit compares the voltage of the scan ramp to a dc level determined by the position of the MARKER POSITION control. When the charge on the scan ramp capacitor reaches the predetermined level, the comparator acts as an active clamp to sink the current from the analyzer constant current source at a rate that effectively clamps the scan ramp voltage. The analyzer scan is stopped and the output frequency of the model 8443A RF section is counted once.

In addition to the scan ramp and the dc level from the MARKER POSITION control, the active clamp has a control input and a control output. The input is from the \bar{Q} output (TP 4) of the stop-enable flip-flop which allows the active

clamp to operate when the \overline{Q} output is low. The output provides signal information to other circuits that the scan ramp has been stopped.

The stop-enable flip-flop is reset at the beginning of each scan by the end of the blanking pulse (TP 1) from the analyzer. When the analyzer scan ramp ends, TP 1 goes positive until the next scan ramp begins. At the end of the blanking pulse (1), TP6 is low (more about TP 6 later), AND gate (U1A/B/D) output TP 7 goes low and clocks the stop-enable flip-flop. This makes the stop-enable \overline{Q} (TP 4) low and enables the active clamp. However, the active clamp will have no effect on the scan ramp voltage until it reaches the level set by the MARKER POSITION control. When this occurs the spectrum analyzer scan is stopped for a period of time determined by the RESOLUTION control and, in some instances, by the MARKER INTENSITY control.

When the scan ramp is stopped the active clamp stop signal TP8 goes low and causes the output of one-shot C16/R21, TP 10, the count trigger signal, to go low. It also closes a switch on a current sink which is part of the marker intensity circuit.

The marker intensity control circuit controls the intensity of the marker on the analyzer CRT. This is accomplished by providing blanking for long count periods or by extending the scan stop time for short count periods.

The output from Q18 is applied to NAND gate U1C which provides the CLEAR input to the stop-enable flip-flop and to AND gate U1A/B/D which controls the CLOCK input to the stop-enable flip-flop. The signal at TP6 also causes the analyzer CRT to be blanked as determined by the marker intensity circuit. Blanking is required to protect the analyzer CRT from excessive intensity (blooming) during long count periods. During short count periods, when it is desired to keep the marker on the analyzer CRT longer than the count period, TP 6 is held low for a period of time determined by the MARKER INTENSITY control and NAND gate U1C is held high. This prevents the stop-enable flip-flop from being cleared.

The period of time the scan is stopped ends when the CLEAR input to the stop-enable flip-flop goes low, the \overline{Q} output goes high and the active clamp is disabled. This occurs only when signals at TP 6 and TP 10 are both high. The signal at TP 6 is high only when the model 8443A is causing the analyzer CRT to be blanked. The signal at TP 10 is the count acknowledge signal

from the time base circuit signalling that the frequency count has been completed.

In the EXTERNAL mode the CLEAR input to the stop-enable flip-flop is held low. This causes the \overline{Q} output (TP 4) to remain high and disable the active clamp. The inverted input to NAND gate Q16/Q17 is also held low and since the input to NAND gate Q16/Q17 is normally high the count trigger, TP 9 is held low. When the count acknowledge, TP 10, is received, one-shot C18/R40 provides a 200 millisecond low to disable NAND gate Q16/17 and inhibit the count trigger (TP 9) for 200 milliseconds.

In the SCAN HOLD mode signals TP 5 and TP 6 will be held low; CLEAR gate U1C cannot reset the stop-enable flip-flop, the active clamp remains active and the counter counts continually. The major difference between the SCAN HOLD mode and the MARKER mode is that in the SCAN HOLD mode the scan remains stopped until the operator changes the mode of operation.

In the ZERO scan mode (initiated when the analyzer is placed in ZERO scan), operation is the same as in the external mode, except that the counter counts the output of the model 8443A instead of an external frequency source.

Time Base Assembly A5 (Service Sheet 7)

The time base circuit controls all timing and control functions of the counter section. The internal reference generator for the timing function is a stable 1 MHz crystal oscillator. The oscillator is enclosed in a temperature controlled assembly to improve stability. The internal reference signal may be used as a reference for other equipment. An external reference signal may be used in lieu of the internal reference if desired.

Operation of the time base circuit with the model 8443A operating in the MARKER mode is described in the following paragraphs.

During the first 200 microseconds after the marker control circuits stop the analyzer scan, the count trigger signal (TP 2) goes low. When the count trigger goes low the signal at TP 7 will go high provided that the input to the inhibit inverter Q4 is low. This initiates the count cycle.

At the beginning of the timing sequence the time base flip-flop \overline{Q} output (TP 4) is high and the \overline{Q} output is low. The signal at TP 8 will also be high and when the signal at TP 7 goes high, the signal at TP 9 will go low. The signal at TP 5 will go high and all decades will be reset. The signal at TP 5 will remain high about 50 microseconds.

The time base flip-flop is cleared about 50 microseconds after TP 9 goes low. This causes the time base flip-flop \bar{Q} output to go high and the Q output (TP 4) to go low. About 1 microsecond after TP 4 goes low TP 8 goes low, TP 9 goes high and TP 5 goes low to end the reset pulse.

The first decade divider in the time base circuit was set to 0 by the reset pulse and the rest of the decade dividers were set to 9. When the time base flip-flop \bar{Q} output goes high NAND gate U1D couples the 1 MHz reference signal to the first of the five decade dividers. After ten cycles the second decade divider will receive an input. Since the last four decade dividers were set to 9, each will reset to 0 with the first input they receive. The reset output of each divider will reset the following decade divider.

Resolution, which in this case is a function of the time the input signal is counted, is controlled by the three-position RESOLUTION switch.

When the RESOLUTION switch is set to 1 kHz, a ground is provided to a control gate in the third decade divider which provides an output to toggle the main gate flip-flop in the high frequency decade. The output signal (TP 6) is, in this case, a square wave with a 1 millisecond period.

When the RESOLUTION switch is set to 100 Hz, a ground is provided to a control gate in the fourth decade divider which provides an output to toggle the main gate flip-flop in the high frequency decade. The output signal TP 6 is, in this case, a square wave with a 10 millisecond period.

When the RESOLUTION switch is set to 10 Hz, a ground is provided to a control gate in the fifth decade divider which provides an output to toggle the main gate flip-flop in the high frequency decade. The output signal TP 6 is, in this case, a square wave with a 100 millisecond period.

The third, fourth and fifth decade divider outputs are wired to perform an OR function. Only one output will be present at any given time; only one control gate is grounded at any given time.

At the end of the count period the main gate flip-flop in the high frequency decade changes state and provides a low to clock the time base flip-flop. When clocked, the time base flip-flop Q output goes low and the \bar{Q} output (TP 4) goes high. NAND gate U1D is inhibited and the reference signal can no longer reach the decade dividers. In addition, the signal at TP 4 triggers a

150 microsecond one-shot which drives TP 10 high and TP 3 low to transfer information stored in the decade counters in the low frequency counter to buffer store stages and then to the decoders which drive the numerical readout devices.

The 1 microsecond delay between the time TP 4 goes high and TP 8 goes high prevents generation of a reset before the transfer (TP 3) begins, in the case where TP 7 is still high. Once initiated, the transfer signal at TP 3 prevents generation of a reset signal by forward biasing a diode to keep TP 7 low for the duration of the transfer pulse.

When the Q output (TP 4) of the time base flip-flop goes high it is also used as a signal to the marker control circuit to permit the spectrum analyzer scan to continue. The time base circuit then becomes dormant until the next count trigger (TP 2) arrives from the marker control circuit.

When the model 8443A is operated in the SCAN HOLD mode the count trigger (TP 2) is held low. Counting periods are separated by the time required for transfer and reset functions.

In the EXTERNAL mode the count trigger (TP 2) is inhibited by a 200 millisecond one-shot in the marker control circuit, which is triggered by the count acknowledge signal at TP 4.

High Frequency Decade A6 (Service Sheet 8)

The main gate flip-flop, which is controlled by the gate toggle from the time base, controls the start and stop of the count period. The count duration is controlled by the RESOLUTION switch.

The input to the high frequency decade may be either the model 8443A Tracking Generator output or any signal within the counter frequency and amplitude range from an external source.

The high frequency decade is a divide-by-ten decade. The input frequency of 100 kHz to 110 MHz is converted to a 0 to 11 MHz signal and applied to the low frequency counter.

The \bar{A} , \bar{B} , \bar{C} and \bar{D} outputs of the high frequency decade directly drive the buffer store in the least significant digit circuit. In addition, the \bar{D} output drives the following blanking decade counter.

Low Frequency Counter A1 (Service Sheet 9)

The least significant digit (10^0) circuit consists of a buffer store, a decoder driver and a numerical readout device. When the transfer pulse occurs the numerical readout device displays the count that remained in the high frequency decade when the count period ended.

The circuits for the next six digits are identical in function and configuration. Each circuit has a blanking decade counter which provides a BCD output to the buffer store and a divide-by-ten output to drive the next blanking decade counter. The buffer store circuits store the count remaining in the decade counters when the count period ended until the next transfer pulse appears. When the transfer pulse appears the buffer stores provide BCD information to the decoder drivers (\bar{A} , \bar{B} , \bar{C} and \bar{D}) and to a rear panel connector (A, B, C and D) for use in external equipment. The decoder driver stages convert the BCD information to an output which drives one of the ten elements in the numerical readout devices. The third, fourth and fifth numerical readout devices (from the right side) have decimal point inputs. The decimal point to be displayed is selected by the RESOLUTION switch.

All leading zeros to the left of the decimal point, which are also to the left of the first significant digit, are blanked.

The eighth display circuit consists of two flip-flops and two amplifiers. It detects and displays an overflow from the previous decades. One of the amplifiers drives the 1 element in the numerical readout device when an overflow is present. The other amplifier provides an overflow BCD output for external use.



Model 8443A

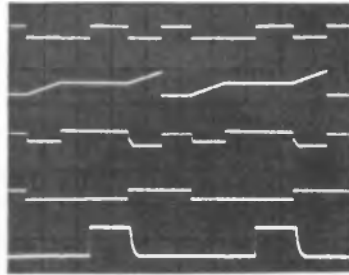

Marker Control

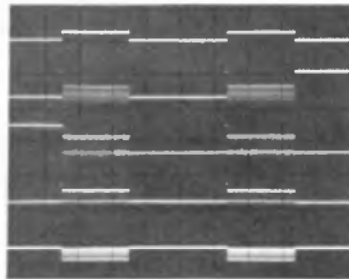

HF Decade

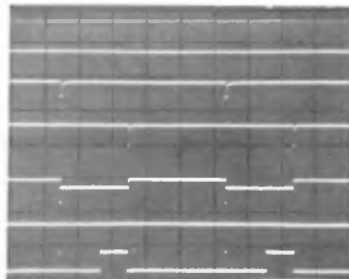

Time Base

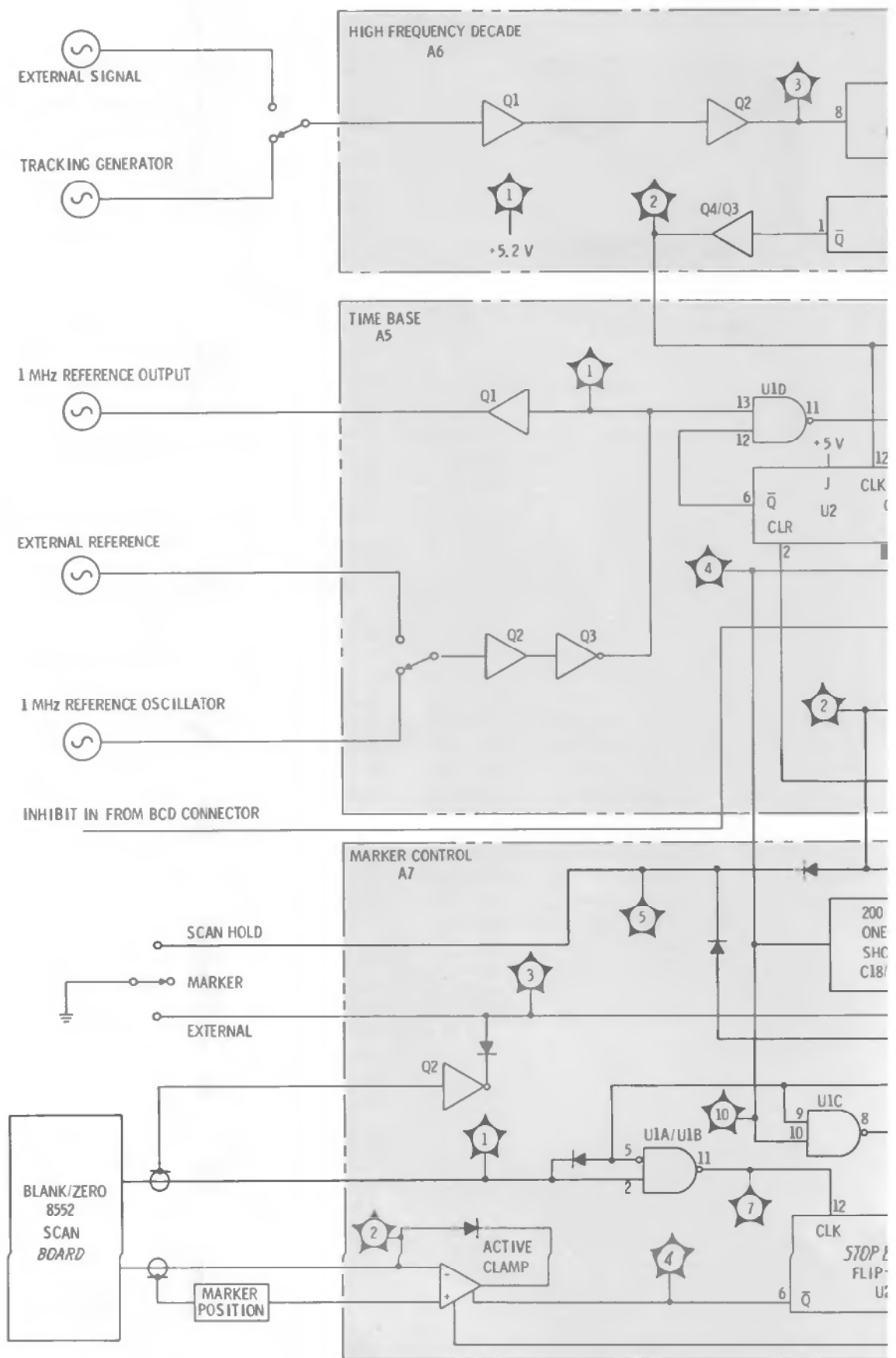

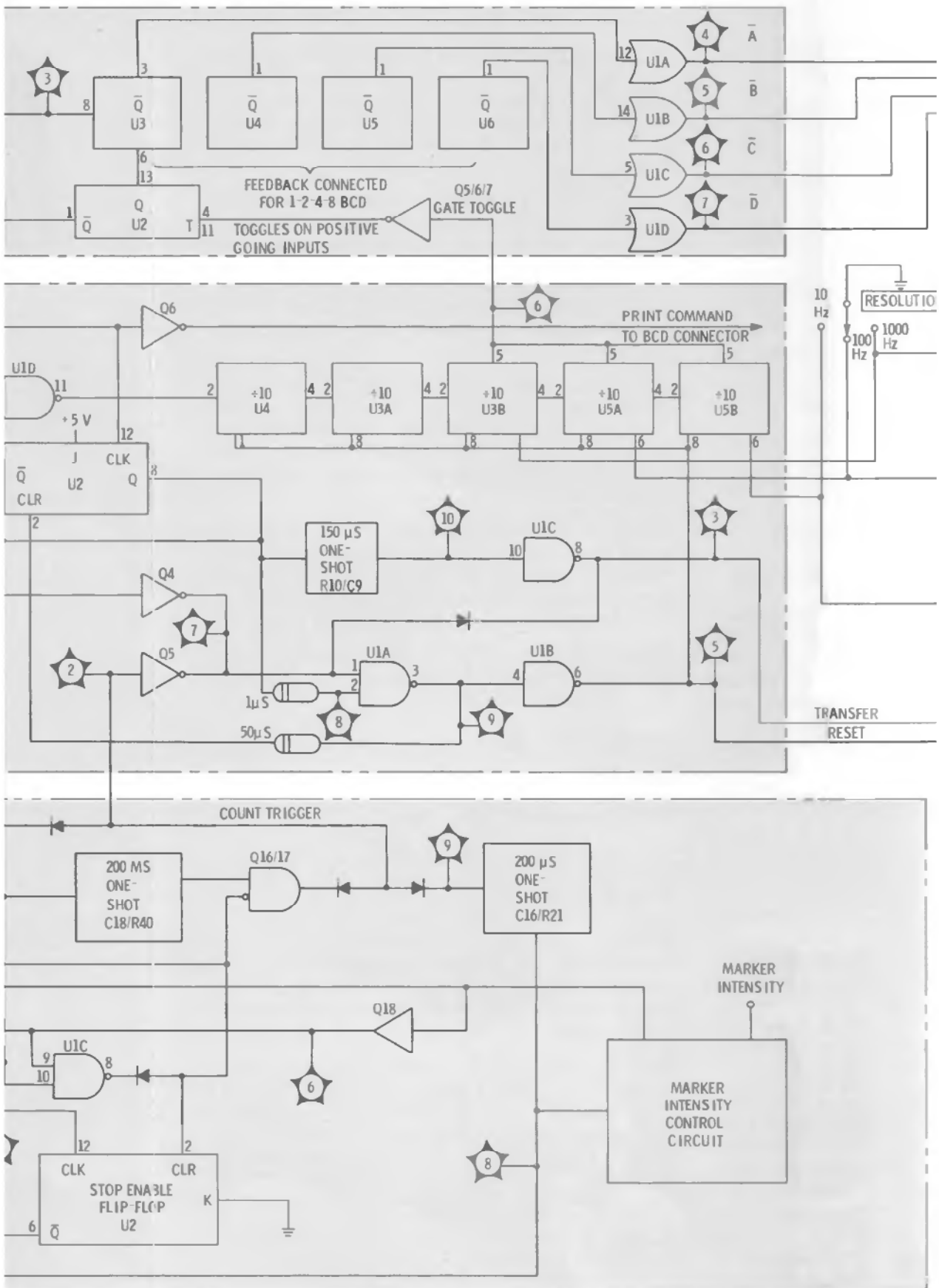

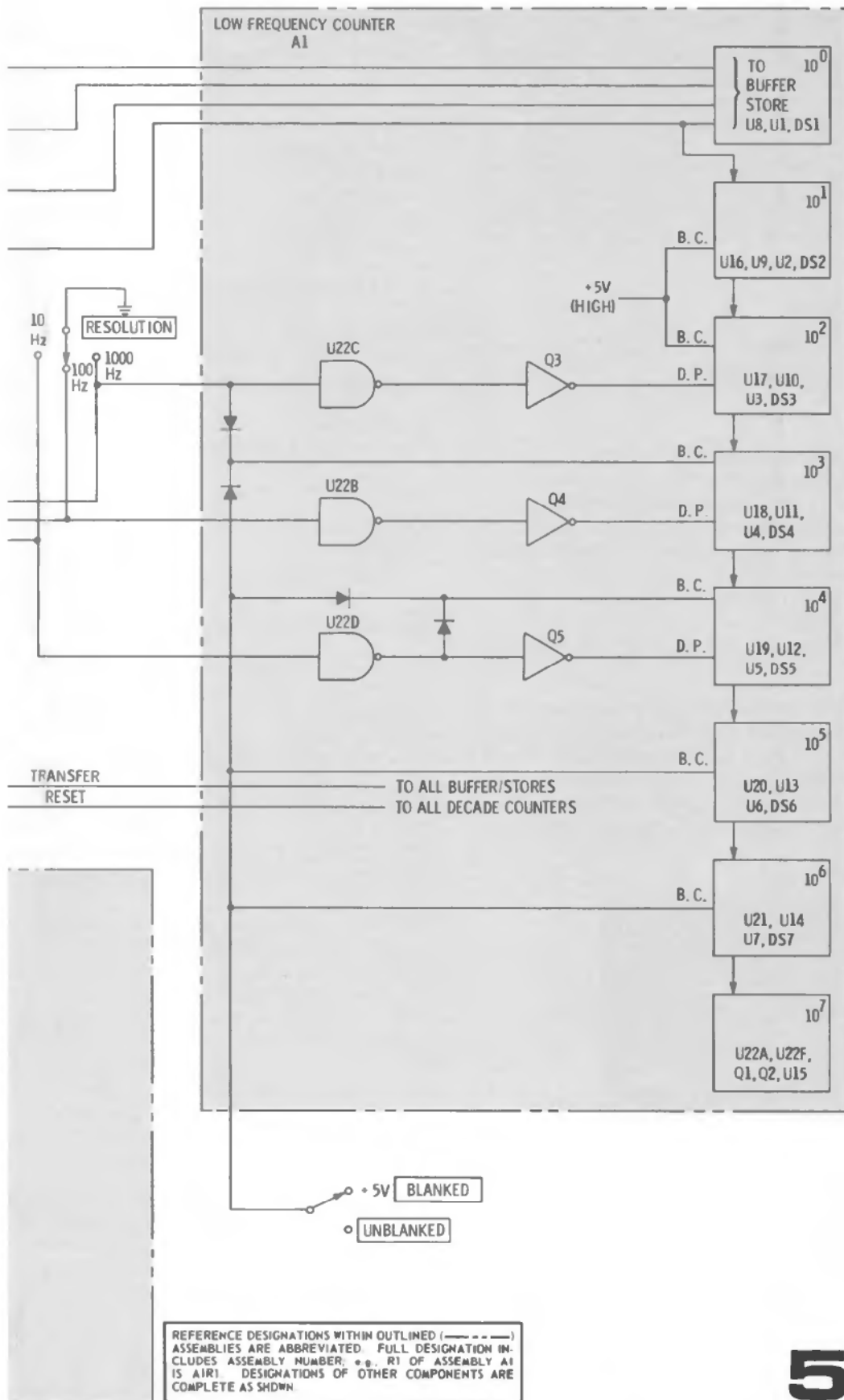

5

Figure 8-31. Counter Section Logic Diagram

SERVICE SHEET 6

Normally, causes of malfunction in the model 8443A circuits will be isolated to a circuit board or assembly as a result of performing the tests specified in the Troubleshooting Tree.

When trouble has been isolated to the marker control assembly (A7), it should be removed from the chassis and reinstalled using an extender board. This will provide easy access to test points and components.

Equipment Required

- 4 Channel Oscilloscope
- 10:1 Oscilloscope Probes (4)
- Digital Voltmeter
- Service Kit

General

The marker control assembly contains circuits which will stop the analyzer scan ramp temporarily, stop the scan ramp for an indefinite period, or enable the counter section to count a simulated signal identical to a signal applied to the analyzer RF INPUT, from an external source. It also contains a circuit which controls the intensity of the marker on the analyzer CRT and a circuit which provides a trigger to start the cycle of the time base circuit.

When the marker control assembly is functioning properly, the waveforms shown in composite waveform SS6-1 will appear at the five test points which are available at the top cover of the assembly. The timing functions of the waveforms shown are identified in the table below the composite waveform.

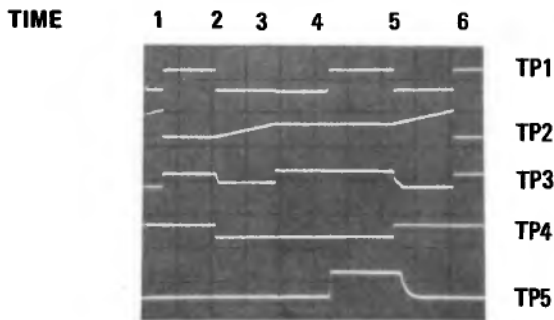

Composite Waveform SS6-1

- Time 1. Analyzer CRT is being blanked by the analyzer scan generator.
- Time 2. Analyzer blanking ends TP 1; Scan ramp starts TP 2; Active clamp is enabled TP 4.
- Time 3. Analyzer scan ramp is stopped TP 2.
- Time 4. Analyzer CRT is blanked by model 8443A TP 1.
- Time 5. Analyzer scan ramp is released TP 2.
- Time 6. Analyzer scan ramp ends TP 2; Analyzer blanking begins TP 1.

Initial Control Settings (for above timing waveforms)

Spectrum Analyzer: (control settings not listed are not important)

- SCAN TIME
- PER DIVISION 1 MILLISECOND
- SCAN MODE INT
- SCAN TRIGGER AUTO

Tracking Generator/Counter

- MODE MARKER
- RESOLUTION 100 Hz
- MARKER INTENSITY Full CW
- MARKER POSITION KNOB Pulled out

Oscilloscope

- Triggered by Analyzer Scan IN/OUT
- TIME/DIV 2 Milliseconds
- VOLTS/DIV 1
- 10:1 probes DC input
- TIME/DIV
- VERNIER set to show one analyzer scan

1 Active Clamp (Instrument in MARKER mode)

The active clamp consists of a comparator (Q5/Q6/Q7) and a current source (Q4/Q8/Q9). The purpose of the active clamp is to stop the analyzer scan ramp at a predetermined voltage level. The reference level for the comparator portion of the active clamp is established by a MARKER POSITION dual potentiometer (R13), a CTR ADJ (center adjust) potentiometer (R11) and a MARKER ADJ potentiometer (A7R11) on the cover of the A7 assembly.

The active clamp is enabled when U2, the stop-enable flip-flop, is clocked by the negative going trailing edge of the analyzer blanking pulse; Q goes low and causes Q20 to conduct, when Q20 conducts, it enables Q9 to provide a path for the current sink and enable the active clamp. Note that Q9 does not actually conduct at this time, it will conduct only when the scan ramp reaches the voltage level predetermined by the MARKER POSITION control. Enabling the active clamp has no immediate effect on the analyzer scan ramp.

The signal input to the comparator is the scan ramp from the analyzer. When the analyzer scan ramp voltage reaches the reference level established by the MARKER POSITION control it is clamped at that level. When the base of Q5A reaches the reference level, Q5B is turned off, Q5B collector goes high and CR2 biases Q4 on to complete the current sink path. The current from the constant current source in the analyzer scan generator circuit is then sunk to the model 8443A -12 volt supply.

Q8, in addition to being in the current sink path, acts as a detector. Since the current from the analyzer scan generator must pass through the emitter-base junction of Q8, Q8 conducts while the scan ramp is stopped and turns on Q1. Q1 will be discussed later in this text.

The analyzer scan ramp is stopped until NAND gate U1C, pins 9 and 10, are high. The input to U1C pin 10 is the count acknowledge signal from the time base circuit which signifies that the count has been completed. The input to U1C pin 9 is generated in the marker intensity circuit. Generation of the signal applied to U1C pin 9 is discussed later in this text.

When both inputs to NAND gate U1C are high the output (pin 8) will go low and clear the stop-enable flip-flop. The \bar{Q} output of U2 then goes high and turns off Q20; Q9 turns off to open the current sink path and the analyzer scan ramp is permitted to continue.

The shield of the scan ramp coax from the analyzer is not grounded in the model 8443A. The shield is used as a ground reference to ensure a common ground between the analyzer scan generator and the active clamp and to prevent ground loops.

CR1 provides protection to Q5 when the connecting cable between the analyzer and the model 8443A is not connected.

Test Procedure 1

Test 1-a. Use the digital voltmeter to verify the presence of dc voltages at terminals 3/C, 4/D and 5/E as shown on the schematic diagram.

Test 1-b. Connect the digital voltmeter between Q5-b and ground; rotate the MARKER POSITION control through its range. The dc level at Q5-b should vary from about ground level (control full ccw) to about +8 volts (control full cw). If observed levels are correct, proceed to test 1-c. If correct levels are not present check Q5B, Q6B, Q7, the MARKER POSITION control and associated components.

Test 1-c. Connect the oscilloscope as follows: Channel A — TP 2, Channel B — Q8-b, Channel C — Q7-c and Channel D — Q9-b. Set all controls as shown for waveform SS6-1 except that the oscilloscope TIME/DIV is 5 Milliseconds and the TIME/DIV VERNIER is in the CAL position (off). The oscilloscope CRT display should be as shown in waveform SS6-2. If the display is as shown, the marker control circuit is functioning properly. If the display is not as shown, proceed to test 1-d.

Test 1-d. With the equipment connected as in test 1-c, ground TP 4. The analyzer scan should stop

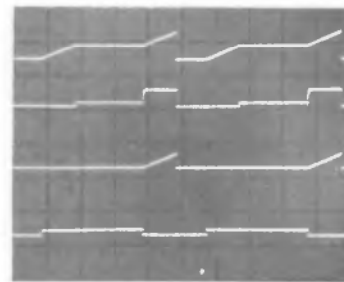

Waveform SS6-2

and the oscilloscope CRT display should consist of four straight horizontal lines. If the scan does not stop when TP 4 is grounded, place the model 8443A MODE switch in the EXTERNAL position. The oscilloscope CRT display should be as shown in waveform SS6-3. If the correct waveform is now present, check Q8, Q9, Q20 and U2. If the channel A and channel C displays are correct, but channel B is not, check CR2, CR3 and Q4. If the channel A display is as shown, but B and C are not, check Q5, Q6, Q7 and associated components.

Test 1-e. With the equipment connected as in test 1-c, return the model 8443A MODE switch to MARKER. Place the REF switch on the A5 assembly in the EXT position. The oscilloscope CRT display should appear as four horizontal lines and the analyzer CRT should be blanked. If these conditions exist, proceed to test 1-f. If not, check U1A, U1D, U2, Q3 and associated components.

Test 1-f. With test conditions as described in test 1-e, short pin 2 of U2 to ground. The oscilloscope CRT display should be as shown in waveform SS6-3, and the analyzer CRT baseline should reappear (no marker). If these conditions are met, check U1B, U1C, Q18 and associated components. If trouble persists, the intensity circuit should be checked next. If above conditions are not met, U2 is probably defective.

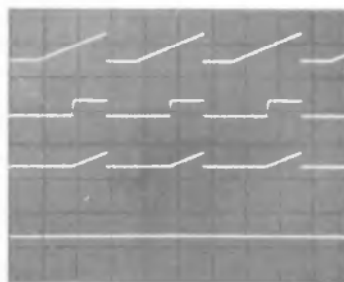

Waveform SS6-3

2 Trigger and Marker Intensity.

The following discussion assumes that the model 8443A is operating in the MARKER mode.

When Q1 is turned on as the scan stops, the positive-going signal at Q1-c is coupled through C16 to the base of Q15. Q15 is normally off and the collector is at +5 volts (the +5 volts is provided by the time base circuit). Due to the time constant of C16 and R21, the signal from Q1-c causes Q15 to conduct for about 200 microseconds; this provides a negative-going pulse at Q15-c to trigger the time base flip-flop in the time base circuit.

During the period of time that the analyzer scan ramp is stopped the positive dc level at the collector of Q1 turns on Q12 through the MARKER INTENSITY control. The junction of Q12-c, Q11-c, Q13-b, R29 and C17 will be designated as a "current node" for purposes of discussion in the rest of this text. Q12 acts as a current sink for the current node. The rate at which C17 is discharged is determined by the setting of the MARKER INTENSITY control; the more heavily Q12 conducts, the shorter the discharge time of C17. When the MARKER INTENSITY control is turned cw, conduction of Q12 decreases, and more time is required to discharge C17 to the ground reference level; this results in extending the period of time that the scan is stopped to provide a brighter marker. Q13 and Q14 act as a differential amplifier to sense when C17 has been discharged to ground reference.

Initially (before Q12 is turned on), C17 is charged, Q13 is conducting and Q14 is turned off. Since Q14 is off, so are Q11 and Q10. When Q12 is turned on C17 begins to discharge. When the current node reaches the ground reference established by Q14, both Q13 and Q14 are conducting. When Q14 conducts, the voltage at the base of Q11 is reduced and Q11 conducts; current is now being sourced to the current node by Q11 and R29 at the same rate that current is being sunk from the current node by Q12. When Q11 conducts the voltage on the base of Q10 decreases, Q10 conducts and Q18 is turned on.

When Q18 conducts U1C pin 9 goes high (about +4 volts). If the count acknowledge signal is a high at U1C pin 10, U1C pin 8 goes low and the stopenable flip-flop, U2, is cleared. This disables the active clamp current sink and permits the analyzer scan to continue. If Q18 conducts before the count acknowledge signal at U1C pin 10 goes high, the high dc level at Q18-e blanks the analyzer CRT through R33 and CR16 until the count acknowledge signal goes positive. The count acknowledge signal also turns on Q19 which for all practical purposes provides a ground at the junction of R33

and CR16, this prevents the CRT display in the spectrum analyzer from being blanked when the scan ramp is released and the scan ramp continues to the limits set by the analyzer.

Test Procedure **2**

General

When the instrument is functioning properly, the waveforms shown in SS6-4 will appear at the following points: A - Q1-b, B - A5TP2, C - junction of Q11-c/Q12-c/Q13-c and D - Q18-b.

Initial Control Settings (for waveform SS6-4)

Spectrum Analyzer: (control settings not listed are not important)

SCAN TIME
PER DIVISION 1 MILLISECOND
SCAN MODE INT
SCAN TRIGGER AUTO

Tracking Generator/Counter

Mode MARKER
RESOLUTION 100 Hz
MARKER INTENSITY Full CW
MARKER POSITION KNOB Pulled out

Oscilloscope

Triggered by Analyzer SCAN IN/OUT

Time/DIV 5 Milliseconds
VOLTS/DIV A - .2
B - .5
C - .05
D - 5

DC inputs 10:1 probes

Test 2-a. Connect the digital voltmeter from Q13-b to ground. The average dc level measured should vary considerable with rotation of the MARKER INTENSITY control (the level should be higher when the control is full cw). In the SCAN HOLD and MARKER modes the average voltage read should be below 1 volt. In the EXTERNAL mode the dc level should rise to approximately 18.5 volts. Proceed to test 2-b.

Test 2-b. If the dc level remains at about +18.5 volts in test 2-a in all positions of the MODE control switch, connect a 10K ohm resistor between Q1-b and the -12 volt supply (XA7-5) with the MODE switch in the EXTERNAL position. The digital voltmeter should indicate the same dc levels specified for the SCAN HOLD mode shown above. If the voltage level still remains at about +18.5 volts, check Q1, Q12, the MARKER INTENSITY control and associated components. If the voltage drops to the level specified for the SCAN HOLD mode in test 2-a, and the scan can be stopped in the SCAN HOLD mode, Q8 may be defective. If the dc levels differ greatly from those listed in tests 2-a and 2-b, check Q13, Q14 and associated components.

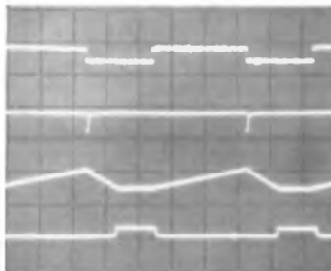

Waveform SS6-4

Test 2-c. If the dc levels for the SCAN HOLD and EXTERNAL modes were as specified in test 3-a and the instrument functions properly in these modes, but will not function in the MARKER mode, check Q10 and Q18. (Q18 may have been checked in test procedure 1-f.)

3 Blanking, Scan Hold, External and Zero Scan

Whenever the blanking signal is high (from the analyzer or originating in the model 8443A), Q3 conducts. When the blanking is originating in the model 8443A the high input at pin 2 of U1A has no effect because U1B is holding pin 1 of U1A low. When the model 8443A blanking pulse ends, pin 9 of U1C and pin 5 of U1B go low and pin 6 of U1B and pin 1 of U1A go high. However, Q3 has stopped conducting and the output of U1A at pin 3 remains unchanged. When the analyzer scan ramp ends and the analyzer blanking begins, Q3 again conducts. Now both inputs to U1A are high and the output, pin 3, goes low. The output of U1D pin 11 goes high, but this has no effect on U2 since U2 is clocked only on negative-going signals. When the analyzer blanking pulse ends, Q3 is turned off, U1A output (pin 3) goes high and pin 11 of U1D goes low. This clocks the stop-enable flip-flop (U2) and enables the active clamp.

In the SCAN HOLD mode CR11 and CR22 cathodes are grounded. CR22 provides a continuous ground (enable) to the count trigger output. CR11 prevents Q18 from conducting. This disables the model 8443A blanking to the analyzer and also holds pin 9 of U1C low to prevent U2 from being cleared. The count periods are separated only by the time it takes the time base circuit to provide transfer and reset pulses and provide a toggle to the main gate flip-flop in the high frequency decade. The count acknowledge has no effect on the counter in the scan hold mode.

In the EXTERNAL mode the cathode of CR10 is grounded and U2 cannot be clocked. The counter trigger is held low by Q17, which is initially conducting. When the count acknowledge signal is re-

ceived Q16 is turned on. C18 couples the signal to the base of Q17 through CR17 to turn off Q17. This causes the count trigger signal to go high. Q17 stays off for a period of time determined by C18 and R40. When C18 has charged up to approximately 1.4 volts as determined by CR17 and the emitter-base junction of Q17, Q17 again conducts and causes the count trigger to go low. The count periods are separated by the time Q17 is off, the transfer and reset pulse periods and the time required for the time base circuit to toggle the main gate flip-flop in the high frequency decade.

When the analyzer is operated in the ZERO scan mode, and the model 8443A is in the MARKER mode, the marker control circuit works as it did in the EXTERNAL mode except that the low at test point 3 is provided by CR21 instead of a ground being provided by the MODE switch. When the analyzer is not in the ZERO scan mode, there is about -10 volts on the blanking coax shield. This causes Q2 to conduct and reverse bias CR21. When the analyzer is operating in the ZERO scan mode the -10 volts is no longer on the blanking coax shield, and Q2 is turned off. Q2-c is held slightly below ground by CR20, CR21 is forward biased and test point 3 is essentially at ground potential. Q16 and Q17 operate as they did in the EXTERNAL mode.

Test Procedure **3**

General

When this portion of the marker control assembly is functioning properly in the MARKER mode, the critical points in the circuit will be working as indicated in waveform SS6-5. These waveforms represent the following: A — Q3-e blanking, B — U1C pin 9 internal blanking, C — the count acknowledge signal and D — U1C pin 8.

Initial Control Settings (for waveform SS6-5)

Control settings are the same as those specified for waveform SS6-4 except for oscilloscope VOLTS/DIV. A — 1, B — 5, C — .5 and D — 1.

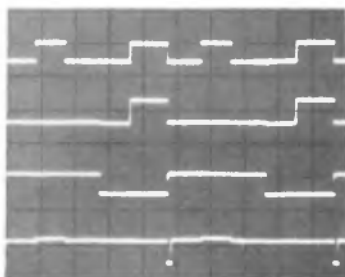

Waveform SS6-5

Test 3-a. Connect the oscilloscope as follows: Channel A — U1 pin 9, Channel B — U1 pin 10, Channel C — U1 pin 8 and Channel D — Q3-e. Set oscilloscope VOLTS/DIV to .5 for all channels. The oscilloscope CRT display should be as shown in waveform SS6-6. (Model 8443A in MARKER mode.) Note that the Channel C waveform goes negative only during the short period of time that the Channels A and B waveform are both high. If the waveforms are not correct, proceed to test 3-b.

Test 3-b. Connect the digital voltmeter between pin 9 of U1 and ground, and set the RESOLUTION control to 10 Hz. In the EXTERNAL mode the digital voltmeter should indicate about -590 mVolts. In the MARKER mode the digital voltmeter should indicate about +3 volts. In the SCAN HOLD mode the digital voltmeter should indicate about -580 mVolts. If the dc level is high (+4 volts or more) the model 8443A is in the MARKER mode and the scan remains stopped, apply a ground to U1 pin 8; the scan should continue. If the scan does not continue, check U2. If it does, check U1.

Test 3-c. If waveform D is SS6-6 is incorrect, check for the same waveform (slightly higher in amplitude) at Test Point 1. If the waveform is present at TP 1, but not at Q3-e, Q3 is probably defective. If the waveform is not present at either point, check the cabling to the analyzer.

Test 3-d. If the model 8443A functions properly in the MARKER mode but does not function in the EXTERNAL mode, check Q16, Q17, the MODE switch and associated components.

Test 3-e. If the model 8443A will not function properly in the SCAN HOLD mode, but does in other modes, check CR11, CR22 and the MODE switch.

Test 3-f. If the counter will not work when the analyzer is placed in the ZERO scan mode, check Q2 and associated components.

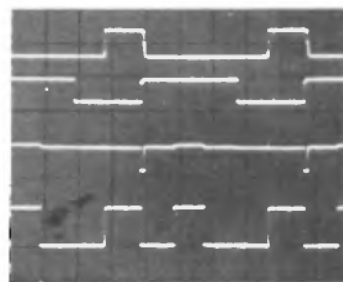

Waveform SS6-6

A7 TOP VIEW



A7

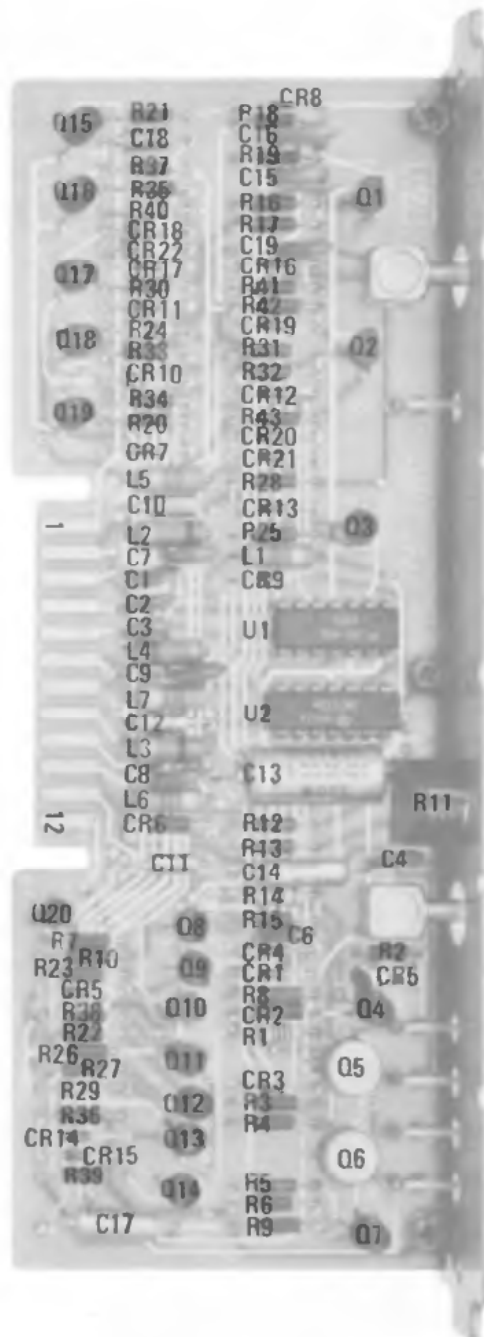
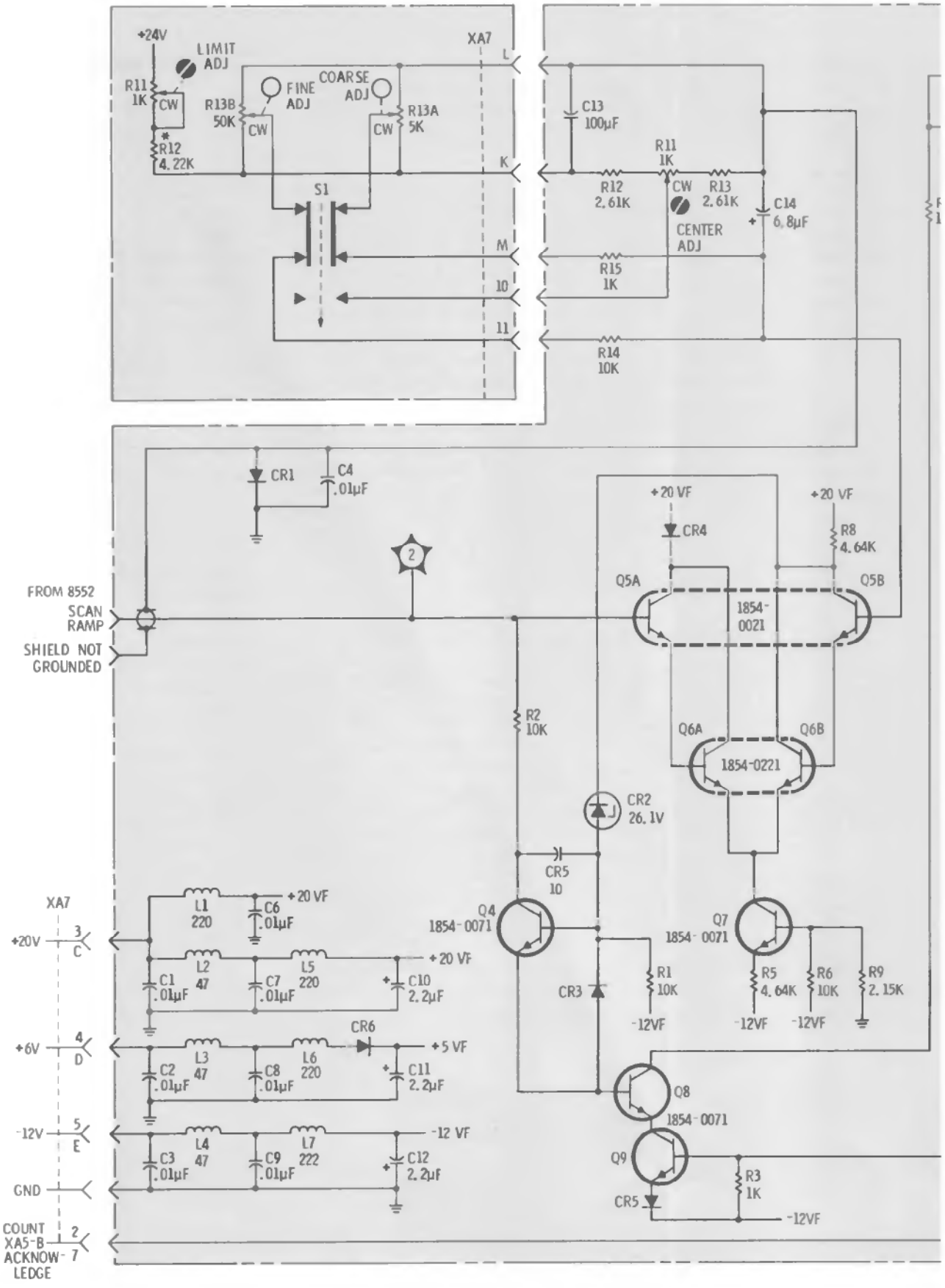
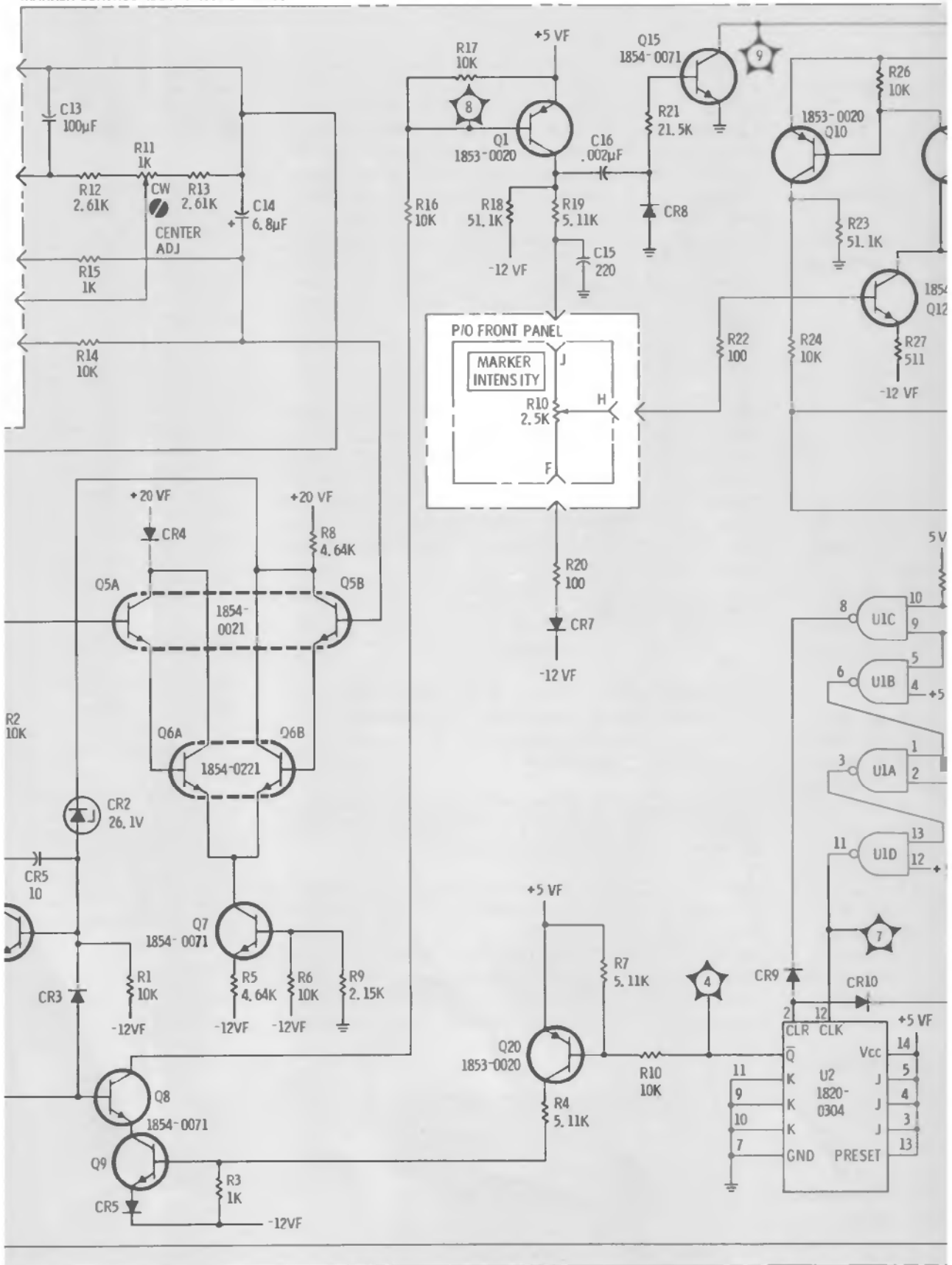

Figure 8-32. A7, Marker Control Assembly, Cover and Components

MARKER CONTROL ASSY A7 (08443-60046)



MARKER CONTROL ASSY A7 (08443-60046)



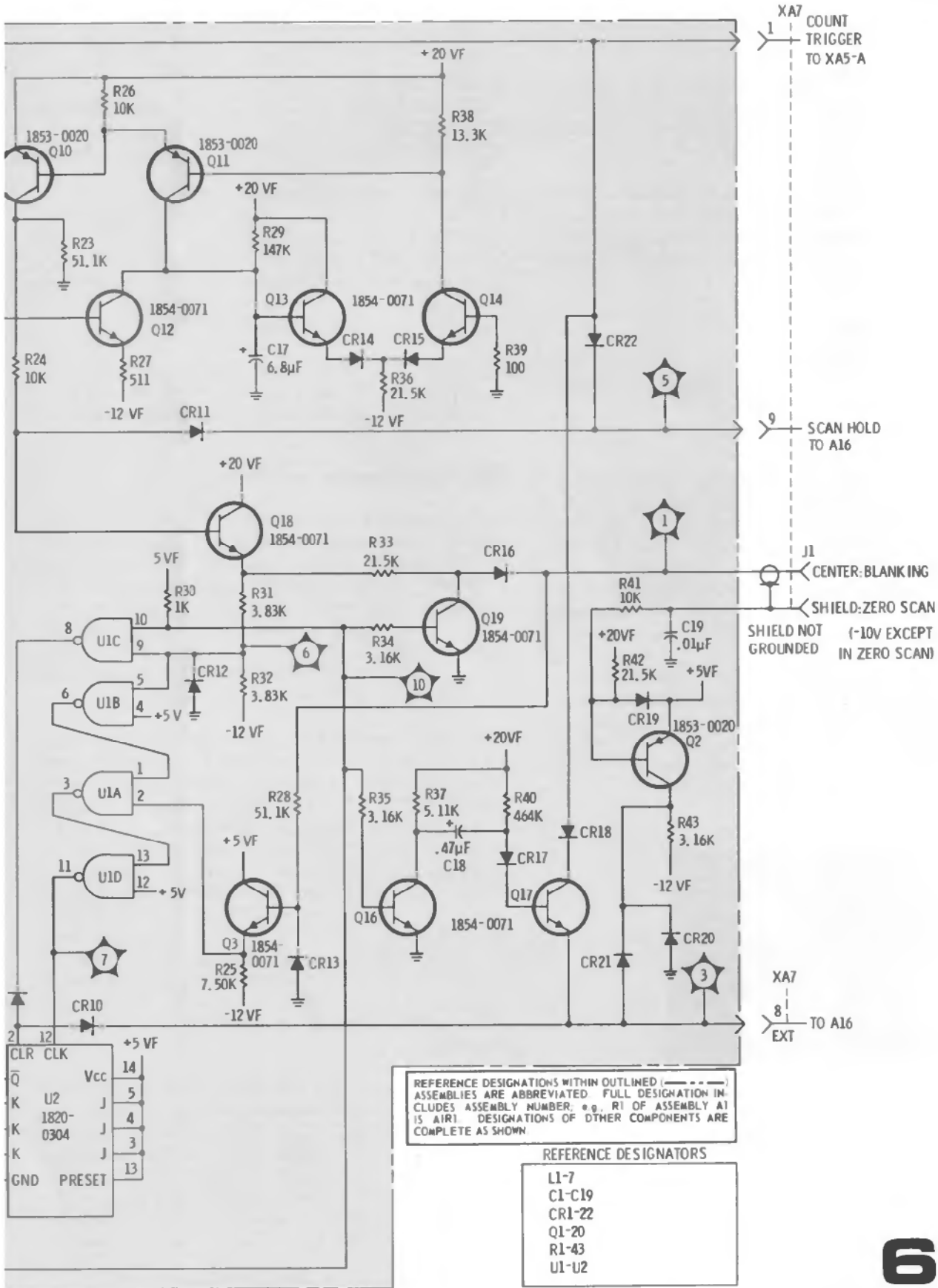

6

Figure 8-33. Marker Control Circuit, Schematic Diagram

Section VIII
Service

SERVICE SHEET 7

Normally causes of malfunction in the model 8443A circuits will be isolated to a circuit board or assembly as a result of performing the tests specified in the Troubleshooting Tree.

When trouble has been isolated to the time base assembly (A5), it should be removed from the chassis and reinstalled using an extender board. This will provide easy access to test points and components.

Equipment Required

4 Channel Oscilloscope	Service Kit
10:1 Oscilloscope	Digital Voltmeter
Probes (4)	

General

The time base assembly contains circuits which provide transfer and reset pulses for all decade counters, a count acknowledge signal to the marker control circuit, a gate toggle signal for the high frequency decade, a print command for use in external equipment and a buffer amplifier to provide a 1 MHz output for use in external equipment.

When the time base assembly is functioning properly, the waveforms shown on composite waveform SS7-1 will appear at the six test points which are available at the top cover of the assembly. The functions of the waveforms are listed directly below the composite waveform.

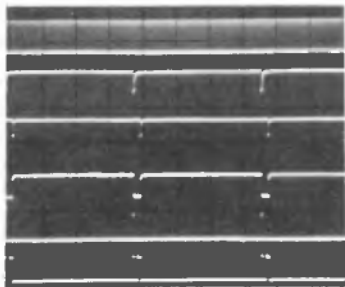

Composite Waveform SS7-1

- Trace 1. 1 MHz Reference Signal.
- Trace 2. Input Trigger Signal.
- Trace 3. Transfer Pulse.
- Trace 4. Count Acknowledge Signal.
- Trace 5. Reset Pulse.
- Trace 6. Gate Toggle.

Initial Control Settings (for above waveforms)

Spectrum Analyzer (controls not listed may be set anywhere)

SCAN TIME
 PER DIVISION 1 MILLISECOND
 SCAN MODE INT
 SCAN TRIGGER AUTO

Tracking Generator/Counter

MODE MARKER
 RESOLUTION 1 kHz
 MARKER INTENSITY Full CW
 MARKER POSITION knob Pulled Out

Note

For all tests using the oscilloscope synchronize the oscilloscope to the analyzer SCAN IN/OUT unless otherwise noted.

1 Trigger, Transfer and Reset

Q5 is normally conducting; pin A of XA5 is connected to the open collector of a transistor, Q15, in the marker control circuit. When the trigger goes low, Q5 is turned off. Q4 is normally off; it conducts only when the inhibit signal is high. (The inhibit signal is provided by external equipment connected to the rear panel BCD output connector when such equipment needs more time to process the previous count.)

When Q5-c and NAND gate pin 1 U1A go high, U1A pin 3 goes low because U1A pin 2 is high when the count trigger is received. C10, between pins 1 and 3 of U1A, prevents loop oscillations from occurring. When pin 3 of U1A goes low, pin 6 of NAND gate U1B goes high and turns on Q7 to begin the reset pulse. The reset pulse for U4, U3A, U3B, U5A and U5B is provided directly from the output of NAND gate U1B because these dividers require that current be sunk from them. Because the decade dividers in the high frequency decade require current to be sourced to their reset inputs, Q7 is required. NAND gate U1B cannot provide enough current for these decades.

The reset signal is a pulse of about 50 microseconds duration, as determined by the time constant of R16 and C12. R16 and C12 delay the application of the trigger pulse to the clear input of the time base flip-flop, U2, for 50 microseconds. When U2 is cleared the Q output goes low, U1A pin 2 goes low, U1A pin 3 goes high and pin 6 of U1B goes high to end the reset pulse.

When the count has been completed the main gate flip-flop in the high frequency decade provides a signal to clock the time base flip-flop, U2. C14 delays application of the end-of-count signal

to the U2 clock input to assure that the transfer pulse will be applied to U15B in the low frequency counter after the overflow information has been stored. The delay is required because the D input of a type D flip-flop should not be changed while the clock input is low. When U2 is clocked, the \bar{Q} output goes low and the Q output goes high. NAND gate U1C pin 10 goes high and pin 8 goes low for about 150 microseconds due to the time constant of R10 and C9. This 150 microsecond pulse from U1C transfers the information in the low frequency counter blanking decade counters to the buffer stores. The high Q output of U2 also provides the count acknowledge signal to the marker control circuit.

CR2, CR3 and CR4 prevent the start of the reset pulse while the transfer pulse is present. When the transfer pulse is present, CR3 and CR4 are reverse biased and the -12 volt source forward biases CR2 to prevent a high from appearing on U1A pin 1. When the transfer pulse is not present, CR3 and CR4 are forward biased and CR2 is reverse biased.

Test Procedure 1

Note

These tests assume that trouble has been isolated to the time base assembly as a result of performing the troubleshooting procedures.

Test 1-a. Use the digital voltmeter to verify the presence of dc voltages at terminals 4/D and 5/C as shown on the schematic diagram.

Test 1-b. Connect the oscilloscope as follows: Channel A to Q5-c, Channel B to U1-3, Channel C to U1-6 and Channel D to Q7-e. All channels set to .5 V/Div, TIME/DIV to 5 mSec. The oscilloscope display should be as shown in Waveform SS7-2. If the display is correct, use one of the oscilloscope channels to check the transfer signal

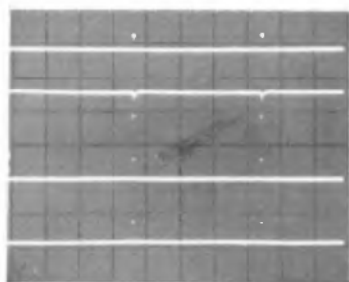

Waveform SS7-2

at TP-3. The waveform should be as shown in trace 3 of composite waveform SS7-1. If the waveforms are correct proceed to test procedure 2, if not, proceed to test 1-c.

Test 1-c. With the oscilloscope connected as it was for waveform SS7-2, set the oscilloscope TIME/DIV to 1 mSec and sync to internal. Place the model 8443A MODE switch to SCAN HOLD. The oscilloscope display should be as shown in waveform SS7-3. If the display is correct, but was not correct in test 1-b, trouble is in the marker control circuit. If waveform A is correct, and none of the others are correct, check U1A. If waveforms A and B are correct and C and D are not, check U1B. If only waveform D is incorrect, Q7 is probably defective. Use one of the oscilloscope probes to check the transfer pulse at TP 3. The transfer pulse should be in time coincidence with the input trigger pulse, and almost identical to it in appearance. If the waveforms shown in SS7-3 are correct and the transfer pulse is not, check U1C, CR2, CR3, CR4 and associated components.

2 Reference Signal Amplifiers and Gate

The reference signal (internal or external) is selected by a switch, A5S1, located on the cover of the A5 assembly. L5 and C5 form a 1 MHz series resonant tank. R4 and the intrinsic resistance of Q2 provides a 50 ohm load for the reference source. Q2 is a common base amplifier with a voltage gain of ten. Q3 is a common emitter amplifier which saturates on positive half cycles of the reference signal. Q1 is a buffer amplifier which serves to isolate the time base circuits from external loads when the 1 MHz reference output is used in external equipment.

NAND gate U1D couples the 1 MHz reference signal to the first divide-by-ten circuit, U4, when the \bar{Q} signal from U2 is high.

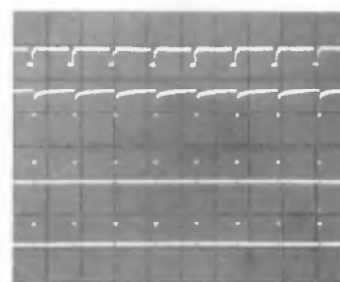

Waveform SS7-3

Test Procedure 2

Test 2-a. Connect the oscilloscope Channel A to R17/R29 junction, Channel B to U1-13, Channel C to U1-11 and Channel D to U1-12. The oscilloscope display should be as shown in waveform SS7-4. If the oscilloscope Channel B signal is not present, the other signals cannot be present either, because they are derived from the divide-by-ten circuits. If the Channel B signal is not present check for it first, at the base of Q3, then at the emitter of Q2. After making repairs, if the oscilloscope display is as shown in SS7-4, and the counter still does not function properly, proceed to test procedure 3.

2 Divide-by-Ten Circuits

The divide-by-ten circuits (U4, U3A, U3B, U5A and U5B) are reset when pin 6 of U1B goes high. U4 is set to zero and the other four dividers are set to nine. When NAND gate U1D couples the reference signal to U4, U4 provides an output to reset the last four dividers to zero on the tenth input pulse. At the time the last four dividers are set to zero, a pulse from one of the last three dividers (the divider output selected is determined by the position of the RESOLUTION switch) is provided to toggle the main gate flip-flop in the high frequency decade.

The outputs from the last three dividers, which are used to toggle the main gate flip-flop in the high frequency decade, are wired together in an OR configuration. Only one of the three outputs is available at any given time; the output from the divider selected is enabled by a ground return from the resolution switch. U3B provides the 1 kHz resolution, U5A provides the 100 Hz resolution and U5B provides the 10 Hz resolution. The resolution switch also provides a ground to one of three inputs in the low frequency counter to cause the decimal point in one of three numerical readouts to illuminate.

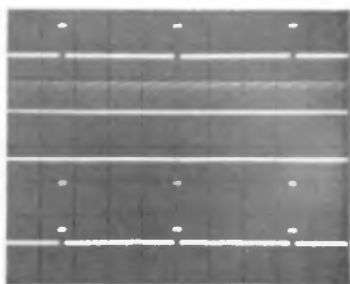

Waveform SS7-4

The 1K resistors in the outputs of the divide-by-ten circuits are the pullup resistors. The outputs in these dividers are open collectors and the resistors are required to provide wired OR capabilities.

When the end-of-count signal from the high frequency decade goes low, Q6 is turned off and a high is provided as an external print command to devices connected to the model 8443A rear panel BCD output connector.

Test Procedure 2

Test 3-a. Composite waveform SS7-5 illustrates the correct gate toggle outputs from the time base circuit for various settings of the RESOLUTION switch referenced to the analyzer scan ramp.

Waveform 1 represents an analyzer scan time of 1 mSec per division, displayed on the oscilloscope at 5 mSec per division. Waveform 2 is the gate toggle pulse with the model 8443A in the 1 kHz resolution mode. Waveform 3 is the gate toggle pulse with the model 8443A in the 100 Hz resolution mode. Waveform 4 is the analyzer scan (1 mSec/Div) displayed on the oscilloscope at 20 mSec/Div and waveform 5 is the gate toggle with the model 8443A in the 10 Hz resolution mode.

Service Note

If the model 8443A works properly in the MARKER mode at 100 Hz and 1 kHz, but not at 10 Hz, U5B is defective. If it works at 1 kHz, but not at 100 Hz or 10 Hz, U5A is defective.

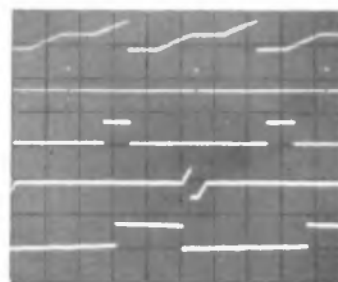

Composite Waveform SS7-5

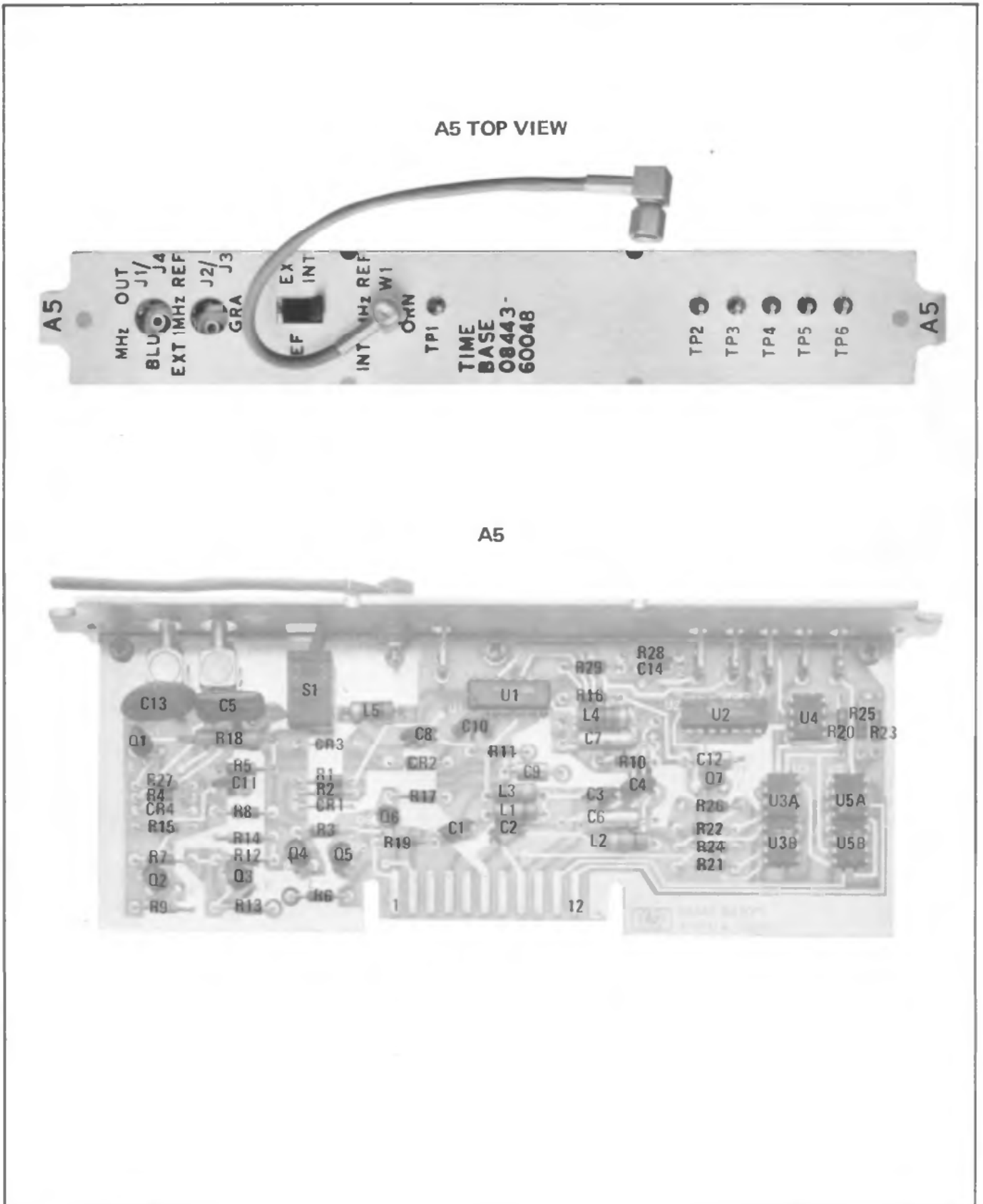
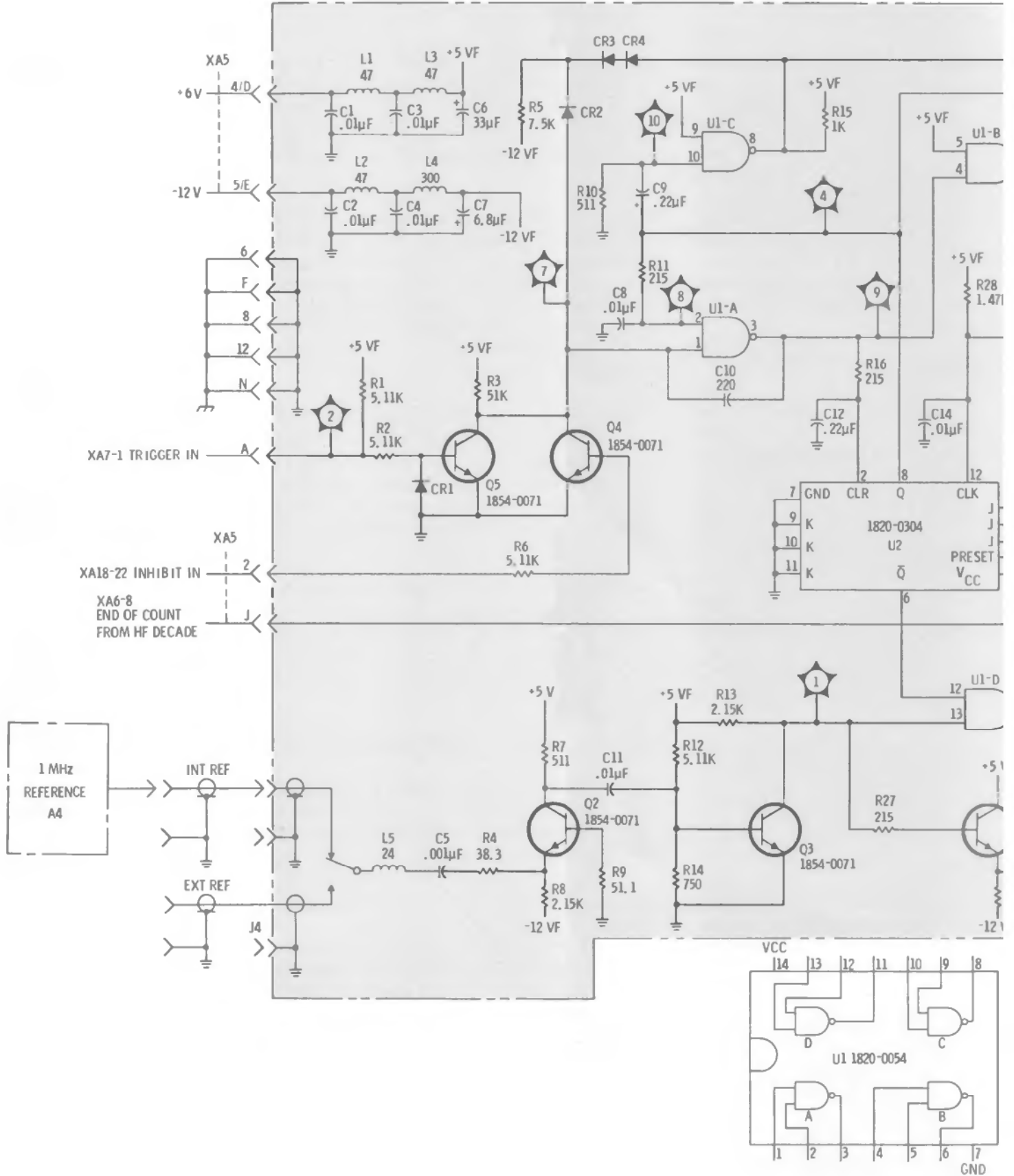
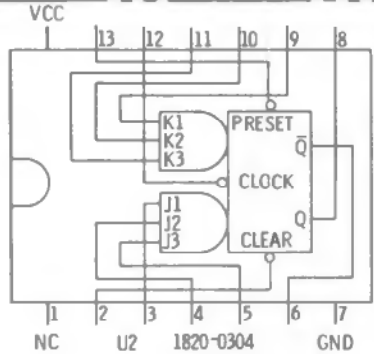
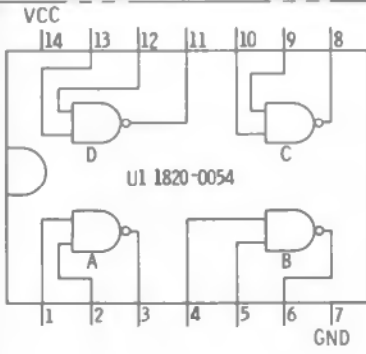
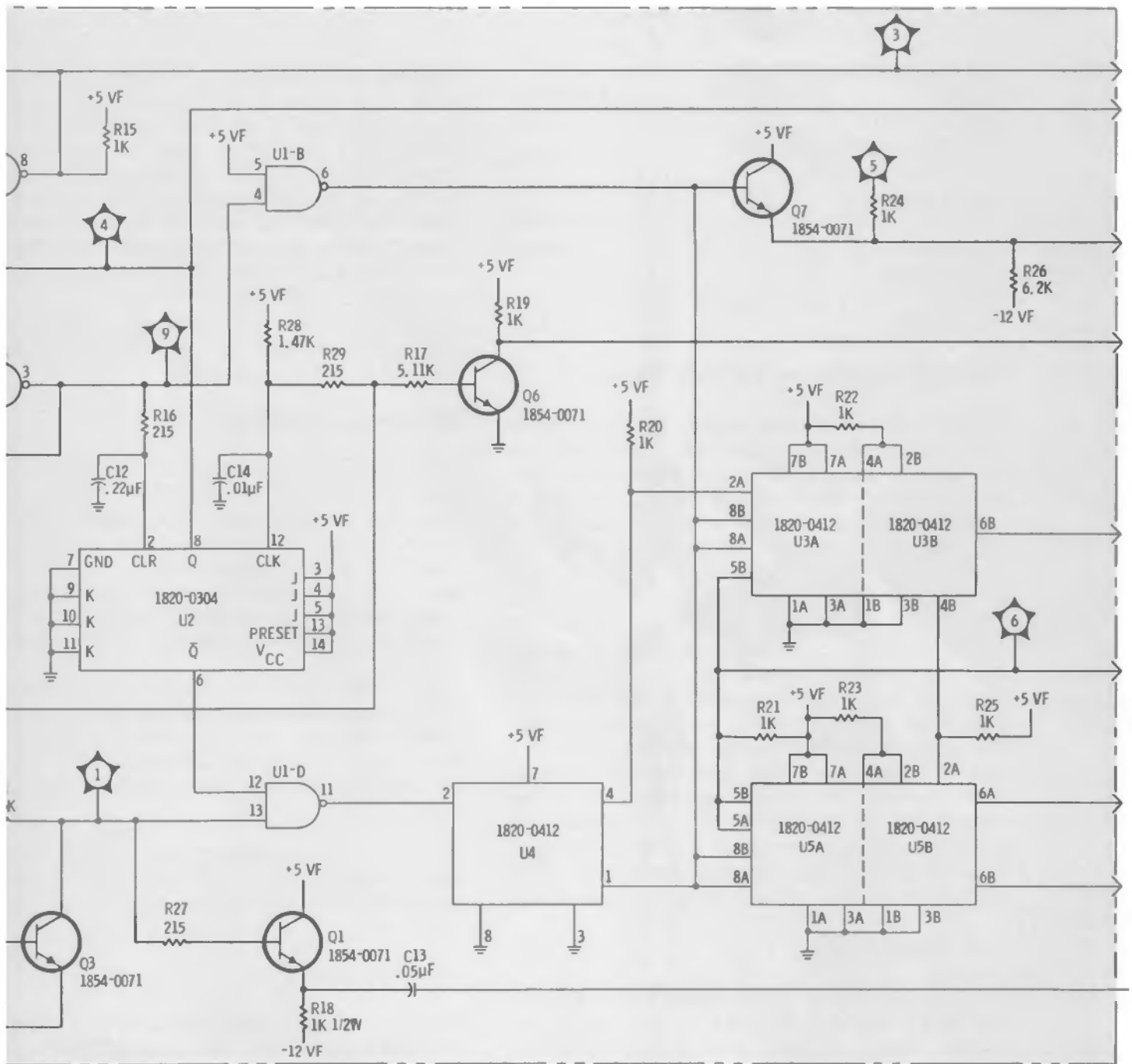

Figure 8-34. A5, Time Base Assembly, Cover and Components

TIME BASE ASSEMBLY A5 (08443-60048)





REFERENCE DESIGNATORS	
A5	
C1-14	R1-29
CR1-4	S1
L1-5	U1-5
Q1-5	

REFERENCE DESIGNATIONS WITHIN OUTLINED (---) ASSEMBLIES ARE ABBREVIATED. FULL DESIGNATION INCLUDES ASSEMBLY NUMBER. e.g., R1 OF ASSEMBLY A1 IS A1R1. DESIGNATIONS OF OTHER COMPONENTS ARE COMPLETE AS SHOWN.

Figure

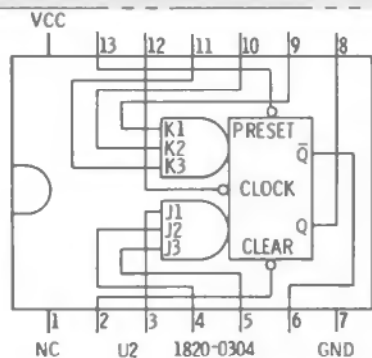
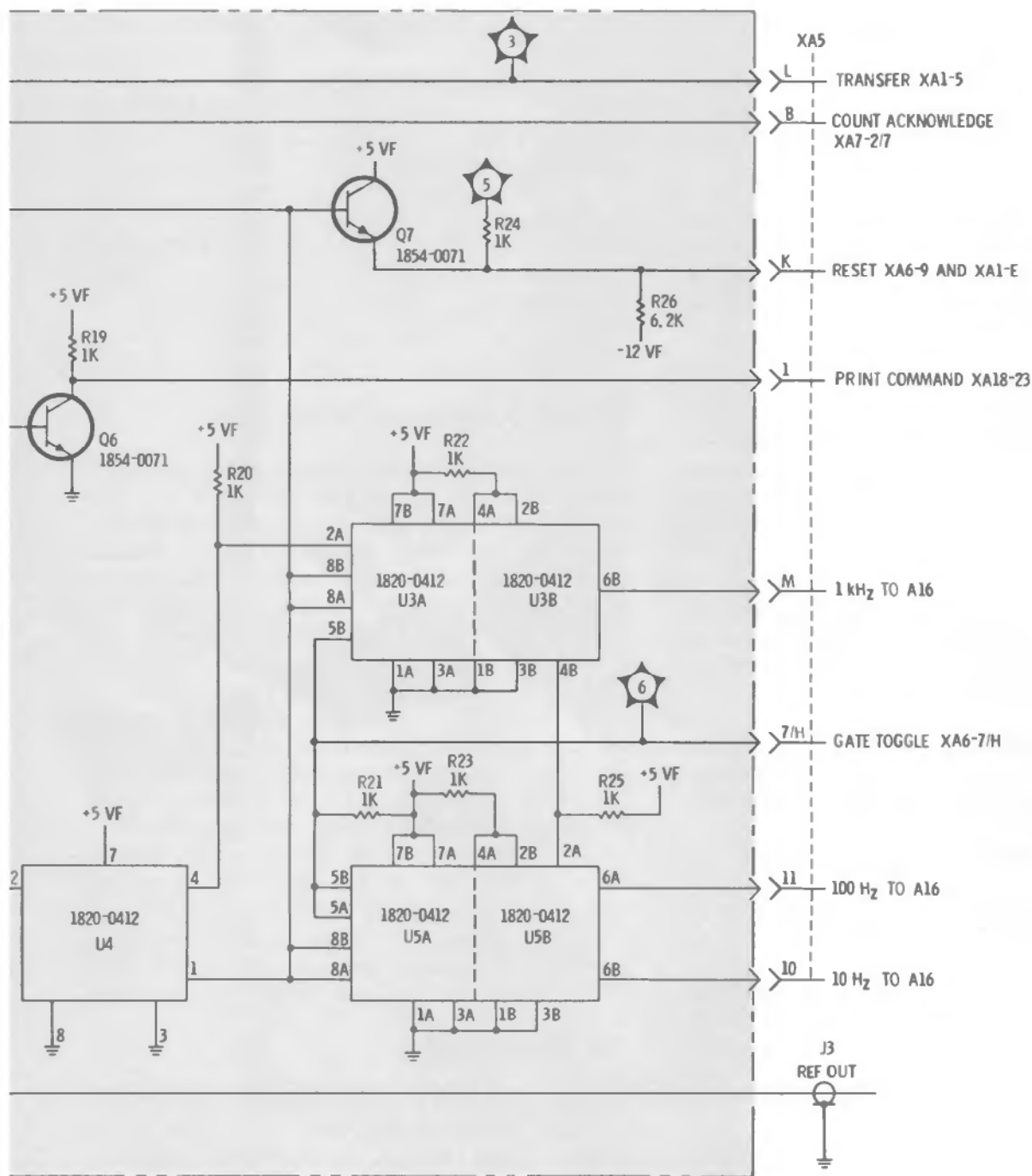

REFERENCE DESIGNATORS

A5	
C1-14	R1-29
CR1-4	S1
L1-5	U1-5
Q1-5	

REFERENCE DESIGNATIONS WITHIN OUTLINED (---) ASSEMBLIES ARE ABBREVIATED. FULL DESIGNATION INCLUDES ASSEMBLY NUMBER, e.g., R1 OF ASSEMBLY A1 IS A1R1. DESIGNATIONS OF OTHER COMPONENTS ARE COMPLETE AS SHOWN.



Figure 8-35. Time Base Circuit, Schematic Diagram

**Section VIII
Service**

SERVICE SHEET 8

Normally, causes of malfunction in the model 8443A circuits will be isolated to a circuit board or assembly as a result of performing the tests specified in the Troubleshooting Tree.

When trouble has been isolated to the high frequency decade assembly (A6), it should be removed from the chassis and reinstalled using an extender board. This will provide easy access to test points and components.

Equipment Required

- | | |
|------------------------------|--|
| 4 Channel Oscilloscope | Service Kit |
| 10:1 Oscilloscope Probes (4) | HF Signal Generator
Digital Voltmeter |

General

The major purpose of the high frequency decade is to divide the input frequency by ten and supply suitable signals to drive the circuits in the low frequency counter assembly.

When the high frequency decade is functioning properly, the outputs to the low frequency counter will appear as shown in waveform SS8-1.

Initial Control Settings (for waveform SS8-1)

Spectrum Analyzer (setting of controls not listed is unimportant)

- | | |
|------------------------|---------------|
| SCAN WIDTH | |
| PER DIVISION | 10 MHz |
| SCAN WIDTH | PER DIVISION |
| FREQUENCY | 10 MHz |
| SCAN TIME | |
| PER DIVISION | 1 MILLISECOND |
| SCAN MODE | INT |
| SCAN TRIGGER | AUTO |

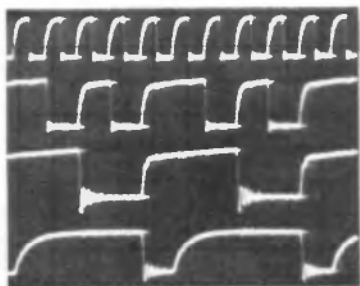

Waveform SS8-1

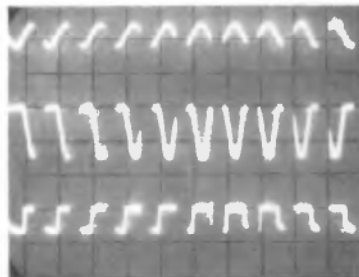

Waveform SS8-2

Tracking Generator/Counter

- | | |
|-------------------------------|------------|
| MODE | SCAN HOLD |
| RESOLUTION | 100 Hz |
| MARKER CONTROL knob | Pulled out |

Oscilloscope

- | | |
|---------------------|----------|
| SYNC | INTERNAL |
| TIME/DIV | 2 mSec |
| VOLTS/DIV | .2 |
| SLOPE | — |
| TRIGGER | ACF |

1 Input Amplifier and Switching Matrix

Q1 and Q2 provide flat amplification for signals with frequencies up to 120 MHz. L10 and L11 are peaking inductors to peak the gain at the high frequency end of the bandpass. R22 in the Q2 emitter circuit is selected so that a nominal -18 dBm signal will toggle U3. The value of R24 is selected to provide a dc level at pin 8 of U3 that is -900 mV ±30 mV with no signal input. CR1, CR2, CR3, CR4, CR6, CR7, CR8, CR10 and CR11 comprise a switching matrix. When the tracking generator output is used, CR1, CR4, CR6 and CR11 are all forward biased and CR2, CR3, CR7, CR8 and CR10 are all reverse biased. The signal is coupled through C3, CR1, CR6, C17 and L9 to the base of Q1. When the EXTERNAL input is used, the diodes mentioned above are biased directly opposite from the way they are when the tracking generator output is counted. The signal is coupled through C4, C9, C10, CR2, CR7, CR8, CR10, C17 and L9 to the base of Q1.

Test Procedure 1

Test 1-a. Connect a 1 MHz source at +10 dBm to the model 8443A COUNTER INPUT and set the model 8443A MODE switch to EXTERNAL.

Connect the oscilloscope Channel A input to Q1-b, the Channel B input to Q2-b and the Channel C input to U3 pin 8. Set the oscilloscope VOLTS/DIV to .2 for each channel and the TIME/DIV to 1 μ Sec, Trigger INT, ACF and SLOPE +. The waveform should be as shown in waveform SS8-2. If none of the waveforms are present, check the switching matrix. If waveform A is present and B and C are not, check Q1 and associated components. If waveform A and B are present and C is not, check Q2 and associated components. If all of the waveforms are present, proceed to test procedure **2**.

2 Main Gate Flip-Flop

The main gate flip-flop (U2) is toggled by the output of one of the last three dividers in the time base circuit. When U2 is toggled to start the count, Q goes low to enable U3 and \bar{Q} goes high. When U2 is again toggled Q goes high and \bar{Q} goes low, U3 is no longer enabled and the negative-going trailing edge of the Q output of U2 produces an end-of-count signal to the time base.

Gate toggle translator Q5/Q6/Q7 translates the TTL output from the decade dividers in the time base circuit into the ECL input required by U2. Rise time is critical in U2 so a zener circuit such as that used in the reset translator cannot be used.

End of count translator Q3/Q4 translates the ECL output from U2 Q to the TTL logic required to clock the flip-flop in the time base circuit.

Test Procedure **2**

Test 2-a. Set the model 8443A to operate in the MARKER mode with the RESOLUTION control

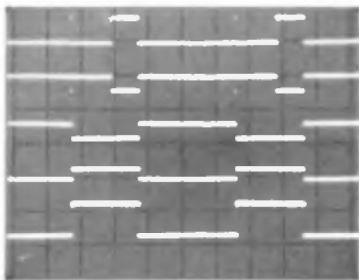

Composite Waveform SS8-3

1. Q6-b Gate toggle from A52 VOLTS/DIV
2. Translated Gate toggle Q5-e2 VOLTS/DIV
3. U2 pin 13 Q output2 VOLTS/DIV
4. U2 pin 1 \bar{Q} output1 VOLTS/DIV
5. Translated \bar{Q} output, TP25 VOLTS/DIV

set to 100 Hz. Set the analyzer SCAN TIME PER DIVISION to 1 MILLISECOND. Synchronize the oscilloscope to the analyzer scan, triggered on + slope, ACF. Waveform SS8-3 is a composite waveform for the five critical circuit points; these points are identified directly below the composite waveform. Oscilloscope VOLTS/DIV information follows identification of test points.

If waveforms 1 and 2 are present and 3, 4, and 5 are not, U2 is probably defective. If waveform 1 is present and 2 is not, check Q5/Q6/Q7 and associated components. If waveforms 1, 2, 3 and 4 are correct and waveform 5 is not, check Q3/Q4 and associated components.

Note

This test assumes that the time base circuit is functioning properly. If waveforms 1 and 3 do not appear, ground TP2 on the A5 assembly. Waveform 1 and 2 should appear (at a much faster rate). If they do, U2 is defective.

2 Reset Translator and Divide-By-Ten Decade.

CR9, a 2.87 volt zener diode is used to translate the TTL input from the reset line to an ECL input compatible with the input requirements of the high frequency decade.

U3, U4, U5 and U6 are feedback connected to provide 1-2-4-8 BCD output to the low frequency counter circuit. U1A, U1B, U1C and U1D comprise a quad ECL to saturated logic translator which makes the ECL output of the decade compatible with TTL used in the low frequency counter circuits. R28/C24, R29/C26 and R30/C27 serve as RFI filters.

The decade dividers convert the 100 kHz to 110 MHz input frequency to an output frequency of 10 kHz to 11 MHz. The A, B, C and D outputs directly drive the buffer/store for the least significant digit in the low frequency counter. In addition the \bar{D} output drives the following blanking decade counter.

Test Procedure 2

Test 3-a. Use the oscilloscope to check for the reset pulse at XA6 pin 9 and at the junction of R11/CR12. The reset pulses should be positive-going, three to four volts in amplitude.

Test 3-b. Set the model 8443A to operate in the MARKER mode at 100 Hz resolution. Set the analyzer SCAN TIME PER DIVISION to 1 MILLISECOND. Connect the oscilloscope Channel A, B, C and D inputs to test points 4, 5, 6 and 7 respectively. Set oscilloscope TIME/DIV to 5 mSec and VOLTS/DIV to .5 for all channels. The oscilloscope display should appear as shown in waveform SS8-4. Since the gate toggle U2 and the input amplifiers have been checked, an output which is not as shown must be due to a defective flip-flop or an associated OR gate. Note that if an output is missing (TP 5 for instance) and following outputs are present (in this instance, TP 6 and TP 7), the only possible cause of trouble is a defective OR gate (U1B).

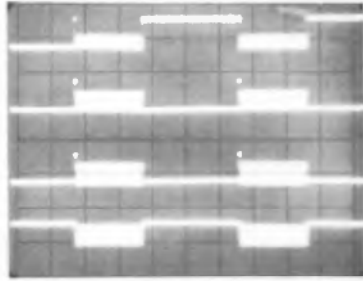

Waveform SS8-4

A6 TOP VIEW

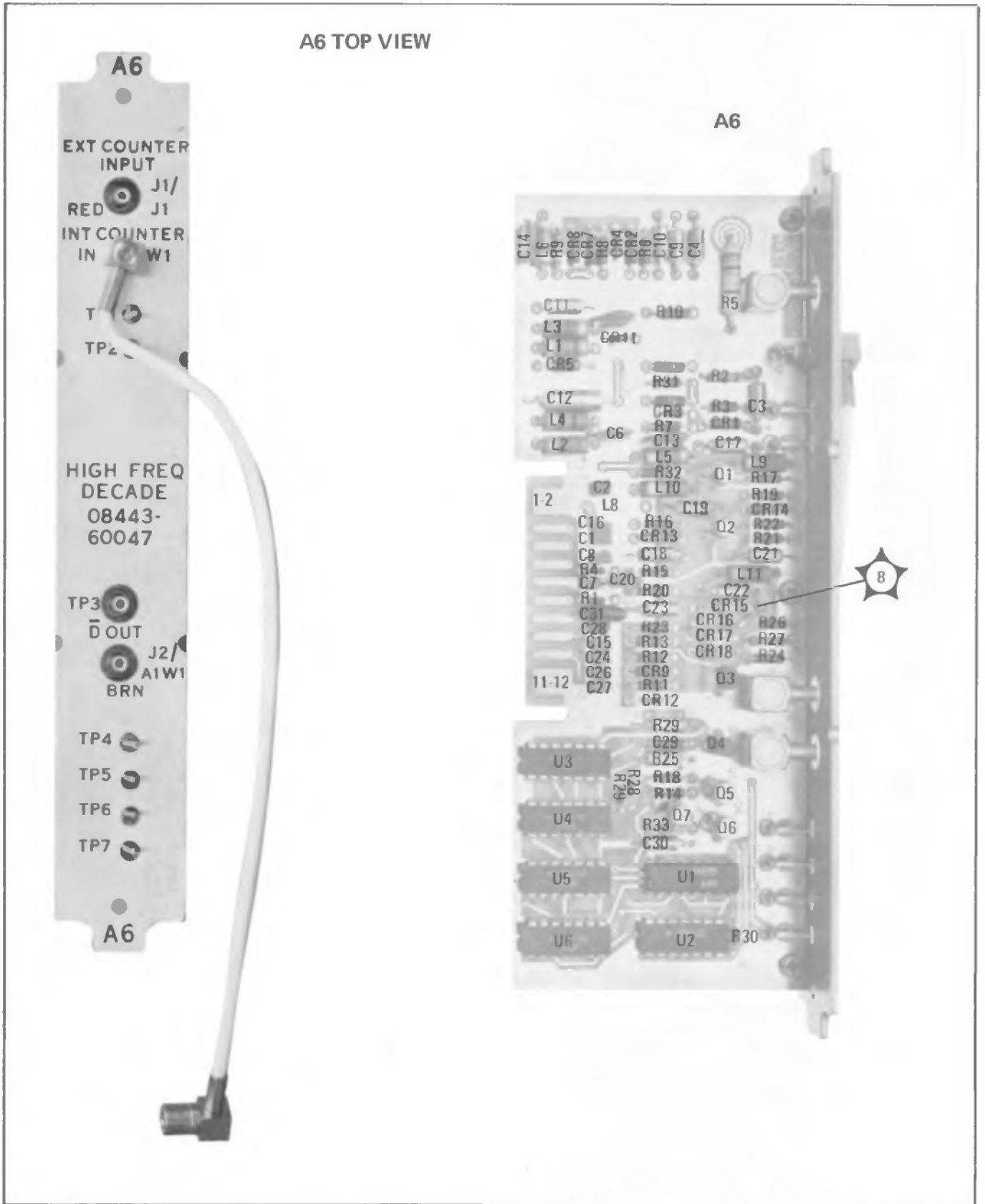
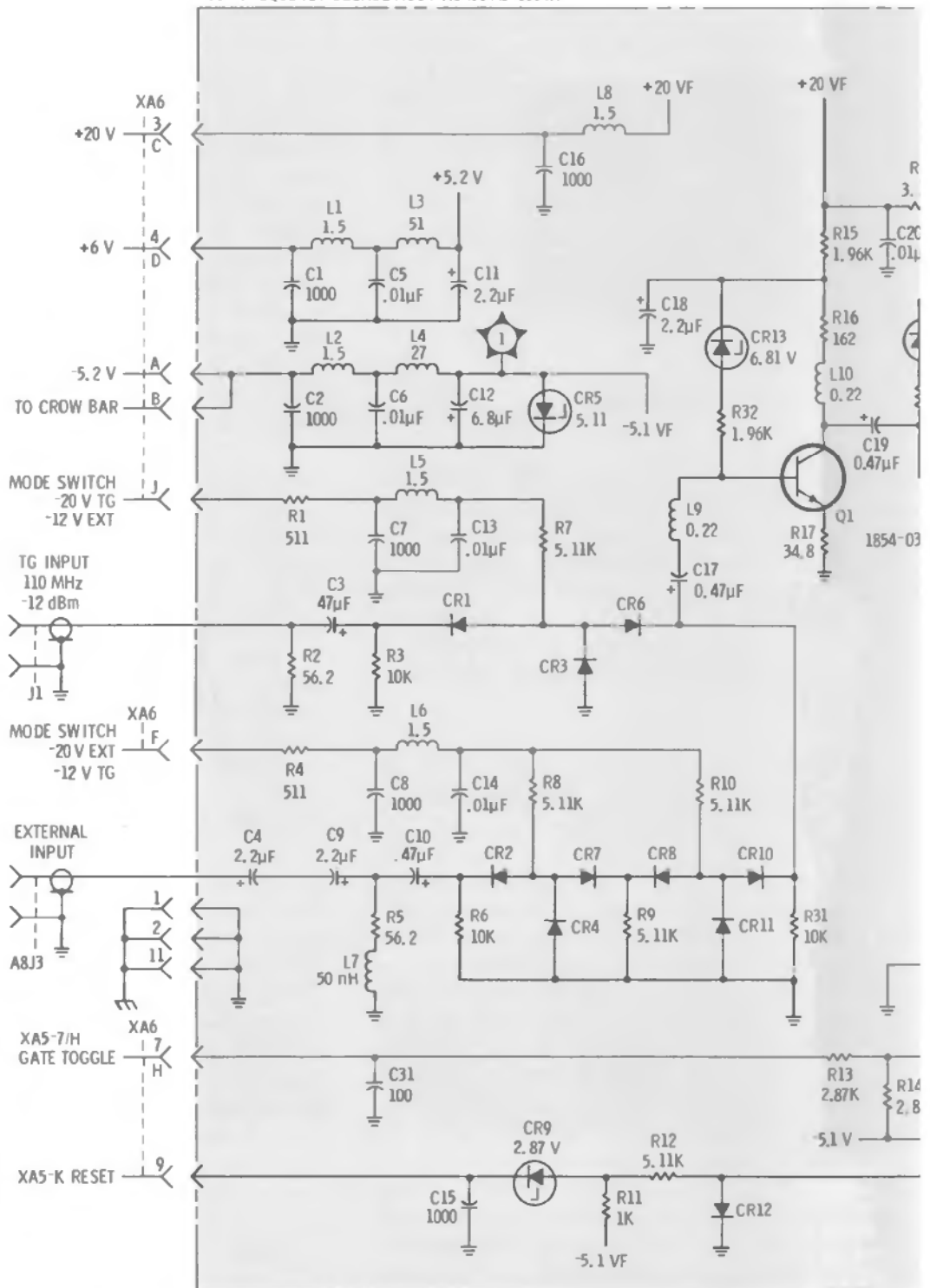
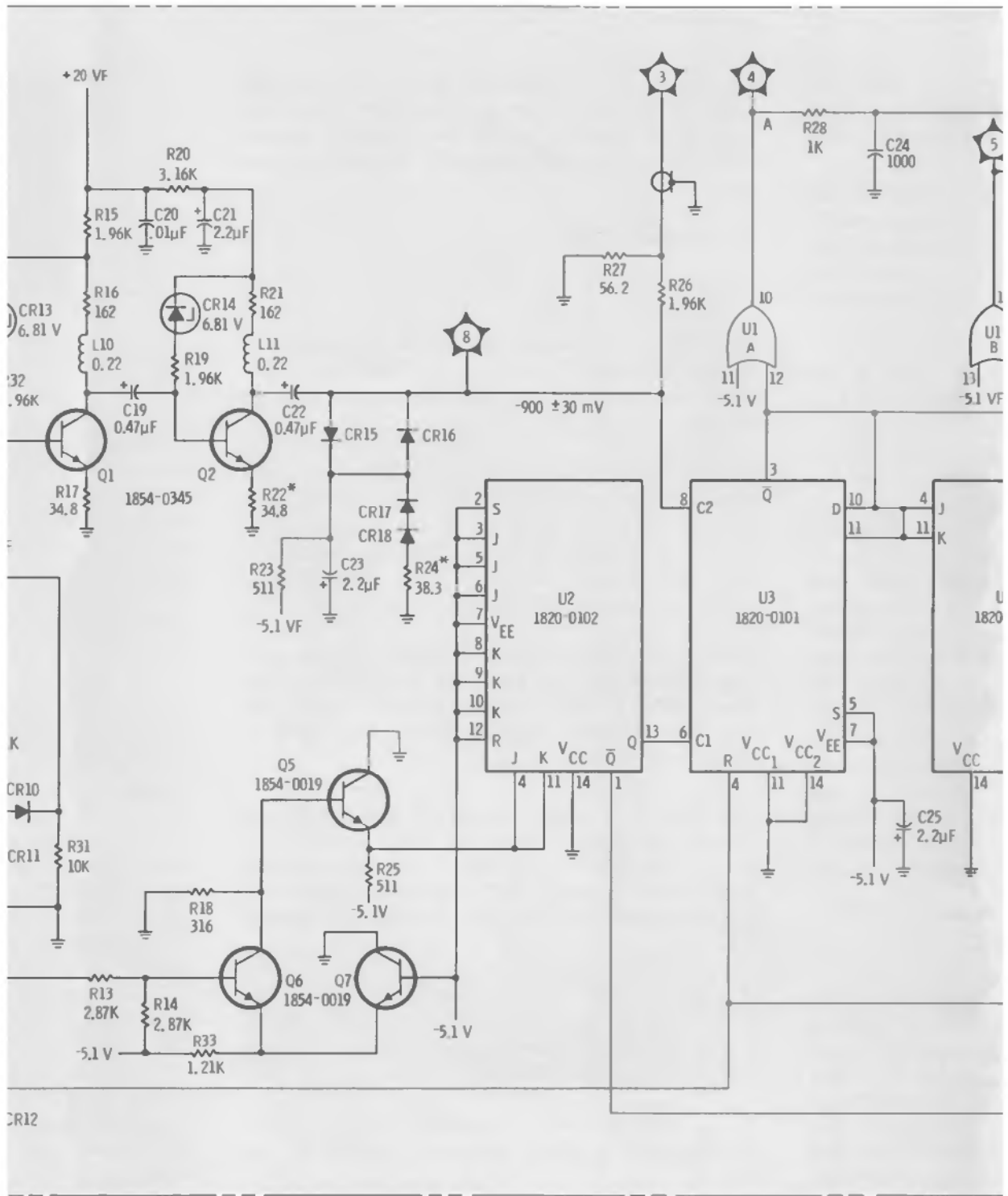

Figure 8-36. A6, High Frequency Decade Assembly, Cover and Components

HIGH FREQUENCY DECADE ASSY A6 (08443-60047)



REFERENCE DESIGNATIONS WITHIN OUR ASSEMBLIES ARE ABBREVIATED. FULL CLUDE'S ASSEMBLY NUMBER, e.g., R1 IS AIR1. DESIGNATIONS OF OTHER COMPLETE AS SHOWN.



DESIGNATIONS WITHIN OUTLINED (---) ARE ABBREVIATED. FULL DESIGNATION IN ASSEMBLY NUMBER, e.g., R1 OF ASSEMBLY A1. DESIGNATIONS OF OTHER COMPONENTS ARE AS SHOWN.

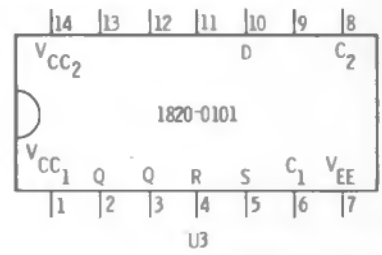
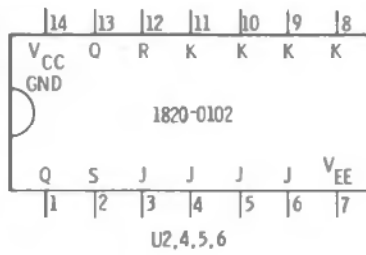

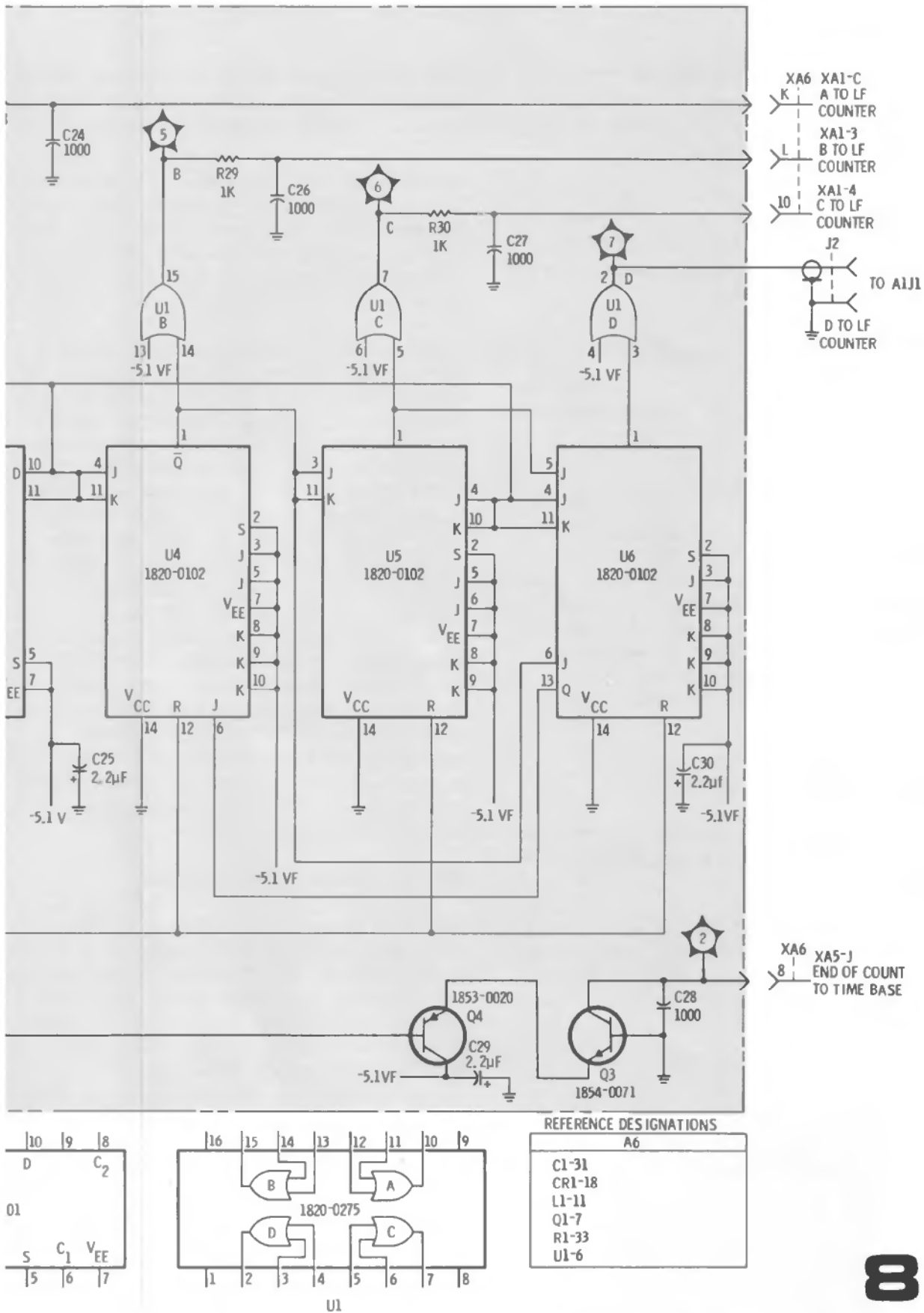

Figure 8-37. High Frequency Decade Assembly, Schematic Diagram

SERVICE SHEET 9

Normally causes of malfunctions in the model 8443A circuits will be isolated to a circuit board or assembly as a result of performing the tests specified in the Troubleshooting Tree.

When trouble has been isolated to the low frequency counter assembly (A1), it should be removed from the chassis and reinstalled using an extender board. This will provide easy access to test points and components.

Equipment Required

4 Channel Oscilloscope
10:1 Oscilloscope
Probes (4)

Service Kit
Digital Voltmeter

1 DS1 Drive Circuit

The least significant digit is displayed on DS1. When the transfer pulse from the time base is applied to buffer/store U8, the information in the high frequency decade is transferred to decoder/driver U1. U1 decodes the 1-2-4-8 information to cause the appropriate number in the numerical readout to be illuminated. U8 also provides a BCD output to a rear panel connector for use in external equipment.

Test Procedure 1

Test 1-a. Use the digital voltmeter to verify the presence of dc levels at pins A and B/2 shown on the schematic diagram.

Test 1-b. If the A, B, C and D inputs are as shown in Waveform SS9-1, and none of the numerical readouts illuminate, trouble is probably in the +175 volt or +5 volt circuits. Check for an open circuit in L1, L2 or L3.

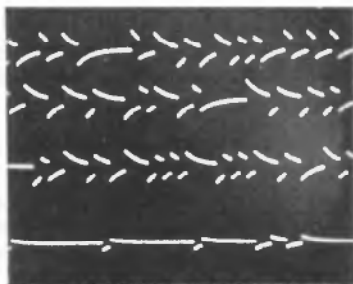

Waveform SS9-1

Test 1-c. If some, or all of the other numerical readouts illuminate, trouble is probably in DS1, U1 or U8. Isolate the cause of trouble as follows:

Ground (one at a time) pins 1, 2, 3, 4, 11, 12, 13, 14, 15 and 16 of U1. Refer to the schematic and verify that the proper number illuminates for each pin as they are grounded. If none of the numbers illuminate, check R1. If R1 is providing power to DS1, DS1 is defective.

If DS1 numbers illuminate as they should in the previous test, connect the oscilloscope to U8 as follows: Channel A — pin 14, Channel B — pin 1, Channel C — pin 3 and Channel D — pin 16. Set the oscilloscope TIME/DIV to .5 second and the Volts/Div to .5. Operate the model 8443A in the MARKER mode at 10 Hz resolution. Place the analyzer SCAN WIDTH PER DIVISION to 10 MHz, SCAN WIDTH to PER DIVISION and SCAN TIME PER DIVISION to 1 MILLISECOND. At these analyzer settings, the least significant digit of the counter will change numbers quite rapidly; as a result, the output from the buffer store will also change rapidly. The oscilloscope display should appear (to the eye) as four dots moving from left to right and changing in amplitude erratically. A time exposure of the oscilloscope CRT should be similar to that shown in waveform SS9-1. If the oscilloscope display is correct, U1 is defective. If the display is not correct, U8 is defective.

2 DS2 through DS7 Drive Circuits

The six counter circuits following that of the least significant digit each consist of a blanking decade counter, a buffer/store, a decoder/driver and a numerical readout device. DS3, DS4 and DS5 have inputs that will cause a decimal point to illuminate in one of them; the position of the RESOLUTION switch determines which decimal point is illuminated. Blanking inputs are provided to the circuits driving DS4, DS5, DS6 and DS7.

Each of the last five blanking decade counters is driven by the divide-by-ten output of the blanking decade counter which precedes it. The first blanking decade counter (U16) is driven by the \bar{D} output of the high frequency decade. When the transfer pulse is received, each buffer/store transfers the count information from the blanking decade counter to the decoder/driver and to a BCD output connector on the rear panel. The

decoder/drivers operate on negative logic; the rear panel BCD outputs are positive logic. When the reset pulse appears all of the blanking decade counters and the high frequency decade are set to zero.

Test Procedure 2

General

The numerical readout indicators, in many instances, will help to localize a problem to a specific area within the low frequency counter circuits.

If any one of the numerical readouts does not function, but numerical readouts to the left of it do, the trouble is likely to be the readout itself, the decoder/driver, or the buffer/store associated with that readout. It is not likely that the associated blanking decade counter is defective.

If any numerical readout is blank or reads only one number and the readouts to the left consistently read 0, the blanking decade counter for the first readout affected (from the right) is probably defective.

Test 2-a. If a single numerical readout is not functioning, ground (one at a time) pins 1, 2, 3, 4, 11, 12, 13, 14, 15 and 16 of the decoder/driver which drives it. Refer to the schematic diagram to verify that the right number is illuminating.

If none of the numbers illuminate, check the 6800 ohm resistor associated with that readout. If the 6800 ohm resistor is supplying power, the readout device is defective.

If the readout device illuminates correctly when the specified pins are grounded, proceed to test 2-b.

Test 2-b. Connect the oscilloscope to the buffer/store associated with the malfunctioning readout as follows: Channel A — pin 14, Channel B — pin 1, Channel C — pin 3 and Channel D — pin 16. Set the oscilloscope TIME/DIV to 1 second and the VOLTS/DIV to .5. Operate the model 8443A in the EXTERNAL mode at 10 Hz resolution with the RF OUTPUT connected to the COUNTER INPUT. Set the analyzer SCAN WIDTH PER DIVISION to 10 MHz, the SCAN WIDTH to PER

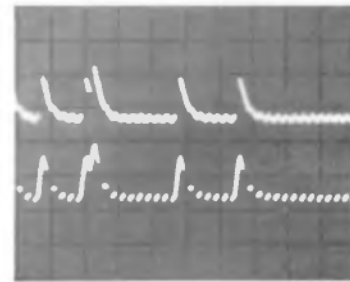

Waveform SS9-2

DIVISION and the SCAN TIME PER DIVISION to 1 second. The oscilloscope CRT display should appear (to the eye) as four dots moving from left to right and changing erratically in amplitude. A time exposure of the oscilloscope CRT should be similar to waveform SS9-1. If the oscilloscope CRT display is as shown, the decoder/driver is defective. If the display is not correct, proceed to test 2-c.

Test 2-c. Connect the oscilloscope to the blanking decade counter associated with the malfunctioning readout as follows: Channel A — pin 15, Channel B — pin 1, Channel C — pin 2 and Channel D — pin 16. With all equipment operating as it was in test 2-b, the oscilloscope CRT should again show four dots moving from left to right and varying erratically in amplitude. If the signal is present, but was not in test 2-b, the buffer/store is defective. If the signal is not present, connect one channel of the oscilloscope to pin 9 of the blanking decade counter. All controls remain the same except that the oscilloscope CRT trace is centered and VOLTS/DIV is set to .2. The oscilloscope CRT presentation should be similar to that shown in Waveform SS9-2. If this waveform is present and the previous one was not, the blanking decade counter is probably defective. If the signal is not present, the preceding blanking decade counter is defective.

2 DS8 Drive Circuit

The most significant digit, displayed by DS8 in the 10 Hz resolution mode, is used only when the input frequency to the high frequency decade is 100 MHz or higher. Below 100 MHz, DS8 is blanked because there is no positive-going output from U21. The output of U21 changes state on a count of 8 (representative of 80 MHz), but since

this transition is negative-going, it has no effect on U15A. When U21 receives a tenth input pulse (representative of 100 MHz), it again changes state and the positive-going transition clocks U15A. The Q output of U15A goes high and is applied to the D input of U15B, which acts as a buffer/store. When the transfer pulse appears and the D input to U15B is high, U15B is clocked and the Q output is used to turn on Q1. When Q1 conducts it completes the circuit for the numeral 1 in DS8. The \bar{Q} output of U15B is inverted by Q2 and applied as a BCD bit to the rear panel BCD connector.

Test Procedure 3

Test 3-a. Connect the oscilloscope to U15 as follows: Channel A — pin 11, Channel B — pin 9, Channel C — pin 5 and Channel D — pin 6. Set the oscilloscope SWEEP MODE to NORM, INTERNAL Sync, 5 mSec/Div, .5 VOLTS/DIV and DC inputs. Set the model 8443A to operate in the SCAN HOLD mode, MARKER POSITION knob pulled out, 10 Hz resolution. Operate the analyzer in the ZERO scan mode at 95 MHz. The oscilloscope CRT display should be as shown in waveform SS9-3.

Change the analyzer FREQUENCY to 105 MHz. Note that U15A Channel B Q output (pin 9) goes high when the frequency reaches 100 MHz. The Q output of U15B (Channel C), goes high and the \bar{Q} output of U15B (Channel D) goes low. The oscilloscope CRT display should now be as shown in Waveform SS9-4.

In the above tests, if the Channel A and B waveforms were correct and the Channel C and/or D were not, proceed to test 3-b. If all waveforms were correct and the numeral 1 did not light in

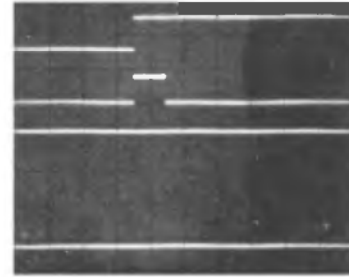

Waveform SS9-4

DS8 when the frequency was over 100 MHz, proceed to test 3-c. If the Channel A waveform was correct, but channel B was not, U15 is defective.

Test 3-b. Leave Channel A and B of the oscilloscope connected as they were in the above tests. Connect the Channel C input to U15 pin 13 and the Channel D input to U15 pin 3. The oscilloscope CRT display should be as shown in waveform SS9-5. If either the transfer or reset pulses are missing and the other counter digits function properly, U22 is defective.

Test 3-c. Apply a ground to Q1-c. If DS8 numeral 1 illuminates, Q1 is defective. If it does not, DS8 is defective.

4 Blanking

When the UNBLANKED-BLANKED switch on the rear panel is in the BLANKED position, all zeros which are to the left of the decimal point and also to the left of the first significant digit are blanked.

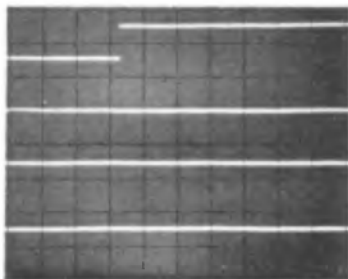

Waveform SS9-3

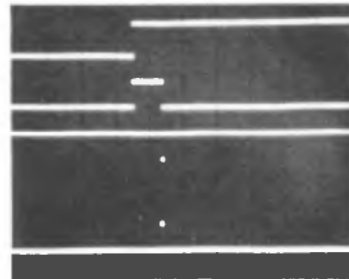

Waveform SS9-5

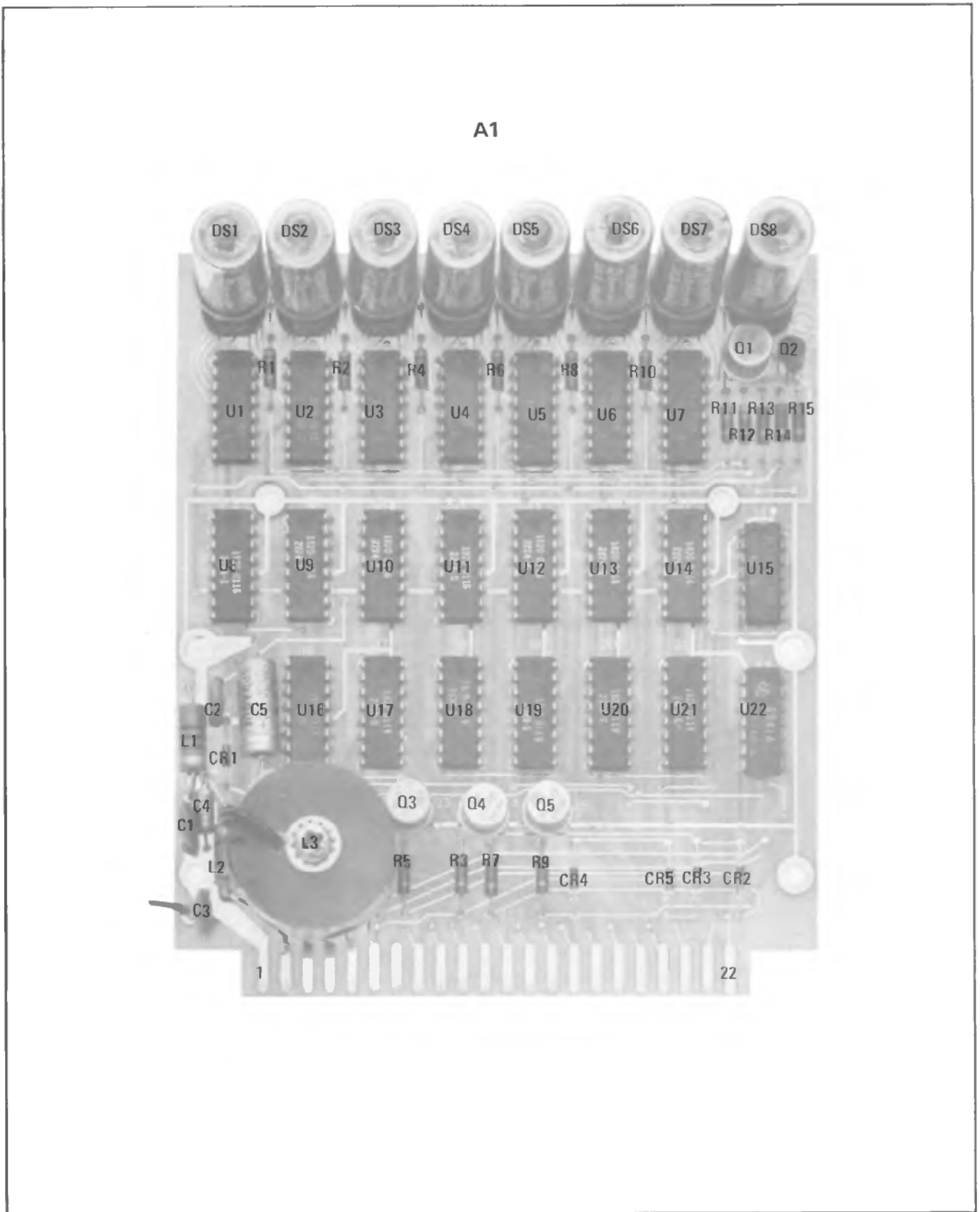
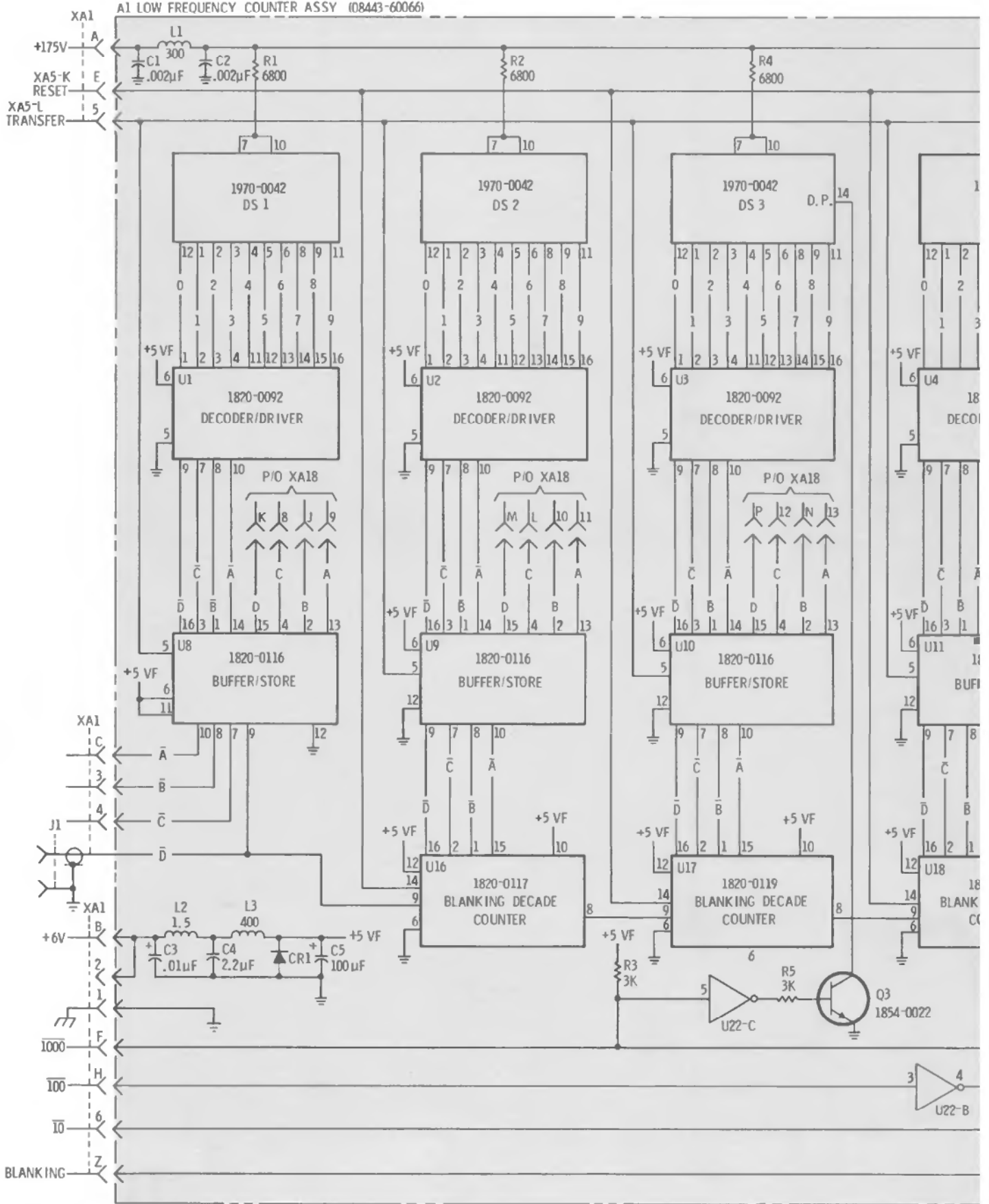
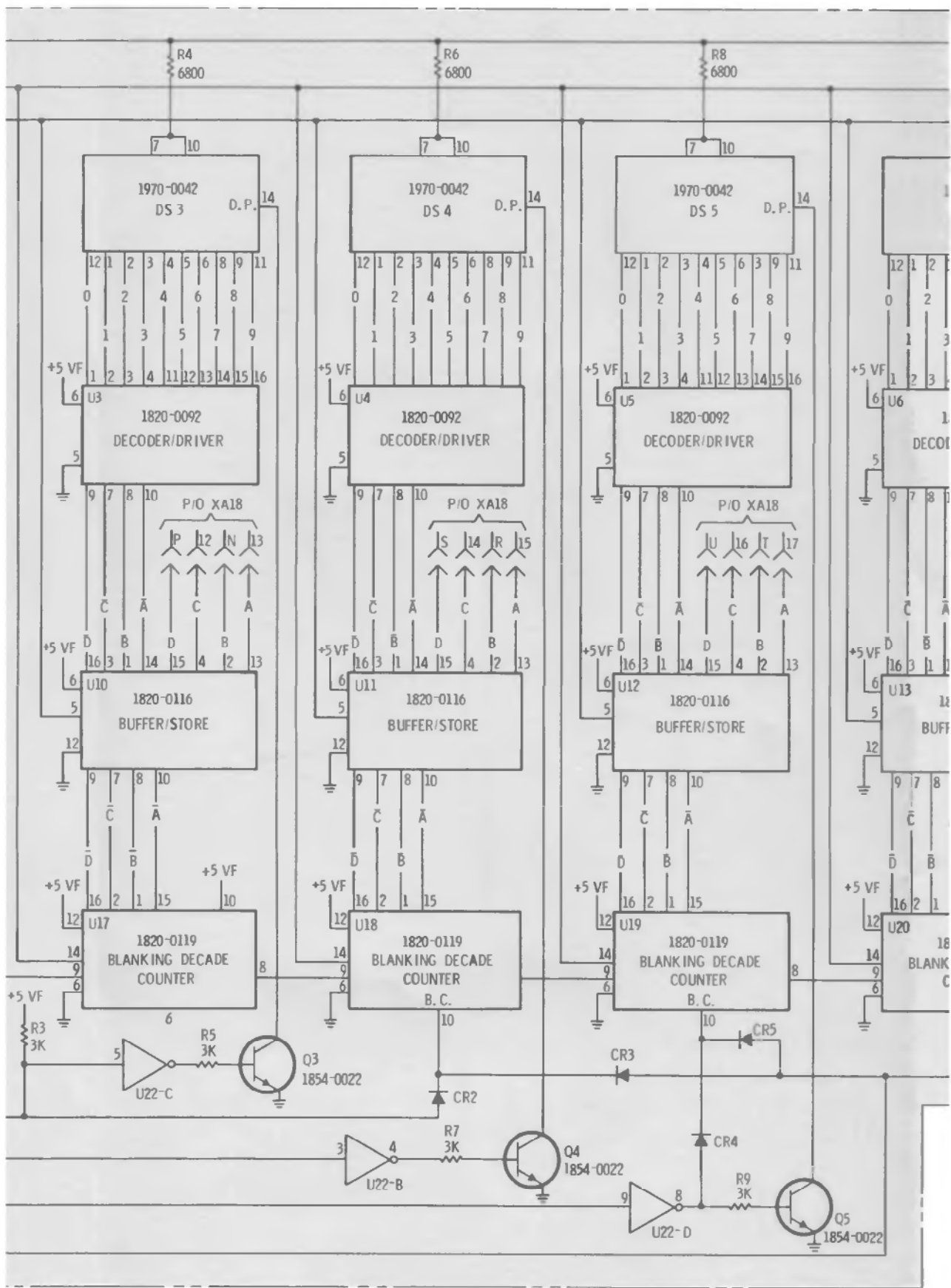

Figure 8-38. A1, Low Frequency Counter Assembly, Components

A1 LOW FREQUENCY COUNTER ASSY (08443-60066)





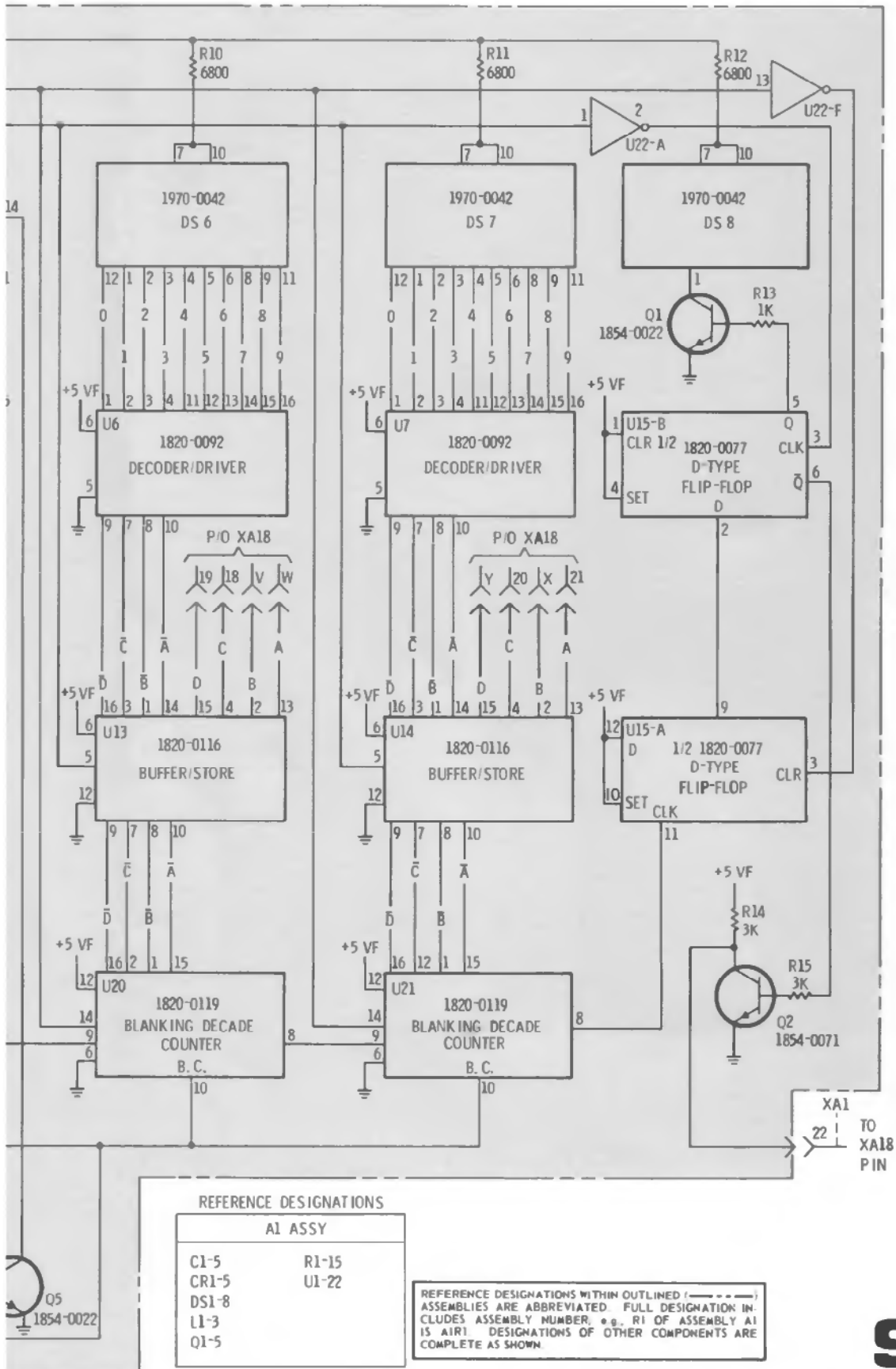

Figure 8-39. Low Frequency Counter Circuit Schematic Diagram

9

Section VIII
Service

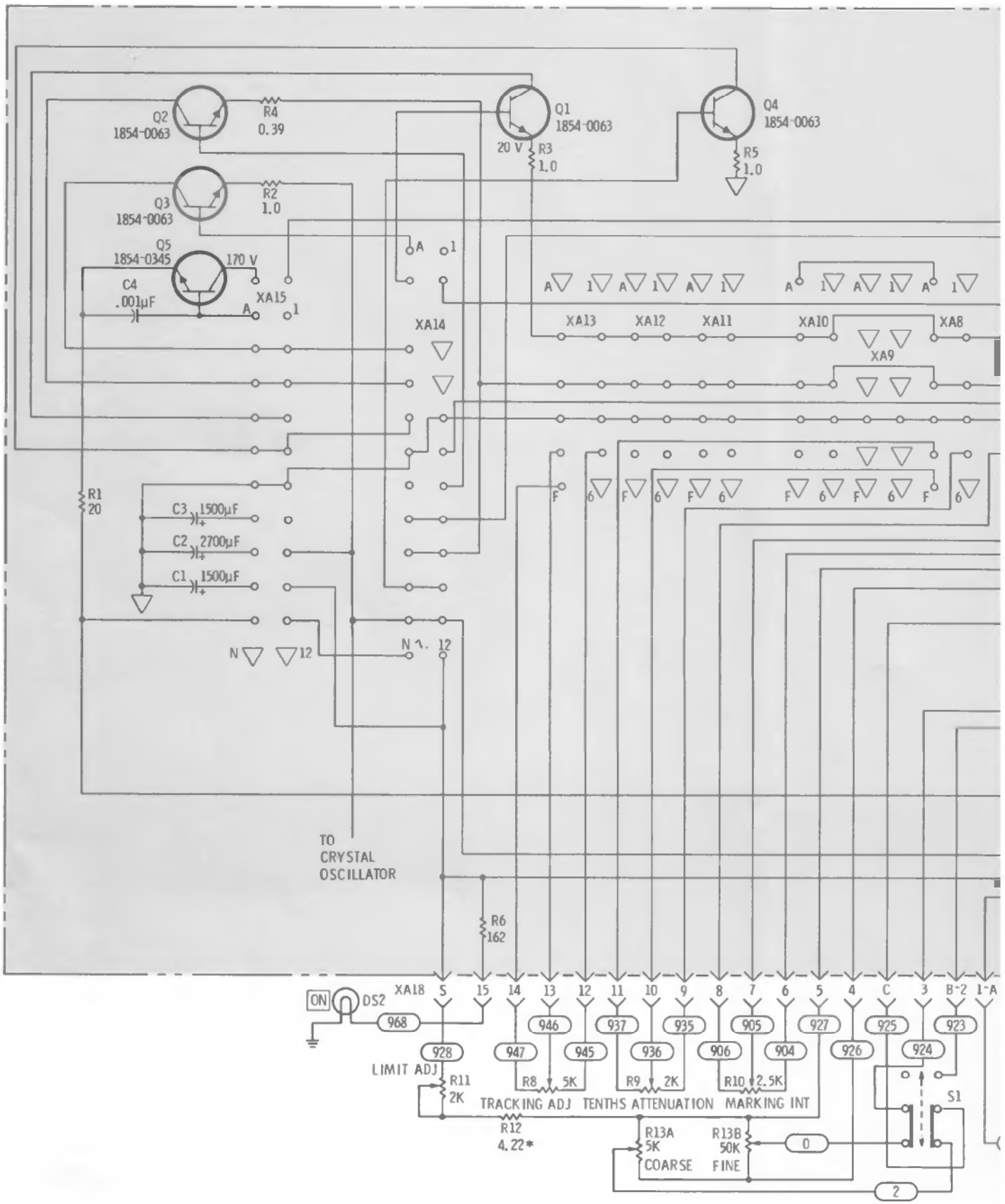
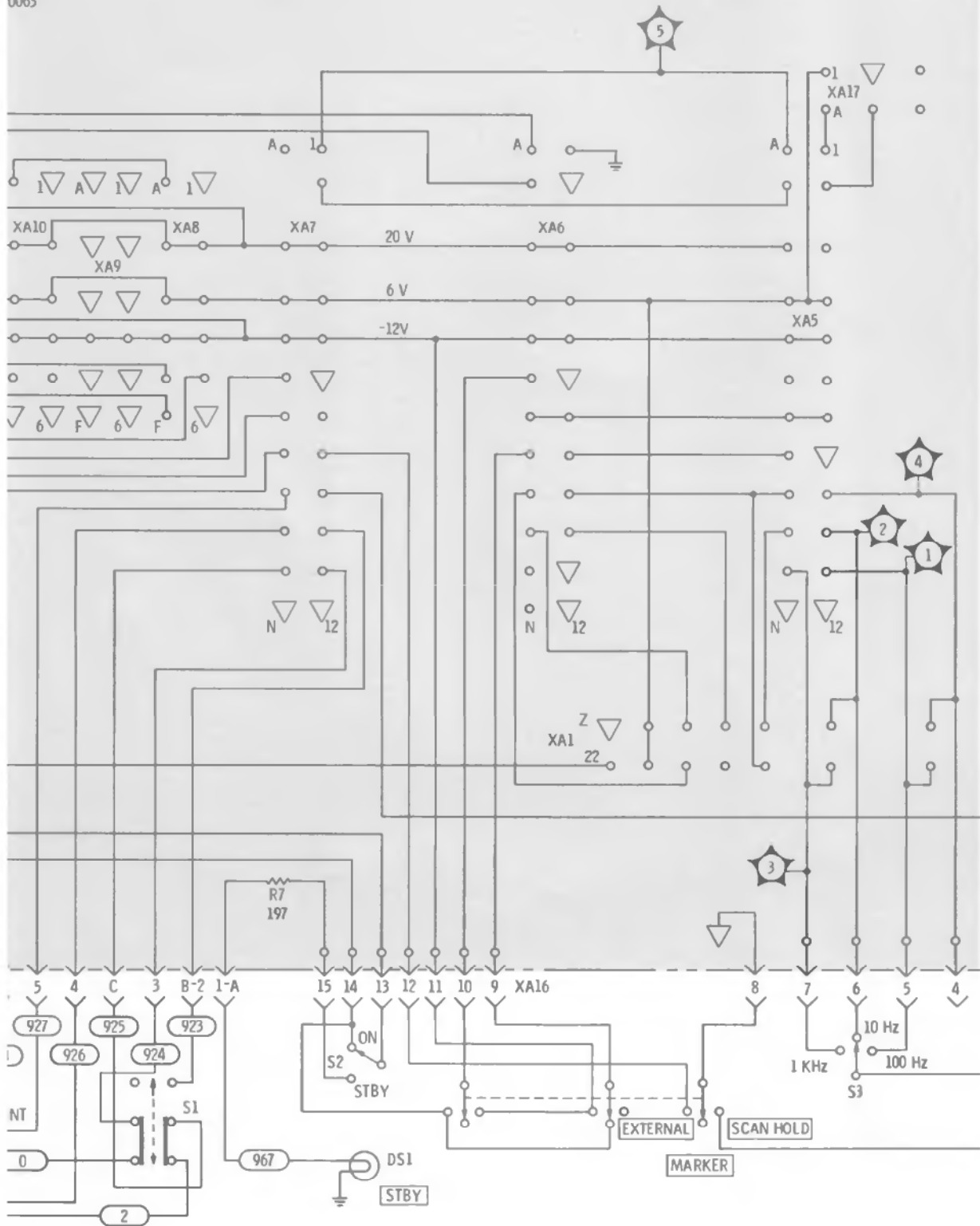
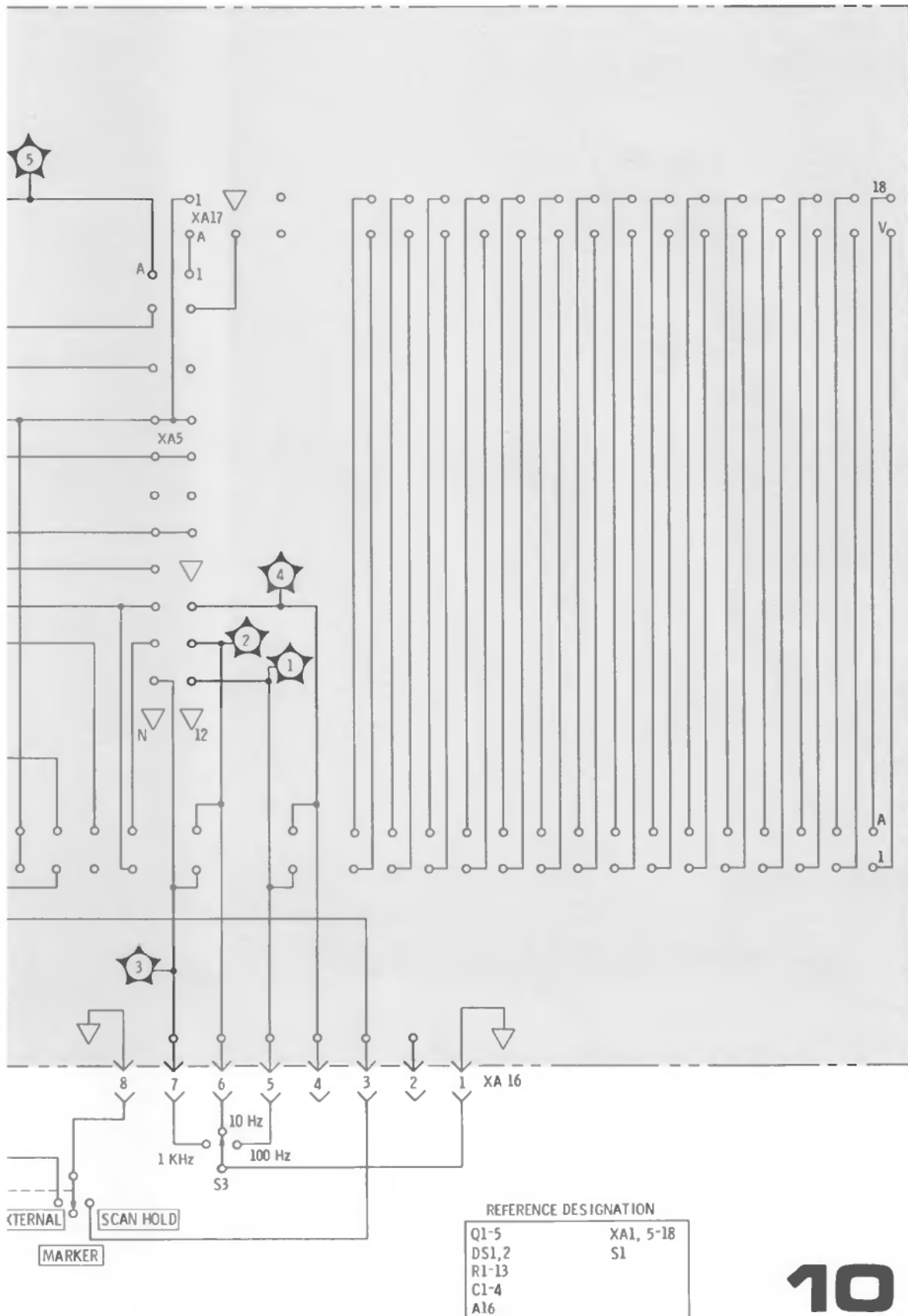

Figure 8-40. Overall Wiring Diagram, Including Chassis Mounted Parts

0063





10

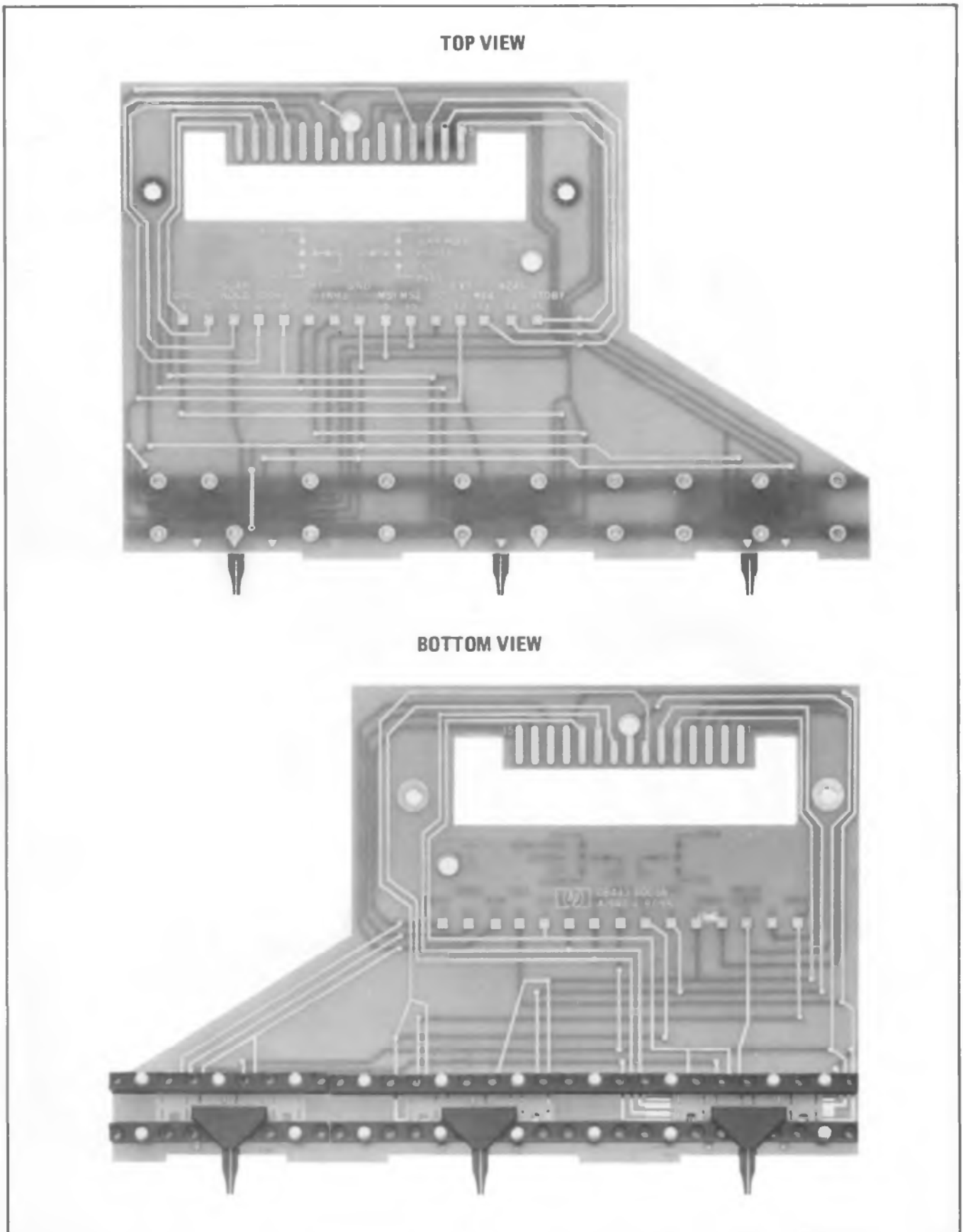

Figure 8-41. A16, Switch Assembly

